



Büro für Tragwerksplanung und Ingenieurbau  
vom Felde + Keppler GmbH & Co. KG

Lütticher Straße 10-12  
52064 Aachen  
www.vom-felde.de

Telefon: 0241 / 70 96 96  
Telefax: 0241 / 70 96 46  
buero@vom-felde.de

## Structural Report

F43P

17334

for the system by

**Global Truss**  
Furong Industrial Area  
Shajing Town

Baoan District Shenzhen China

compiled by:

*A. Rempel*

Aachen, 27.06.2017



This Structural Report includes pages

1 - 30

This Structural Report is set up exclusively for the company Global Truss.  
Forwarding to third parties only with the author's approval.



## TABLE OF CONTENTS

1 PRELIMINARY NOTES .....	1
1.1 Basics .....	1
1.2 Materials .....	1
1.3 General remarks .....	1
1.4 Geometry and loadings .....	2
2 SYSTEM .....	5
3 SECTION- AND MATERIAL PORPERTIES .....	6
4 ALLOWABLE LOADING SINGLE COMPONENTS .....	9
5 ALLOWABLE LOADING SINGLE SPAN GIRDER .....	15
5.1 Vertically uniformly distributed loads (UDL).....	15
5.2 Single point load in 1/2 point.....	17
5.3 Single point load in 1/3 points.....	20
5.4 Single point load in 1/4 points.....	23
5.5 ESingle point load in 1/5 points.....	26
6 SUMMARS OF RESULTS .....	29
6.1 Allowable loading: .....	29
6.2 Deflection at allowable loading: .....	30

## ANNEXES .....

Drawings F43P. ....

F43050P-Model, F43100P-Model, F43150P-Model, F43200P-Model,  
F43250P-Model, F43300P-Model, F43350P-Model, F43400P-Model,  
F43450P-Model, F43500P-Model



# 1 PRELIMINARY NOTES

## 1.1 Basics

The currently applicable regulations and standards, in particular:

DIN EN 1991-1	Actions on structures (Eurocode 1)
DIN EN 13814	Fairground and amusement park machinery and structures
DIN EN 13782	Temporary Structures – Tents
DIN EN 1993-1	Design of steel structures (Eurocode 3)
DIN EN 1999-1	Design of aluminium structures (Eurocode 9)

## 1.2 Materials

Tubes	Aluminium EN AW-6082 T6
Bolts	grade min. 8.8

## 1.3 General Remarks

This structural report is a structural calculation concerning a truss system produced by the company GLOBAL TRUSS. The truss type goes by the name F43P. The structural report is the basis for the certification by TÜV based on EN 1999-1.

The truss system is part of a "modular construction system" with the different truss lengths

500mm, 1000mm, 1500mm, 2000mm, 2500mm, 3000mm, 3500mm, 4000mm, 4500mm and 5000mm.

The Trusses consist of one upper and two lower main chords (round tube 50 x 3mm), which are arranged in a triangular shape. The trusses also consist of welded diagonal bracings (round tube 25 x 3mm). The truss type F43P is stiffened by diagonal bracings at all three sides.

The distance between the system lines of the mainchords is 35 cm.

The trusses are connected with couplers consisting of female fittings, connectors and bolts.

The allowable loads are listed in tables (see chapter 6).

The verification of the single parts is done according the safety concept of EN 1990 with a partial safety factor on the loading side of 1.50 for payloads.

For applications which can be calculated on the basis of other codes, the partial safety factors can be adjusted (for example temporary structures acc. EN 13814,  $\gamma_F = 1.35$  for payloads).

To use the resulting allowable loads with British Standard (BS) and ANSI, the allowable loads listed in tables have to be multiplied by 0.85.



## 1.4 Geometry and Loadings

the following loadcases are taken into account

uniformly distributed load (UDL)

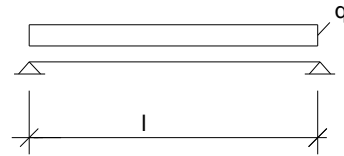

Single-load in 1/2 point

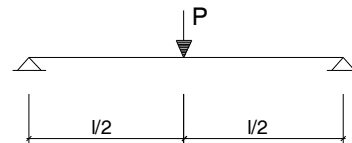

Single-load in 1/3 points

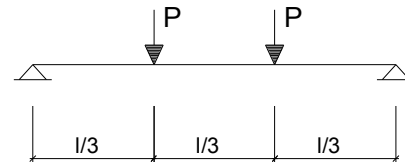

Single-load in 1/4 points

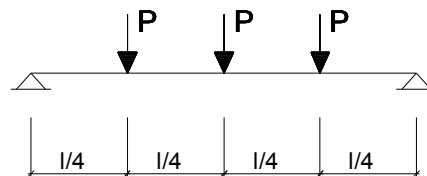

Single-load in 1/5 points

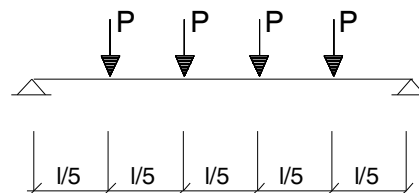

The selfweight of the truss is approx. 7.5 kg/m.



For the application of the calculated allowable loadings the following rules have to be regarded:

Large loads have to be applied at the nodes or have to be distributed by appropriate constructions.

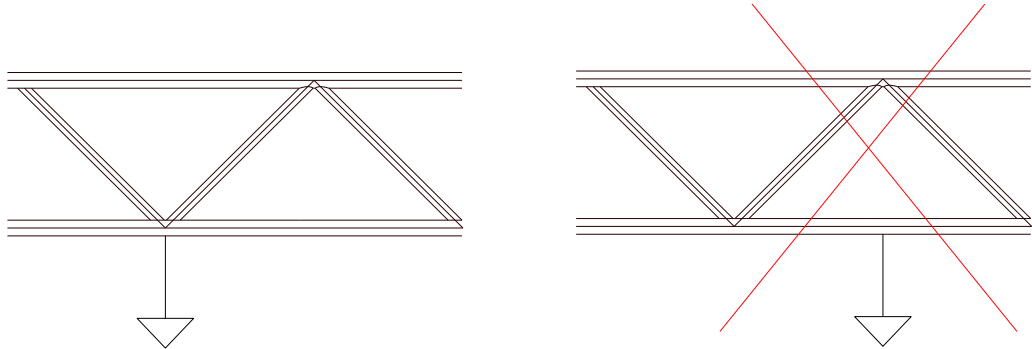

Loads at the middle of the couplers are not allowed.

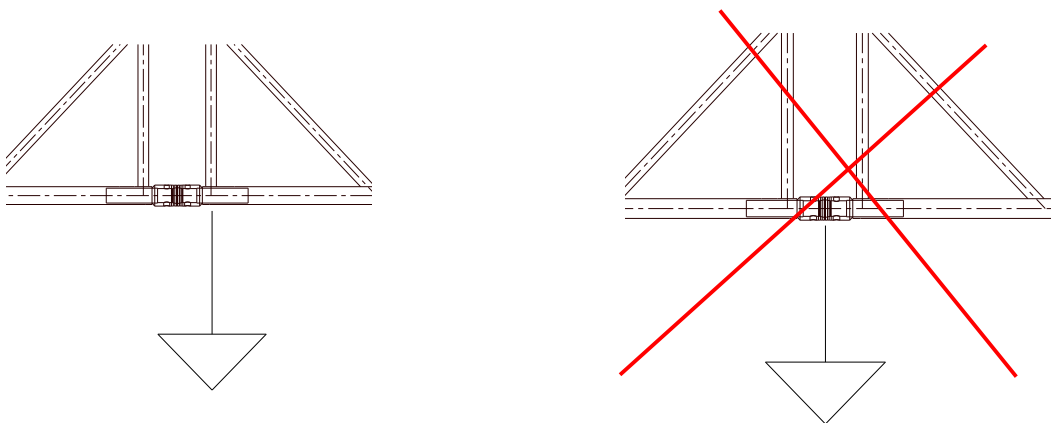

All loads have to be distributed equally to the chords.

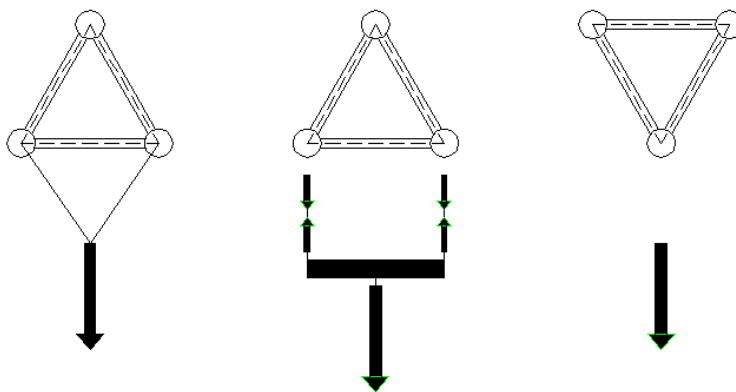



For the support or suspension there are the following possibilities:

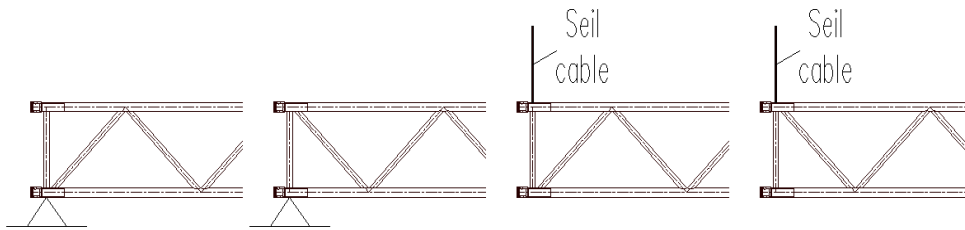

When restricting the position of the coupler (see chapter 4, case 2), the coupler has to be located  $> 1,0$  m from the loading point into the direction of the support.

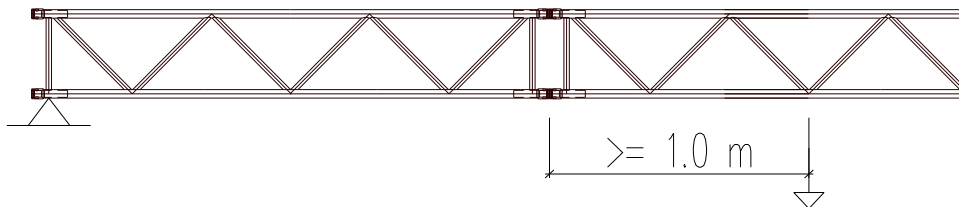



## 2 SYSTEM

Drawings F43P .....

F43050P-Model, F43100P-Model, F43150P-Model, F43200P-Model,  
F43250P-Model, F43300P-Model, F43350P-Model, F43400P-Model,  
F43450P-Model, F43500P-Model

see annex



### 3 SECTION- AND MATERIAL PROPERTIES

<b>Properties Tubes</b>						
	D	t	A	I	Wel	i
	[mm]	[mm]	[cm <sup>2</sup> ]	[cm <sup>4</sup> ]	[cm <sup>3</sup> ]	[cm]
main chords	50,0	3	4,43	12,28	4,91	1,67
vertical Bracing	25	3	2,07	1,28	1,02	0,79
horizontal Bracing	25	3	2,07	1,28	1,02	0,79

**Truss geometry**

distance axes main chords	vertical	ev	30,3	[cm]
	horizontal	eh	35	[cm]
min. gradient bracing	vertical	$\alpha$	34,5	[°]
	horizontal	$\alpha$	34,5	[°]

**Properties truss-Section**

$A$	$= 3 \times A_G$	=	13,29	[cm <sup>2</sup> ]
$I_{yy}$	$= 3 \times I_G + A_G \times [2 \times (ev/3)^2 + (ev \times 2/3)^2]$	=	2748,05	[cm <sup>4</sup> ]
$I_{zz}$	$= 3 \times I_G + 2 \times A_G \times (eh/2)^2$	=	2750,00	[cm <sup>4</sup> ]
$I_t$	approximately	=	350,00	[cm <sup>4</sup> ]
$i_y$	$= (I_{yy}/A)^{1/2}$	=	14,38	[cm]
$i_z$	$= (I_{zz}/A)^{1/2}$	=	14,39	[cm]

Index G : section properties main chord





Material properties

<b>Chords and bracing</b>	EN AW 6082 T6 (AlMgSi1)	
allowable stress acc. to EN-1999-1-1		
partial safety factors material		
YM1=	1,10	buckling class / BC= A
YM2=	1,25	
0,2%-Proof Strength	ultimate tensile strength	
fo t≤5mm=	250 [N/mm²]	fu t≤5mm= 290 [N/mm²]
fo t>5mm=	260 [N/mm²]	fu t>5mm= 310 [N/mm²]
fo,haz=	125 [N/mm²]	fu,haz= 185 [N/mm²]
Strength of welding seams	fw= 190 [N/mm²]	
Factor for HAZ-values for TIG-welding:	0,8	

<b>Bolt</b>	min. grade 8.8
-------------	----------------

<b>Connector</b>	EN AW 2011 (AlCuBiPb F37)		
0,2%-Proof Strength	ultimate tensile strength		
fo>	230 [N/mm²]	fu>	310 [N/mm²]

<b>Female fitting</b>	EN AW 6082 T6		
allowable stress acc. to EN-1999-1-1			
partial safety factors material			
YM1=	1,10		
YM2=	1,25		
0,2%-Proof Strength	ultimate tensile strength		
fo=	250 [N/mm²]	fu=	290 [N/mm²]

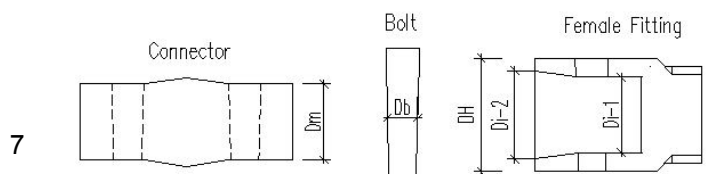



Section- and material properties of the chord tubes					
Material	E=	70000	[N/mm <sup>2</sup> ]		
	f <sub>o</sub> =	250,00	[N/mm <sup>2</sup> ]		
	f <sub>o</sub> /Y <sub>M1</sub> =	227,27	[N/mm <sup>2</sup> ]		
	f <sub>o,haz</sub> =	125,00	[N/mm <sup>2</sup> ]		
	f <sub>u</sub> =	290,00	[N/mm <sup>2</sup> ]		
	f <sub>u</sub> /Y <sub>M2</sub> =	232,00	[N/mm <sup>2</sup> ]		
	f <sub>u,haz</sub> =	185,00	[N/mm <sup>2</sup> ]		
	f <sub>u,haz</sub> /Y <sub>M2</sub> =	148,00	[N/mm <sup>2</sup> ]		
cross section	D <sub>0</sub> =	50,00	[mm]		
	A=	4,43	[cm <sup>2</sup> ]		
	I=	12,28	[cm <sup>4</sup> ]		
	i=	1,67	[cm]		
Determination of section-class	β=	12,25	[-]	3 · (D <sub>0</sub> / t) <sup>0,5</sup> nach 6.10	
	ε=	1,00	[-]	(250 / f <sub>o</sub> ) <sup>0,5</sup>	
	QS-Klasse=	2		acc. chapter 6.1.4.4	
Coefficients for buckling	BC=	A	[-]		
	α=	0,20	[-]		
	λ <sub>0</sub> =	0,10	[-]		
teff in heat affected zone	red-Faktor=	0,8	[-]	(WIG π <sub>IG</sub> )	
	node with 1 bracing				
	D <sub>1</sub> =	25,00	[mm]		
	U <sub>WEZ</sub> =	85,00	[mm]	D <sub>1</sub> + 2 · 30	
	U <sub>Total</sub> =	157,08	[mm]		
	teff,o/t=	0,68	[-]	[1 - (1 - red-Faktor · f <sub>o,haz</sub> / f <sub>o</sub> ) · U <sub>WEZ</sub> / U <sub>Total</sub> ]	
	teff,u/t=	0,74	[-]	[1 - (1 - red-Faktor · f <sub>u,haz</sub> / f <sub>u</sub> ) · U <sub>WEZ</sub> / U <sub>Total</sub> ]	
	node with 2 bracing				
	D <sub>1</sub> =	25,00	[mm]		
	D <sub>2</sub> =	25,00	[mm]		
	U <sub>WEZ</sub> =	111,18	[mm]	π / 6 · D <sub>0</sub> + D <sub>1</sub> / 2 + D <sub>2</sub> / 2 + 2 · 30	
	U <sub>Total</sub> =	157,08	[mm]		
	teff,o / t=	0,58	[-]	[1 - (1 - red-Faktor · f <sub>o,haz</sub> / f <sub>o</sub> ) · U <sub>WEZ</sub> / U <sub>Total</sub> ]	
	teff,u / t=	0,65	[-]	[1 - (1 - red-Faktor · f <sub>u,haz</sub> / f <sub>u</sub> ) · U <sub>WEZ</sub> / U <sub>Total</sub> ]	

Section- and material properties of the bracing				
Material	E=	70000	[N/mm <sup>2</sup> ]	
	f <sub>o</sub> =	250,00	[N/mm <sup>2</sup> ]	
	f <sub>o</sub> /Y <sub>M1</sub> =	227,27	[N/mm <sup>2</sup> ]	
	BC=	A	[-]	
	α=	0,20	[-]	
	λ <sub>0</sub> =	0,1	[-]	
	cross section	D <sub>0</sub> =	25	[mm]
A=		2,07	[cm <sup>2</sup> ]	
I=		1,28	[cm <sup>4</sup> ]	
i=		0,79	[cm]	



## 4 ALLOWABLE LOADING SINGLE COMPONENTS

main chord in heat affected zone at coupler			
$NR_d = A \times 0,8^* \times f_{u,haz} / Y_{M2} =$	<b>52,45</b>	[kN]	*(WIG TIG) local welding seam acc. chapter 6.2.9.3 (1)
main chord in heat affected zone			
node with 1 bracing			
$NR_d = A_{eff} \times f_o / Y_{M1} =$ (mit $A_{eff} = t_{eff,o} / t \times A$ )	<b>67,99</b>	[kN]	local welding seam acc. Chapter 6.2.9.3 (2)
node with 2 bracing			
$NR_d = A_{eff} \times f_o / Y_{M1} =$ (mit $A_{eff} = t_{eff,o} / t \times A$ )	<b>57,92</b>	[kN]	local welding seam acc. Chapter 6.2.9.3 (2)
buckling main chord between nodes with 1 bracing in the middle			
sk=	<b>84,00</b>	[cm]	
Ncr=	120,25	[kN]	
$\lambda^* =$	0,79	[-]	
$\phi =$	0,88	[-]	
X=	0,79	[-]	
$\kappa =$	1,00	[-]	verified by comparative calculation acc. Second Order Theory acc. equation 6.49a
$NR_d = X \times \kappa \times A_{eff} \times f_o / Y_{M1} =$	<b>53,54</b>	[kN]	
buckling main chord between nodes without bracing in the middle			
sk=	<b>84,00</b>	[cm]	
Ncr=	120,25	[kN]	
$\lambda^* =$	0,96	[-]	
$\phi =$	1,05	[-]	
X=	0,68	[-]	
$NR_d = X \times A \times f_o / Y_{M1} =$	<b>68,78</b>	[kN]	acc. equation 6.49a
welding seam between chord and female conical coupler			
f <sub>w</sub> =	190,00	[N/mm <sup>2</sup> ]	
Y <sub>mw</sub> =	1,25	[-]	
$NR_d = A \times f_w / Y_{M1} =$	<b>67,33</b>	[kN]	acc. equation 8.29

relevant for main chord tubes:

**NR<sub>dG</sub> = 52,45 kN**



bracing in heat affected zone			
$NR_d = A \times 0,8^* \times f_{u,haz} / Y_{M2} =$	<b>24,55</b>	[kN]	*(WIG TIG) local welding seam acc. chapter 6.2.9.3 (1)
buckling bracing			
sk=	47,00	[cm]	(buckling length = 0,75 x l)
Ncr=	39,96	[kN]	
$\lambda^* =$	1,14	[-]	
$\phi =$	1,25	[-]	
X=	0,56	[-]	
$NR_d = X \times A_G \times f_o / Y_{M1} =$	<b>26,57</b>	[kN]	acc. equation 6.49a
welding seam between chord and female conical coupler			
f <sub>w</sub> =	190,00	[N/mm <sup>2</sup> ]	
Y <sub>mw</sub> =	1,25	[-]	
$NR_d = A \times f_w / Y_{M1} =$	<b>31,52</b>	[kN]	acc. equation 8.29

relevant for bracing tubes: **NR<sub>d</sub> = 24,55 kN**



### Allowable normal force at coupler:

<b>Bolt</b>		
material (8.8)	fy,bk=	64,00 [kN/cm <sup>2</sup> ]
	fu,bk=	80,00 [kN/cm <sup>2</sup> ]
geometry	Db=	1,08 [cm]
	Ab=	0,91 [cm <sup>2</sup> ]
allowable loading due to shearing acc. to EN 1999-1-1		
NRd = 2 x 0,60 x Ab x fu,bk / 1,25=		<b>69,71 [kN]</b>
<b>Connector</b>		
material	EN AW 2011 (AlCuBiPb F37)	
geometry	Dm=	29 [mm]
<u>Bearing stress in connector</u>	fu / YM2=	248,00 [N/mm <sup>2</sup> ]
	do=	11 [mm]
	t=	29 [mm]
	e1=	17,1 [mm]
	αb=	0,52 [-]
	e2=	14,5 [mm]
	k1=	1,99 [-]
NRd = k1 x αb x fu x d x t / YM2=		81,62 [kN]
<u>Remaining section under tension</u>		
NRd = 0,9 x A <sub>net</sub> x fu / YM2=		<b>76,23 [kN]</b>
<b>Female Fitting</b>		
geometry	DH=	50 [mm]
	Di-1=	29 [mm]
	Di-2=	35 [mm]
	Di-m=	32 [mm]
<u>Bearing stress in female fitting</u>	fu / YM2=	232 [N/mm <sup>2</sup> ]
	do=	13 [mm]
	t = DH - Di-m=	18 [mm]
	e1>	23 [mm]
	αb=	0,59
	e2>	20 [mm]
	k1=	2,5
NRd = k1 x αb x fu x d x t / YM2=		<b>80,04 [kN]</b>

The allowable normal force of the coupler is not relevant compared to the allowable normal force of the tube.  
(NRd<sub>G</sub> = 52,45 kN < 69,71 kN).



### Interaction bending and normal force at coupler

Normal force and bending moments are transferred by the welding seam between coupler and chord.

Verification of interaction bending and normal force at coupler

$$\Rightarrow (N_{sdG} / NR_{dG})^{1,3} + (M_{sdG} / MR_{dG}) < 1,0$$

mit  $N_{sdG} = N_{sd} / 3 + M_{sd} / (0,303 \text{ m})$

und  $M_{sdG} = 1 / 3 \cdot Q_{sd} \cdot 6,75 \text{ cm} = 2,25 \text{ cm} \cdot Q_{sd}$

$\Rightarrow a = \text{factor for cantilever at the coupler} = 2,25 \text{ cm}$

$N_{sd}$ ,  $M_{sd}$  und  $Q_{sd}$ : global internal forces in the truss (in kN resp. kNm)

The global internal forces include the following safety factors acc. Eurocode:

selfweight of the truss:  $y_F = 1,35$

Net load on the truss:  $y_F = 1,50$

$NR_{dG} = \text{allowable loading of the chord in the heat affected zone (see following table):}$

main chord in heat affected zone at coupler			
$NR_{dG} = A \times 0,8^* \times f_{u,haz} / \gamma_{M2} =$	<b>52,45</b>	[kN]	*(WIG $\pi_{IG}$ ) local welding seam acc. chapter 6.2.9.3 (1)

$MR_{dG} = \mu_{uRd}$  (see following table):

Local bending of chord completely in HAZ			
local welding seam acc. Chapter 6.2.9.3 (1)			
D=	50	[mm]	
red-Faktor=	0,8	[-]	(WIG $\pi_{IG}$ )
$\rho_{u,haz} =$	0,64	[-]	$f_{u,haz} / f_u$
$t_{u,eff} =$	1,53	[mm]	red-Faktor $\cdot \rho_{u,haz} \cdot t$
$W_{u,eff} = \pi \times R^2 \times t_{u,eff} =$	2,66	[cm <sup>3</sup> ]	with $R = D / 2 - t / 2$
$\mu_{uRd} = W_{u,eff} \cdot f_u / \gamma_{M2} =$	<b>61,63</b>	[kNcm]	acc. equation 6.24b



The following 3 cases are taken into account.

### 1. Loading with **uniformly distributed load (UDL)**

The coupler is always located at the theoretically worst point. This results from the following extremum-calculation:

Note: For the determination of the worst position of the coupler, the exponent 1,3 for the relation of actual load to the allowable load is not taken into account with sufficient accuracy.

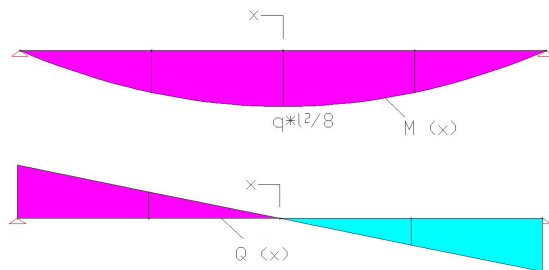

$$Msd(x) = qsd \cdot L^2 / 8 - qsd \cdot x^2 / 2$$
$$Qsd(x) = qsd \cdot x$$

$$NRd_G = 52,45 \text{ kN}$$
$$MRd_G = 61,63 \text{ kNcm}$$

$$M\text{-}Q \text{ Interaction} \quad Msd(x) / (0,303 \cdot 52,45) + Qsd(x) \cdot 2,25 / 61,63$$

$$\text{Extremum:} \quad d/dx \sigma(x) = 0$$

$$\Rightarrow x = 0,303 \cdot 52,45 \cdot 2,25 / 61,63 = 0,58 \text{ m}$$

(from middle of span)

### 2. Loading with **single-point loads** without requirements for position of couplers

No requirements for position of coupler (Distance between load and coupler is  $e$ , see below). The allowable loads of this case have to be regarded, if the distance between coupler and load is  $< 1,0 \text{ m}$ .

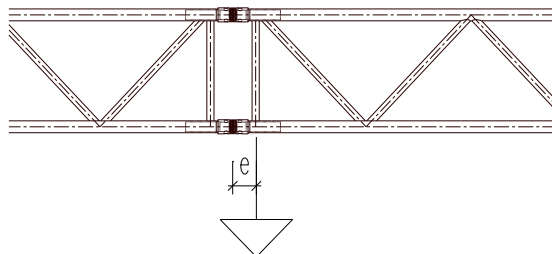



### 3. Alternative to (2): Loading with single-point loads with requirements for position of couplers

In this case it is assumed, that the coupler is located  $>1,0\text{m}$  from the loading-point. The coupler has to be located in a manner, so that the distance is  $>1,0\text{m}$  into the direction of the support-point.

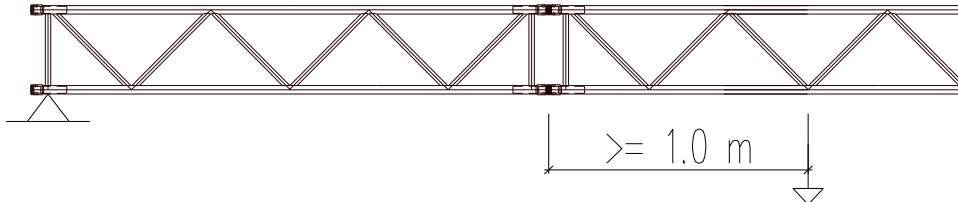

#### Summary

Following points are relevant for the determination of the allowable loads:

1. Allowable normal force in main chord ( $NR_{dG}$ )  
Main chord in heat affected zone at coupler is relevant  $\Rightarrow NR_{dG} = 52,45 \text{ kN}$
2. Global shear force in truss ( $Q$ )  
Allowable normal force in diagonals at nodes (HAZ) is relevant  $\Rightarrow NR_{dD} = 24,55 \text{ kN}$   
allowable shear force:  $Q_{Rd} / (2 \cdot \sin 34,5^\circ \cdot \cos 60^\circ) < 0,9 \cdot NR_{dD}$   
(10% reduction because of minor stresses)  
 $\Rightarrow \text{all. } QR_d = 0,9 \cdot 24,55 \cdot 2 \cdot \sin 34,5^\circ \cdot \cos 60^\circ \Rightarrow QR_d = 12,49 \text{ kN}$
3. Interaction bending and normal force at coupler see pg. 13





## 5 ALLOWABLE LOADING SINGLE SPAN GIRDER

### 5.1 Uniformly distributed load (UDL)

System:

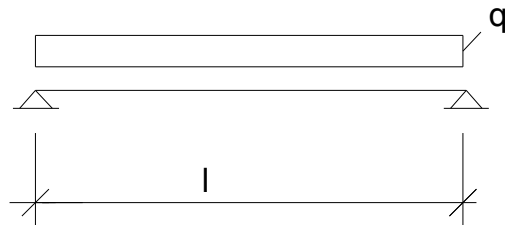

$$q_{sd} = p_{sd} + g_{sd}$$

(payload + selfweight, including safety)

Normal force in chord:

$$NR_d \geq q_{sd} \cdot L^2 / 8 / (n \cdot b)$$

$$\Rightarrow q_{sd} \leq NR_d \cdot (n \cdot b) \cdot 8 / L^2$$

$$\Rightarrow \text{zul } p = (NR_d \cdot (n \cdot b) \cdot 8 / L^2 - g_{sd}) / y_F$$

Normal force in diagonals:

$$QR_d \geq q_{sd} \cdot L / 2$$

$$\Rightarrow q_{sd} \leq QR_d \cdot 2 / L$$

$$\Rightarrow \text{zul } p = (QR_d \cdot 2 / L - g_{sd}) / y_F$$

Interaction at coupler:

Verification of interaction bending and normal force at coupler by an iterative method.

$$\Rightarrow (N_{sdG} / NR_{dG})^{1,3} + (M_{sdG} / MR_{dG}) < 1,0$$

applied: The coupler is located at  $e = 0,58$  m from the middle of the span  
(theoretically worst point, see extremum-calculation in chapter 4)

Loading-table: see next page



Loading table:

The coupler is located at  $e = 0,580$  from the middle of the span  
(theoretically worst point, see extremum-calculation in chapter 4)

### Uniformly distributed load UDL

L [m]	allowable load as a function of			min zul q [kN/m]
	Nrd	Qrd	Interaction at coupler	
	zul q [kN/m]	zul q [kN/m]	zul q [kN/m]	
4,00	5,23	4,10	4,98	4,10
5,00	3,32	3,26	3,22	3,22
6,00	2,29	2,71	2,24	2,24
7,00	1,66	2,31	1,64	1,64
8,00	1,26	2,01	1,24	1,24
9,00	0,98	1,78	0,97	0,97
10,00	0,78	1,60	0,77	0,77
11,00	0,63	1,45	0,63	0,63
12,00	0,52	1,32	0,52	0,52
13,00	0,43	1,21	0,43	0,43
14,00	0,36	1,12	0,36	0,36
15,00	0,31	1,04	0,31	0,31
16,00	0,26	0,97	0,26	0,26
17,00	0,23	0,91	0,23	0,23
18,00	0,19	0,86	0,19	0,19
19,00	0,17	0,81	0,17	0,17
20,00	0,14	0,77	0,14	0,14



## 5.2 Single-load in 1/2 point

System

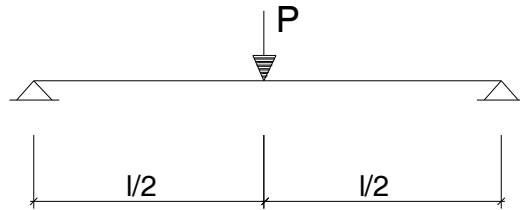

Normal force in chord:

$$NRd \geq (Psd \cdot L / 4 + gsd \cdot L^2 / 8) / (n \cdot b)$$

$$\Rightarrow Psd \leq [NRd \cdot (n \cdot b) - gsd \cdot L^2 / 8] \cdot 4 / L$$

$$\Rightarrow \text{zul } P = [NRd \cdot (n \cdot b) - gsd \cdot L^2 / 8] \cdot 4 / L / yF$$

Normal force in diagonals:

$$QRd \geq Psd / 2 + gsd \cdot L / 2$$

$$\Rightarrow Psd \leq (QRd - gsd \cdot L / 2) \cdot 2$$

$$\Rightarrow \text{zul } P = (QRd - gsd \cdot L / 2) \cdot 2 / yF$$

Interaction at coupler:

Verification of interaction bending and normal force at coupler by an iterative method.

$$\Rightarrow (Nsd_G / NRd_G)^{1,3} + (Msd_G / MRd_G) < 1,0$$

applied: Loading point at coupler

e = 0,08 m

Alternatively: Location of coupler from loading point  $\geq 1,0$  m

Loading-tables:

see next pages



Loading point at coupler

$e = 0,08$  m

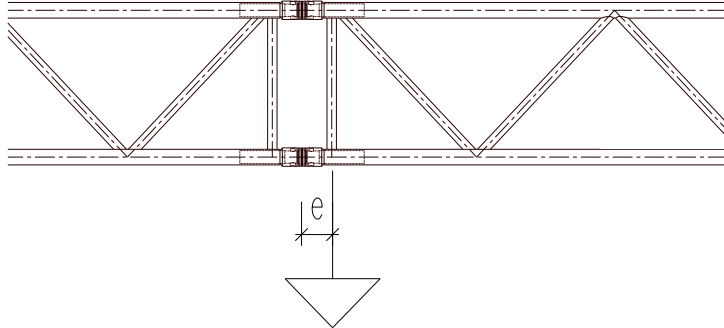

### Single-load in 1/2point

L [m]	allowable load as a function of			
	Nrd	Qrd	Interaction at coupler	
	zul P [kN]	zul P [kN]	0,08	= e [m]
	zul P [kN]	zul P [kN]	zul P [kN]	min zul P [kN]
4,00	10,46	16,38	8,77	8,77
5,00	8,31	16,32	7,21	7,21
6,00	6,86	16,25	6,09	6,09
7,00	5,82	16,18	5,25	5,25
8,00	5,03	16,11	4,59	4,59
9,00	4,41	16,05	4,07	4,07
10,00	3,90	15,98	3,63	3,63
11,00	3,48	15,91	3,26	3,26
12,00	3,13	15,84	2,94	2,94
13,00	2,82	15,78	2,67	2,67
14,00	2,55	15,71	2,43	2,43
15,00	2,32	15,64	2,21	2,21
16,00	2,11	15,57	2,02	2,02
17,00	1,92	15,51	1,84	1,84
18,00	1,75	15,44	1,68	1,68
19,00	1,59	15,37	1,53	1,53
20,00	1,44	15,30	1,39	1,39



Location of coupler from loading point  $e \geq 1,0$  m

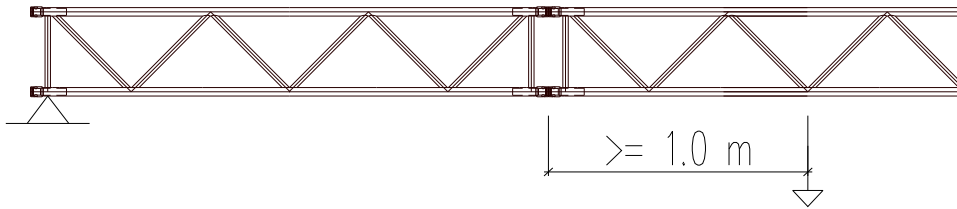

### Single-load in 1/2point

L [m]	allowable load as a function of			
	Nrd	Qrd	Interaction at coupler	
	zul P [kN]	zul P [kN]	1	= e [m]
4,00	10,46	16,38	14,11	10,46
5,00	8,31	16,32	10,49	8,31
6,00	6,86	16,25	8,31	6,86
7,00	5,82	16,18	6,85	5,82
8,00	5,03	16,11	5,79	5,03
9,00	4,41	16,05	5,00	4,41
10,00	3,90	15,98	4,37	3,90
11,00	3,48	15,91	3,86	3,48
12,00	3,13	15,84	3,44	3,13
13,00	2,82	15,78	3,08	2,82
14,00	2,55	15,71	2,77	2,55
15,00	2,32	15,64	2,50	2,32
16,00	2,11	15,57	2,27	2,11
17,00	1,92	15,51	2,05	1,92
18,00	1,75	15,44	1,86	1,75
19,00	1,59	15,37	1,69	1,59
20,00	1,44	15,30	1,53	1,44



### 5.3 Single-loads in 1/3 points

System

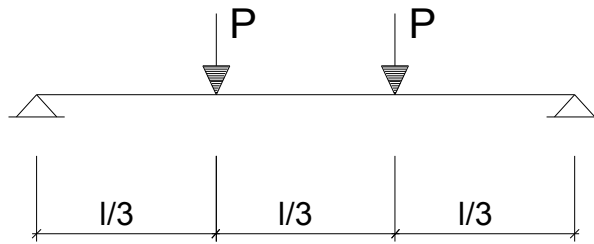

Normal force in chord:

$$NRd \geq (P_{sd} \cdot L / 3 + g_{sd} \cdot L^2 / 8) / (n \cdot b)$$

$$\Rightarrow P_{sd} \leq [NRd \cdot (n \cdot b) - g_{sd} \cdot L^2 / 8] \cdot 3 / L$$

$$\Rightarrow \text{zul } P = [NRd \cdot (n \cdot b) - g_{sd} \cdot L^2 / 8] \cdot 3 / L / y_F$$

Normal force in diagonals

$$QRd \geq P_{sd} / 2 + g_{sd} \cdot L / 2$$

$$\Rightarrow P_{sd} \leq (QRd - g_{sd} \cdot L / 2)$$

$$\Rightarrow \text{zul } P = (QRd - g_{sd} \cdot L / 2) / y_F$$

Interaction at coupler

Verification of interaction bending and normal force at coupler by an iterative method.

$$\Rightarrow (N_{sdG} / NR_{dG})^{1,3} + (M_{sdG} / MR_{dG}) < 1,0$$

applied: Loading point at coupler

$$e = 0,08 \text{ m}$$

Alternatively: Location of coupler from loading point  $\geq 1,0 \text{ m}$

Loading-tables: see next pages



Loading point at coupler

$e = 0,08 \text{ m}$

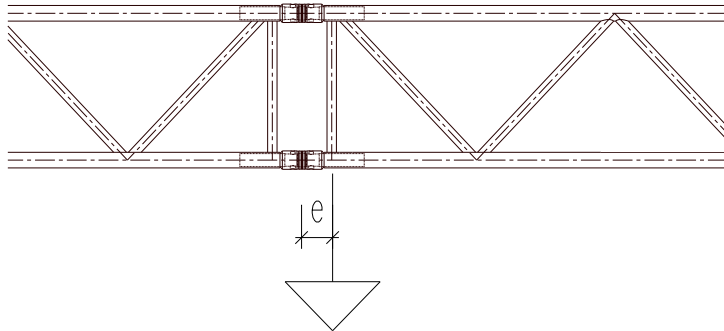

### Single-load in 1/3points

L [m]	allowable load as a function of			
	Nrd	Qrd	Interaction at coupler	= e [m]
	zul P [kN]	zul P [kN]	0,08 zul P [kN]	
4,00	7,84	8,19	6,07	6,07
5,00	6,23	8,16	5,06	5,06
6,00	5,15	8,12	4,32	4,32
7,00	4,36	8,09	3,76	3,76
8,00	3,77	8,06	3,31	3,31
9,00	3,30	8,02	2,94	2,94
10,00	2,93	7,99	2,64	2,64
11,00	2,61	7,96	2,38	2,38
12,00	2,34	7,92	2,16	2,16
13,00	2,12	7,89	1,97	1,97
14,00	1,92	7,85	1,80	1,80
15,00	1,74	7,82	1,65	1,65
16,00	1,58	7,79	1,51	1,51
17,00	1,44	7,75	1,38	1,38
18,00	1,31	7,72	1,27	1,27
19,00	1,19	7,69	1,16	1,16
20,00	1,08	7,65	1,07	1,07



Location of coupler from loading point

$e \geq 1,0 \text{ m}$

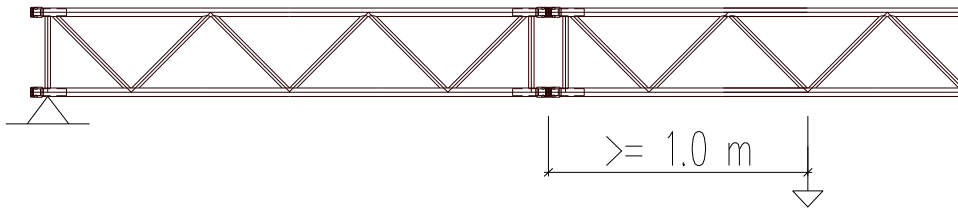

### Single-load in 1/3points

L [m]	allowable load as a function of			
	Nrd	Qrd	Interaction at coupler	
	zul P [kN]	zul P [kN]	1	= e [m]
4,00	7,84	8,19	12,56	7,84
5,00	6,23	8,16	9,05	6,23
6,00	5,15	8,12	6,99	5,15
7,00	4,36	8,09	5,67	4,36
8,00	3,77	8,06	4,74	3,77
9,00	3,30	8,02	4,06	3,30
10,00	2,93	7,99	3,53	2,93
11,00	2,61	7,96	3,11	2,61
12,00	2,34	7,92	2,77	2,34
13,00	2,12	7,89	2,48	2,12
14,00	1,92	7,85	2,23	1,92
15,00	1,74	7,82	2,02	1,74
16,00	1,58	7,79	1,83	1,58
17,00	1,44	7,75	1,67	1,44
18,00	1,31	7,72	1,52	1,31
19,00	1,19	7,69	1,38	1,19
20,00	1,08	7,65	1,26	1,08





#### 5.4 Single-loads in 1/4 points

System

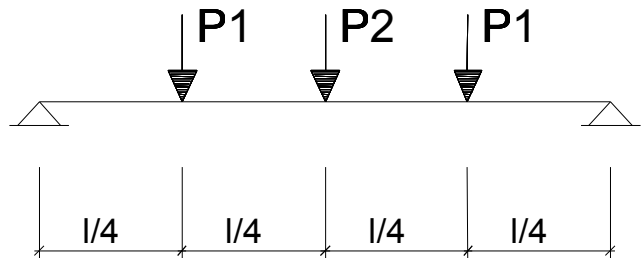

Normal force in chord:

$$NRd \geq (P_{sd} \cdot L / 4 + g_{sd} \cdot L^2 / 8) / (n \cdot b)$$

$$\Rightarrow P_{sd} \leq [NRd \cdot (n \cdot b) - g_{sd} \cdot L^2 / 8] \cdot 2 / L$$

$$\Rightarrow \text{zul } P = [NRd \cdot (n \cdot b) - g_{sd} \cdot L^2 / 8] \cdot 2 / L / \gamma_F$$

Normal force in diagonals:

$$QRd \geq 3 / 2 \cdot P_{sd} + g_{sd} \cdot L / 2$$

$$\Rightarrow P_{sd} \leq (QRd - g_{sd} \cdot L / 2) \cdot 2 / 3$$

$$\Rightarrow \text{zul } P = (QRd - g_{sd} \cdot L / 2) \cdot 2 / 3 / \gamma_F$$

Interaction at coupler

Verification of interaction bending and normal force at coupler by an iterative method.

$$\Rightarrow (N_{sdG} / NR_{dG})^{1,3} + (M_{sdG} / MR_{dG}) < 1,0$$

applied: Loading point at coupler

$$e = 0,08 \text{ m}$$

Alternatively: Location of coupler from loading point  $\geq 1,0 \text{ m}$

Loading-tables:

see next pages



Loading point at coupler

$e = 0,08 \text{ m}$

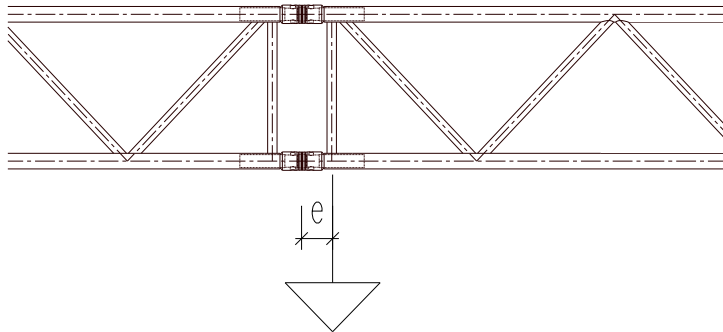

### Single-load in 1/4points

L [m]	allowable load as a function of				
	Nrd	Qrd	Interaction at coupler 1	Interaction at coupler 2	= e [m]
	zul P [kN]	zul P [kN]	0,08 zul P [kN]	0,08 zul P [kN]	
4,00	5,23	5,46	4,98	4,78	4,78
5,00	4,15	5,44	4,25	3,86	3,86
6,00	3,43	5,42	3,69	3,23	3,23
7,00	2,91	5,39	3,26	2,76	2,76
8,00	2,51	5,37	2,90	2,40	2,40
9,00	2,20	5,35	2,60	2,11	2,11
10,00	1,95	5,33	2,35	1,88	1,88
11,00	1,74	5,30	2,13	1,68	1,68
12,00	1,56	5,28	1,94	1,52	1,52
13,00	1,41	5,26	1,77	1,37	1,37
14,00	1,28	5,24	1,62	1,24	1,24
15,00	1,16	5,21	1,49	1,13	1,13
16,00	1,05	5,19	1,36	1,03	1,03
17,00	0,96	5,17	1,25	0,94	0,94
18,00	0,87	5,15	1,15	0,86	0,86
19,00	0,79	5,12	1,05	0,78	0,78
20,00	0,72	5,10	0,96	0,71	0,71



Location of coupler from loading point

$e \geq 1,0 \text{ m}$

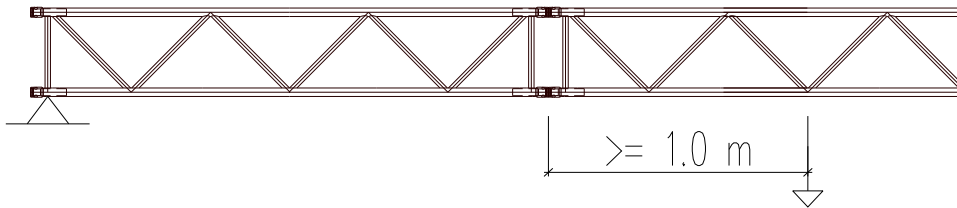

### Single-load in 1/4points

L [m]	allowable load as a function of				= e [m]
	Nrd	Qrd	Interaction at coupler 1	Interaction at coupler 2	
	zul P [kN]	zul P [kN]	1	1	
	zul P [kN]	zul P [kN]	zul P [kN]	zul P [kN]	min zul P [kN]
4,00	5,23	5,46	11,97	6,07	5,23
5,00	4,15	5,44	9,55	4,67	4,15
6,00	3,43	5,42	7,50	3,78	3,43
7,00	2,91	5,39	6,06	3,16	2,91
8,00	2,51	5,37	5,03	2,70	2,51
9,00	2,20	5,35	4,26	2,35	2,20
10,00	1,95	5,33	3,66	2,07	1,95
11,00	1,74	5,30	3,19	1,83	1,74
12,00	1,56	5,28	2,81	1,64	1,56
13,00	1,41	5,26	2,49	1,47	1,41
14,00	1,28	5,24	2,22	1,33	1,28
15,00	1,16	5,21	1,99	1,20	1,16
16,00	1,05	5,19	1,79	1,09	1,05
17,00	0,96	5,17	1,61	0,99	0,96
18,00	0,87	5,15	1,45	0,90	0,87
19,00	0,79	5,12	1,31	0,82	0,79
20,00	0,72	5,10	1,18	0,74	0,72



### 5.5 Single-loads in 1/5 points

System

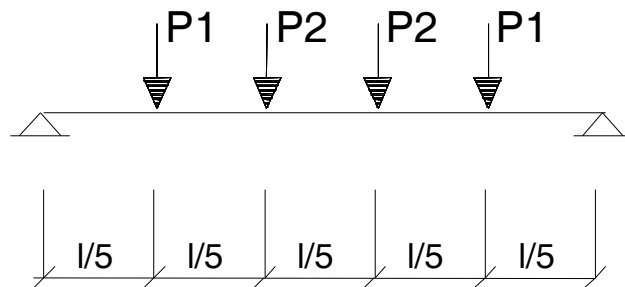

Normal force in chord:

$$NRd \geq (P_{sd} \cdot 3/5 \cdot L + g_{sd} \cdot L^2 / 8) / (n \cdot b)$$

$$\Rightarrow P_{sd} \leq [NRd \cdot (n \cdot b) - g_{sd} \cdot L^2 / 8] \cdot 5 / 3$$

$$\Rightarrow \text{zul } P = [NRd \cdot (n \cdot b) - g_{sd} \cdot L^2 / 8] \cdot 5 / 3 / L / y_F$$

Normal force in diagonals:

$$QRd \geq 2 \cdot P_{sd} + g_{sd} \cdot L / 2$$

$$\Rightarrow P_{sd} \leq (QRd - g_{sd} \cdot L / 2) / 2$$

$$\Rightarrow \text{zul } P = (QRd - g_{sd} \cdot L / 2) / 2 / y_F$$

Interaction at coupler:

Verification of interaction bending and normal force at coupler by an iterative method.

$$\Rightarrow (N_{sdG} / NR_{dG})^{1,3} + (M_{sdG} / MR_{dG}) < 1,0$$

applied: Loading point at coupler

$e = 0,08 \text{ m}$

Alternatively: Location of coupler from loading point  $\geq 1,0 \text{ m}$

Loading-tables: see next pages



Loading point at coupler

$e = 0,08$  m

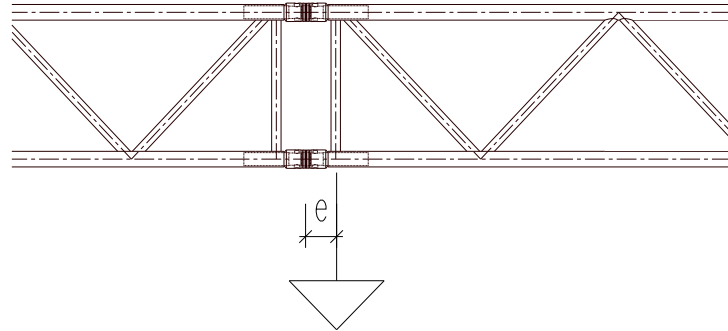

### Single-load in 1/5points

	allowable load as a function of				
	Nrd	Qrd	Interaction at coupler 1	Interaction at coupler 2	
			0,08	0,08	= e [m]
L [m]	zul P [kN]	zul P [kN]	zul P [kN]	zul P [kN]	min zul P [kN]
4,00	4,36	4,10	4,41	3,76	3,76
5,00	3,46	4,08	3,79	3,07	3,07
6,00	2,86	4,06	3,33	2,59	2,59
7,00	2,42	4,05	2,96	2,22	2,22
8,00	2,09	4,03	2,65	1,94	1,94
9,00	1,84	4,01	2,40	1,72	1,72
10,00	1,63	3,99	2,17	1,53	1,53
11,00	1,45	3,98	1,98	1,37	1,37
12,00	1,30	3,96	1,81	1,24	1,24
13,00	1,18	3,94	1,66	1,12	1,12
14,00	1,06	3,93	1,53	1,02	1,02
15,00	0,97	3,91	1,40	0,93	0,93
16,00	0,88	3,89	1,29	0,85	0,85
17,00	0,80	3,88	1,19	0,78	0,78
18,00	0,73	3,86	1,09	0,71	0,71
19,00	0,66	3,84	1,00	0,65	0,65
20,00	0,60	3,83	0,92	0,59	0,59



Location of coupler from loading point

$e \geq 1,0 \text{ m}$

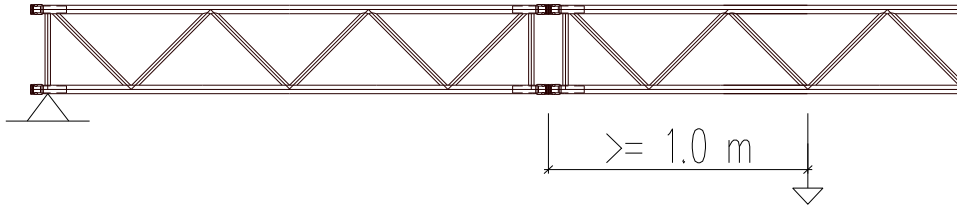

### Single-load in 1/5points

	allowable load as a function of				
	Nrd	Qrd	Interaction at coupler 1	Interaction at coupler 2	
			1	1	= e [m]
L [m]	zul P [kN]	zul P [kN]	zul P [kN]	zul P [kN]	min zul P [kN]
4,00	4,36	4,10	not relevant	not relevant	4,10
5,00	3,46	4,08	8,91	4,24	3,46
6,00	2,86	4,06	7,50	3,38	2,86
7,00	2,42	4,05	6,16	2,80	2,42
8,00	2,09	4,03	5,13	2,38	2,09
9,00	1,84	4,01	4,35	2,06	1,84
10,00	1,63	3,99	3,74	1,80	1,63
11,00	1,45	3,98	3,26	1,60	1,45
12,00	1,30	3,96	2,86	1,43	1,30
13,00	1,18	3,94	2,53	1,28	1,18
14,00	1,06	3,93	2,26	1,15	1,06
15,00	0,97	3,91	2,02	1,05	0,97
16,00	0,88	3,89	1,82	0,95	0,88
17,00	0,80	3,88	1,64	0,86	0,80
18,00	0,73	3,86	1,47	0,78	0,73
19,00	0,66	3,84	1,33	0,71	0,66
20,00	0,60	3,83	1,20	0,65	0,60



## 6 SUMMARY OF THE RESULTS

### 6.1 Allowable loadings

#### Allowable Load F43P

single-span beam

Span	UDL	Single point loads			
		in 1/2 Point	in 1/3 Points	in 1/4 Points	in 1/5 Points
[m]	[kN/m]	[kN]	[kN]	[kN]	[kN]
4	4,10	8,77	6,07	4,78	3,76
5	3,22	7,21	5,06	3,86	3,07
6	2,24	6,09	4,32	3,23	2,59
7	1,64	5,25	3,76	2,76	2,22
8	1,24	4,59	3,31	2,40	1,94
9	0,97	4,07	2,94	2,11	1,72
10	0,77	3,63	2,64	1,88	1,53
11	0,63	3,26	2,38	1,68	1,37
12	0,52	2,94	2,16	1,52	1,24
13	0,43	2,67	1,97	1,37	1,12
14	0,36	2,43	1,80	1,24	1,02
15	0,31	2,21	1,65	1,13	0,93
16	0,26	2,02	1,51	1,03	0,85
17	0,23	1,84	1,38	0,94	0,78
18	0,19	1,68	1,27	0,86	0,71
19	0,17	1,53	1,16	0,78	0,65
20	0,14	1,39	1,07	0,71	0,59

The values of the table are only valid for single-span girder.

The truss-elements have to be braced with diagonals.

Large loads have to be applied at the nodes or have to be distributed by appropriate constructions.

Loads at the middle of the couplers are not allowed.

All loads have to be distributed equally to both chords.

The specified values include partial safety coefficients on the loadings side acc. EN 1990 of  $\gamma_F = 1.50$  for payloads and  $\gamma_G = 1.35$  for selfweight of the truss.

For applications which can be calculated on the basis of other codes, the partial safety factors can be adjusted (for example temporary structures acc. EN 13814,  $\gamma_F = 1.35$  for payloads).



To use the resulting allowable loads with British Standard (BS) and ANSI, allowable loads listed in tables have to be multiplied by 0.85.

The values are calculated with no requirements for the location of the couplers. In case that the distance from the couplers to the loading points of the single-point loads is  $\geq 1,0$  m into the direction of the support, the values of the calculations for the different loadcases can be used (see chapter 5).

## 6.2 Deflections at max. allowable loadings

### Deflections [cm] for F43P at max. allowable loads

[cm]

Span	UDL	Single point loads			
		in 1/2 Point	in 1/3 Points	in 1/4 Points	in 1/5 Points
[m]	[cm]	[cm]	[cm]	[cm]	[cm]
4	0,72	0,62	0,73	0,80	0,80
5	1,39	1,01	1,20	1,27	1,29
6	2,03	1,49	1,79	1,86	1,90
7	2,78	2,07	2,50	2,56	2,62
8	3,65	2,76	3,33	3,37	3,47
9	4,64	3,54	4,29	4,30	4,43
10	5,75	4,44	5,38	5,34	5,52
11	6,97	5,44	6,60	6,51	6,74
12	8,32	6,56	7,95	7,79	8,08
13	9,80	7,80	9,44	9,20	9,55
14	11,40	9,16	11,06	10,73	11,14
15	13,12	10,65	12,82	12,39	12,87
16	14,98	12,27	14,73	14,18	14,74
17	16,96	14,02	16,78	16,11	16,74
18	19,08	15,93	18,99	18,17	18,88
19	21,33	17,98	21,35	20,37	21,17
20	23,72	20,19	23,88	22,71	23,60

 = Deflection  $\geq L/100$



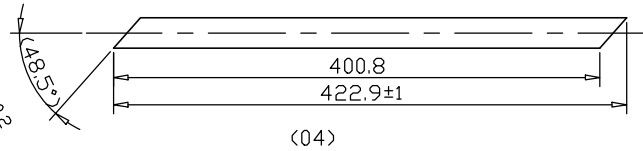
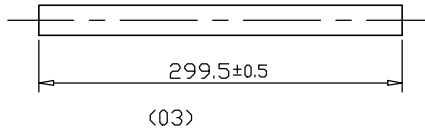
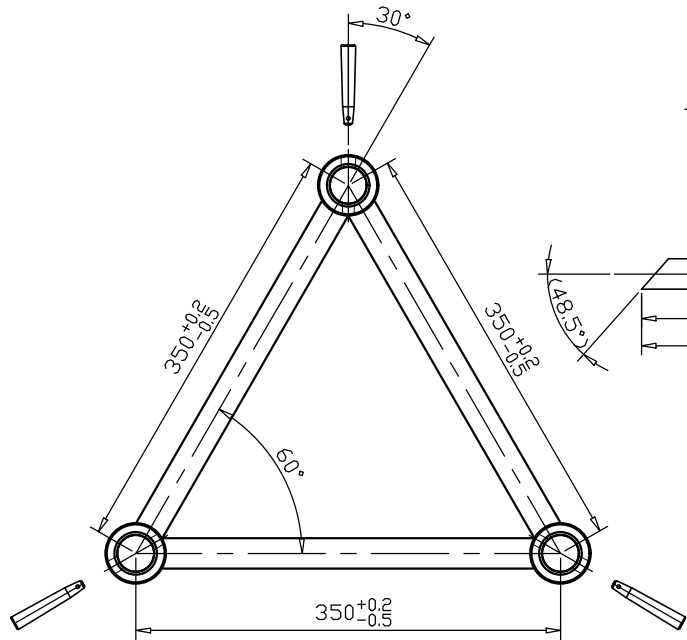
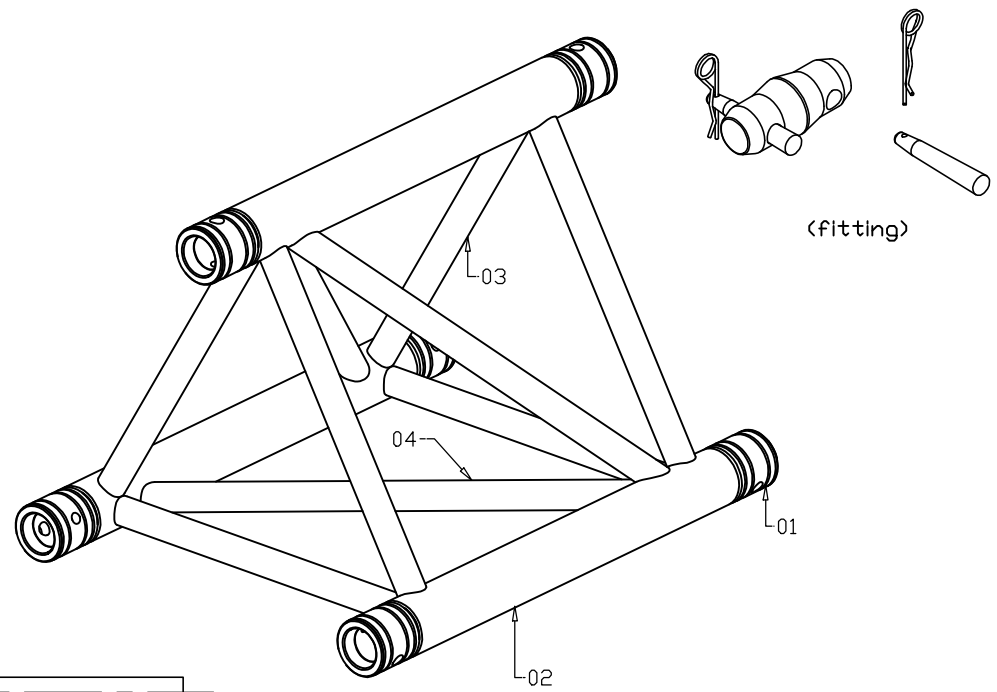
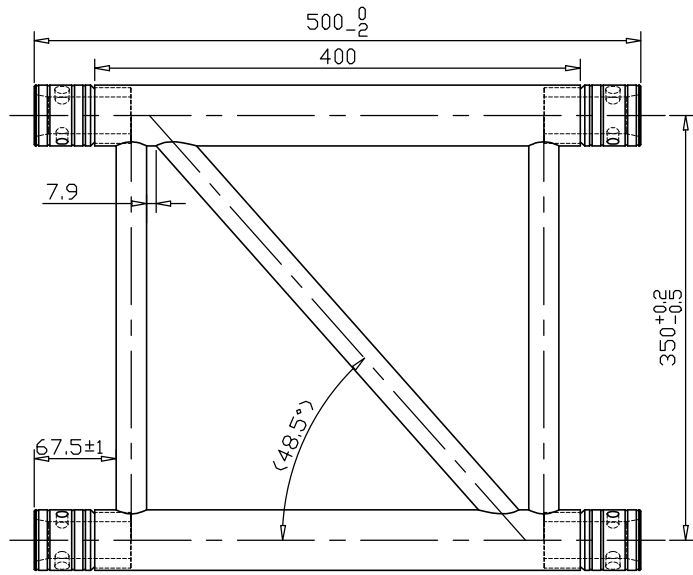

NO.	SPEC.	MATERIAL	FIN.	QTY.
fitting	DMS-01-1	Steel	ZP	6
	DMS-01-4	S45C	ZP	6
	DMS-01-3	#2011	T6	3
04	∅25*3.0t*422.9mm	#6082	T6	3
03	∅25*3.0t*299.5mm	#6082	T6	6
02	∅50*3.0t*400mm	#6082	T6	3
01	DMS-01-2CR	#6082	T6	6

DRAWN	F43P	DRAW NO	F43050P	2D/3D	edition	1	
Specification	F43P-0.5M	DESIGN	Qiu Rongyi	DATE	17.06.08	CHECKED	APPROVED
Weight	4.27kgs/pcs	UNITS	mm	Proofread			
SURFACE	RAW	SCALE	1:6				

MARK	NAME	RETRIEVE	CONTENTS	DATE



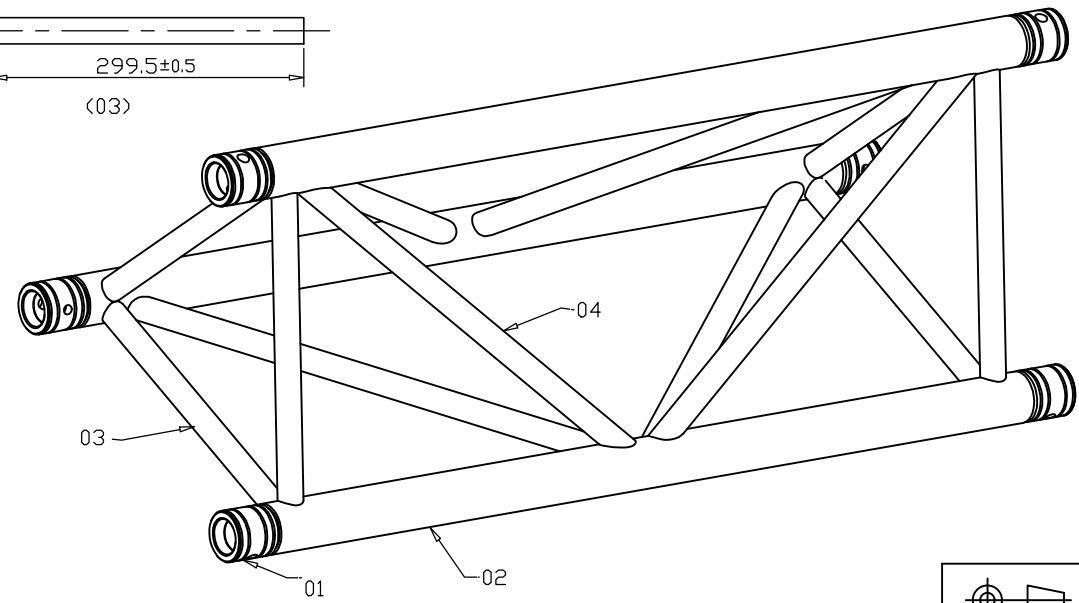
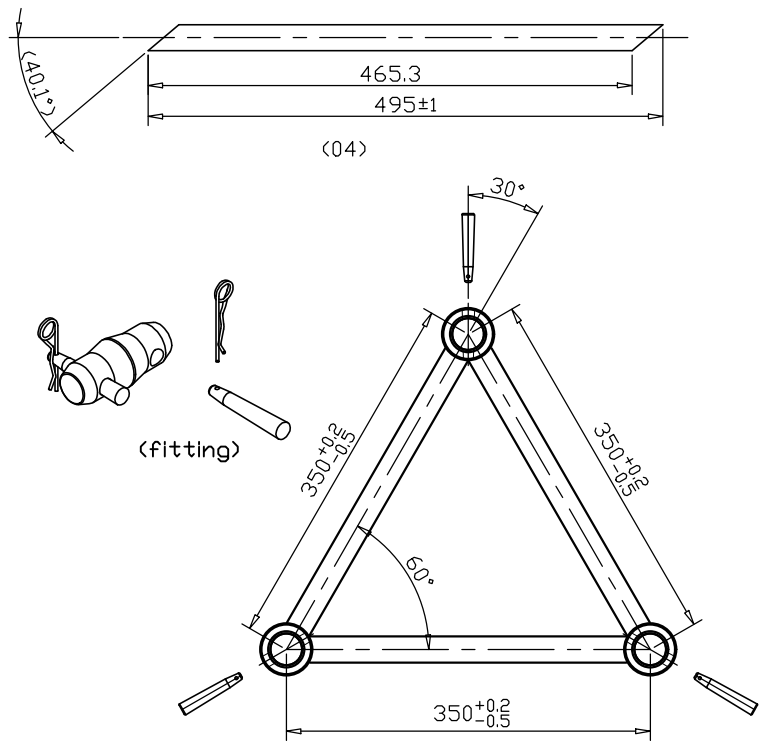
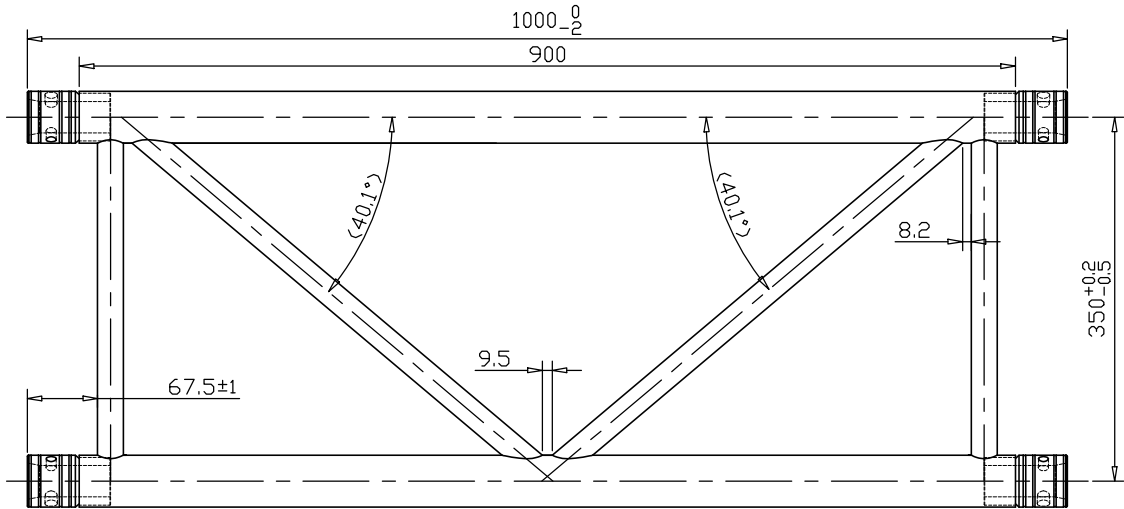

fitting	DMS-01-1	Steel	ZP	6
	DMS-01-4	S45C	ZP	6
	DMS-01-3	#2011	T6	3
04	∅25*3.0t*495mm	#6082	T6	6
03	∅25*3.0t*299.5mm	#6082	T6	6
02	∅50*3.0t*900mm	#6082	T6	3
01	DMS-01-2CR	#6082	T6	6
NO.	SPEC.	MATERIAL	FIN.	QTY.

	DRAWN	F43P	DRAW NO	F43100P	2D/3D	edition	1	
	Specification	F43P-1.0M	DESIGN	Qiu Rongyi	DATE	17.06.08	CHECKED	APPROVED
	Weight	581kgs/pcs	UNITS	mm	Proofread			
	SURFACE	RAW	SCALE	1:7				

MARK	NAME	RETRIEVE CONTENTS	DATE

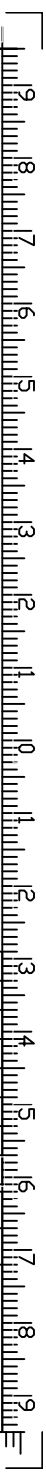

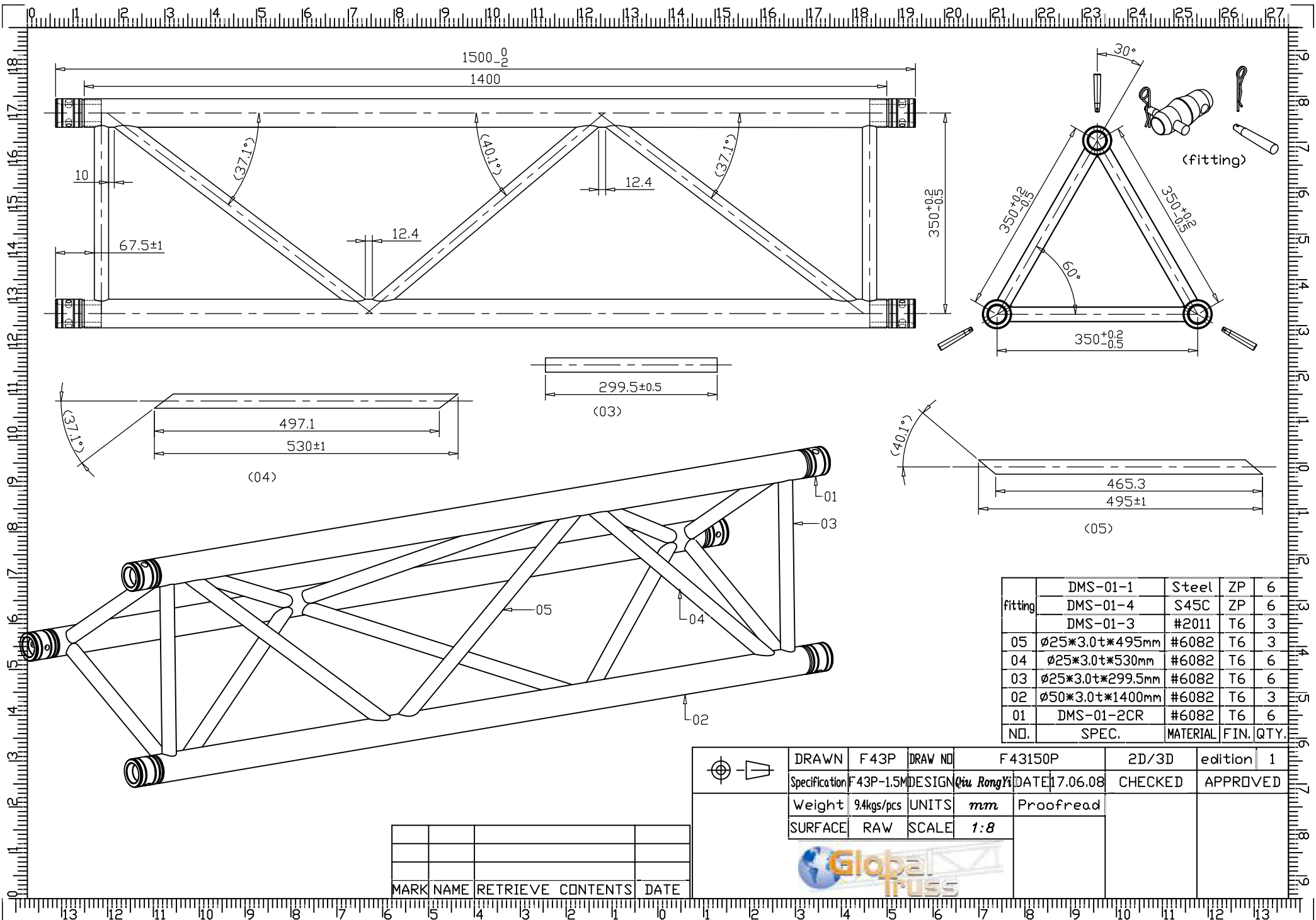

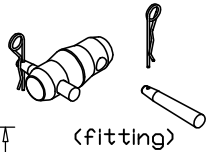
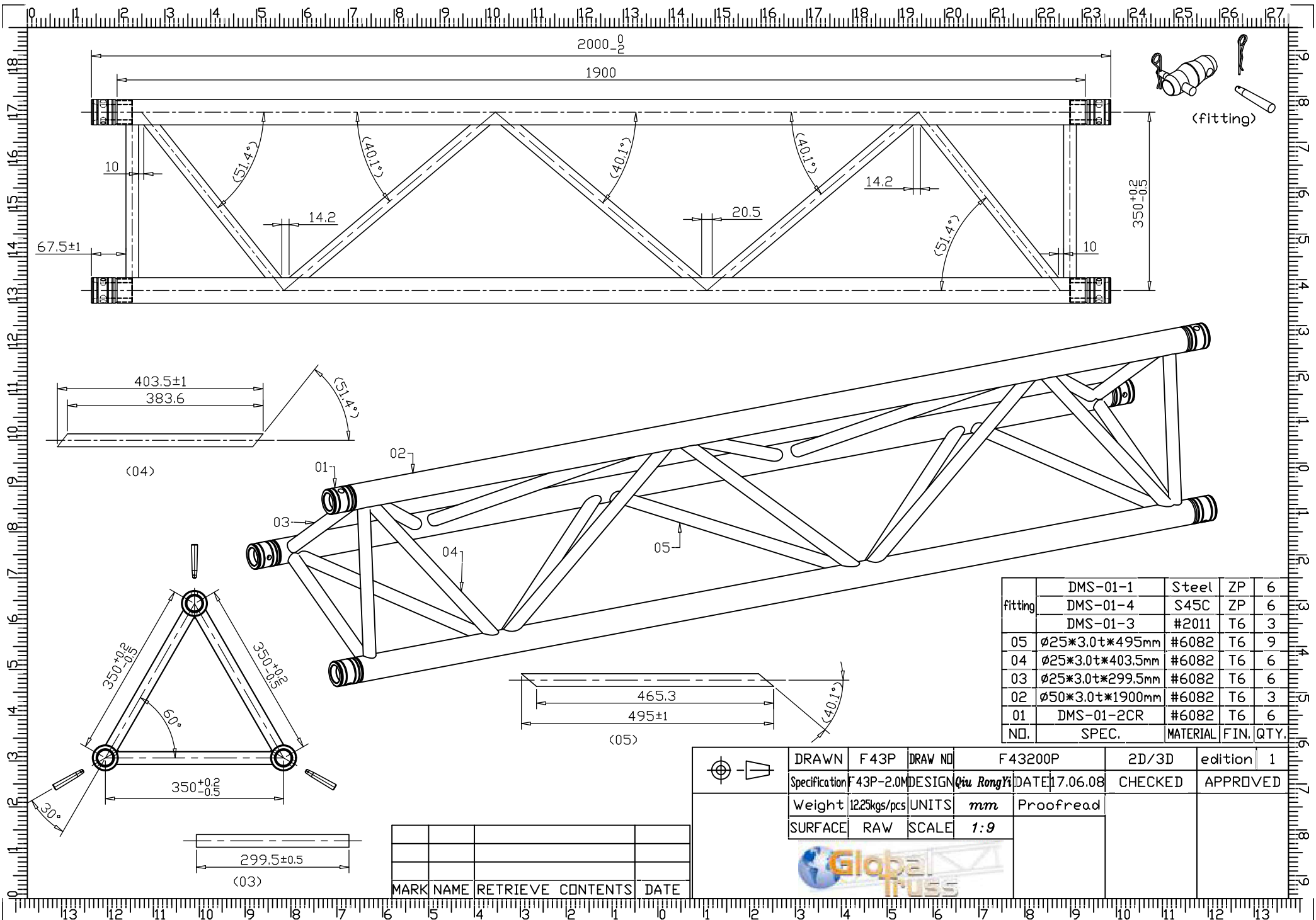

NO.	SPEC.	MATERIAL	FIN.	QTY.
fitting	DMS-01-1	Steel	ZP	6
	DMS-01-4	S45C	ZP	6
	DMS-01-3	#2011	T6	3
05	∅25*3.0t*495mm	#6082	T6	9
04	∅25*3.0t*403.5mm	#6082	T6	6
03	∅25*3.0t*299.5mm	#6082	T6	6
02	∅50*3.0t*1900mm	#6082	T6	3
01	DMS-01-2CR	#6082	T6	6

DRAWN	F43P	DRAW NO	F43200P	2D/3D	edition	1	
Specification	F43P-2.0M	DESIGN	Qiu Rongyi	DATE	17.06.08	CHECKED	APPROVED
Weight	1225kgs/pcs	UNITS	mm	Proofread			
SURFACE	RAW	SCALE	1:9				



MARK	NAME	RETRIEVE	CONTENTS	DATE

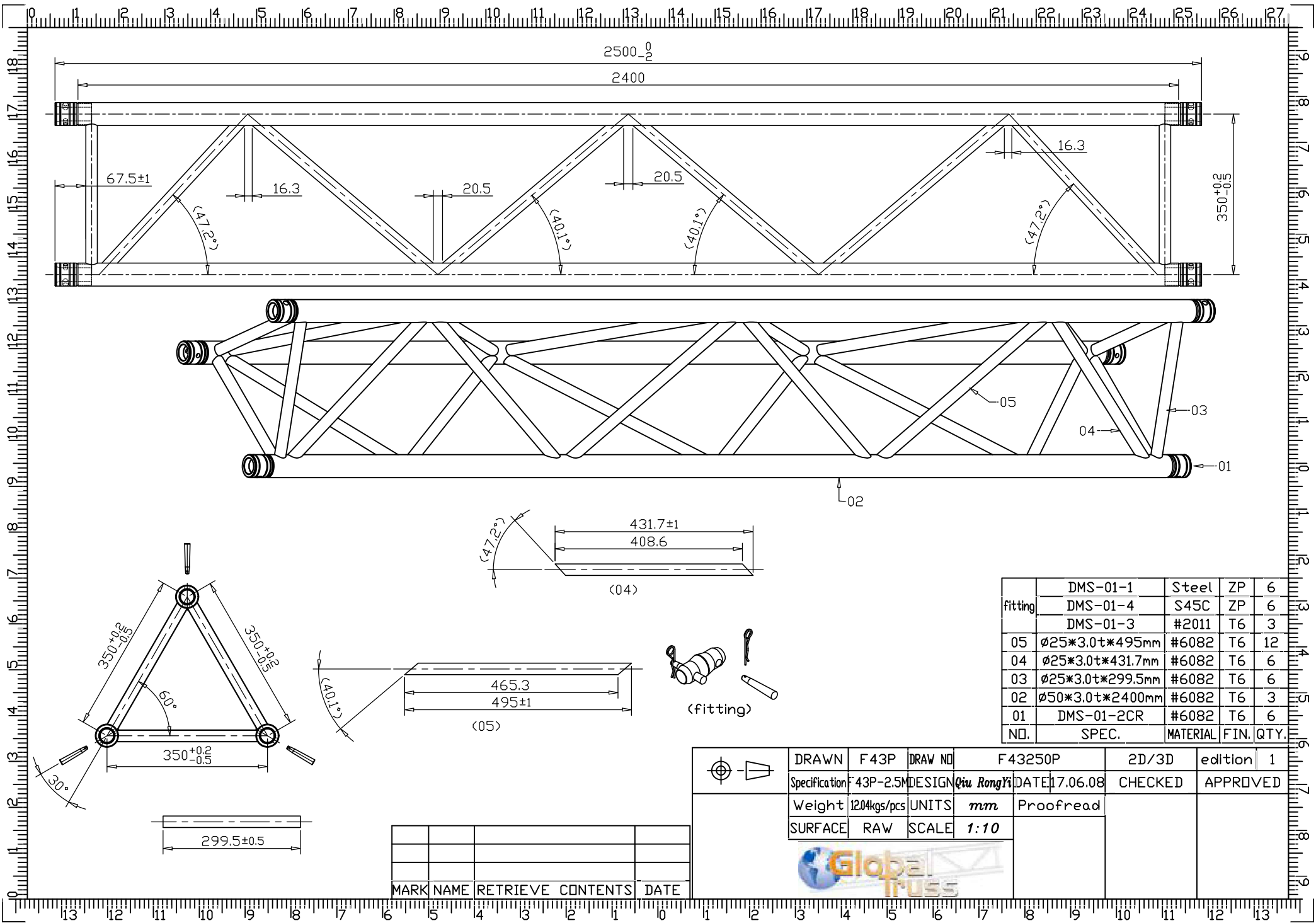

fitting	DMS-01-1	Steel	ZP	6
	DMS-01-4	S45C	ZP	6
	DMS-01-3	#2011	T6	3
05	∅25*3.0t*495mm	#6082	T6	12
04	∅25*3.0t*431.7mm	#6082	T6	6
03	∅25*3.0t*299.5mm	#6082	T6	6
02	∅50*3.0t*2400mm	#6082	T6	3
01	DMS-01-2CR	#6082	T6	6
NO.	SPEC.	MATERIAL	FIN.	QTY.

DRAWN	F43P	DRAW NO	F43250P	2D/3D	edition	1	
Specification	F43P-2.5M	DESIGN	Qiu Rongyi	DATE	17.06.08	CHECKED	APPROVED
Weight	1204kgs/pcs	UNITS	mm	Proofread			
SURFACE	RAW	SCALE	1:10				



MARK	NAME	RETRIEVE	CONTENTS	DATE

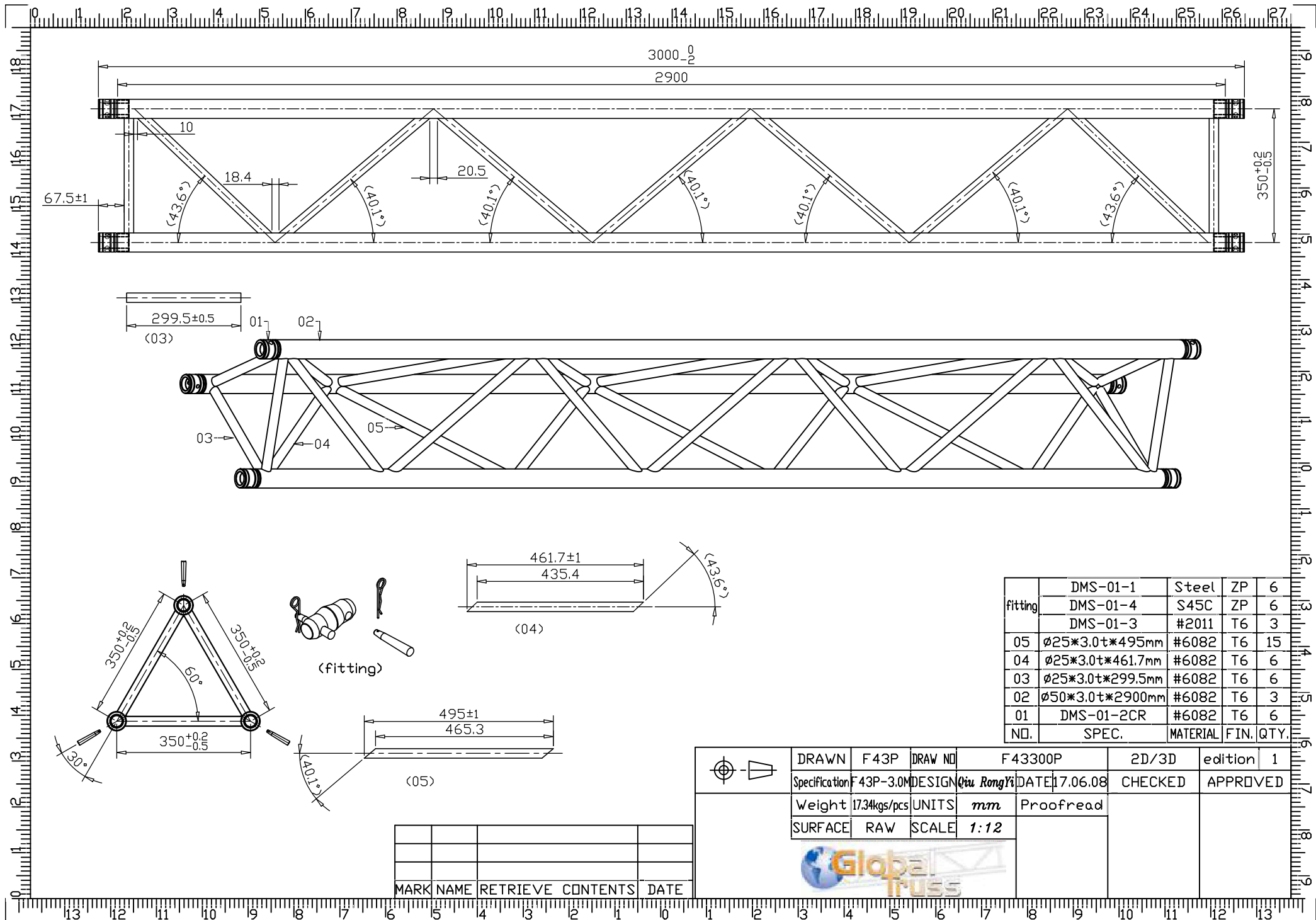

NO.	SPEC.	MATERIAL	FIN.	QTY.
05	∅25*3.0t*495mm	#6082	T6	15
04	∅25*3.0t*461.7mm	#6082	T6	6
03	∅25*3.0t*299.5mm	#6082	T6	6
02	∅50*3.0t*2900mm	#6082	T6	3
01	DMS-01-2CR	#6082	T6	6
fitting	DMS-01-1	Steel	ZP	6
	DMS-01-4	S45C	ZP	6
	DMS-01-3	#2011	T6	3

DRAWN	F43P	DRAW NO	F43300P	2D/3D	edition	1	
Specification	F43P-3.0M	DESIGN	Qiu Rongyi	DATE	17.06.08	CHECKED	APPROVED
Weight	17.34kgs/pcs	UNITS	mm	Proofread			
SURFACE	RAW	SCALE	1:12				

MARK	NAME	RETRIEVE	CONTENTS	DATE



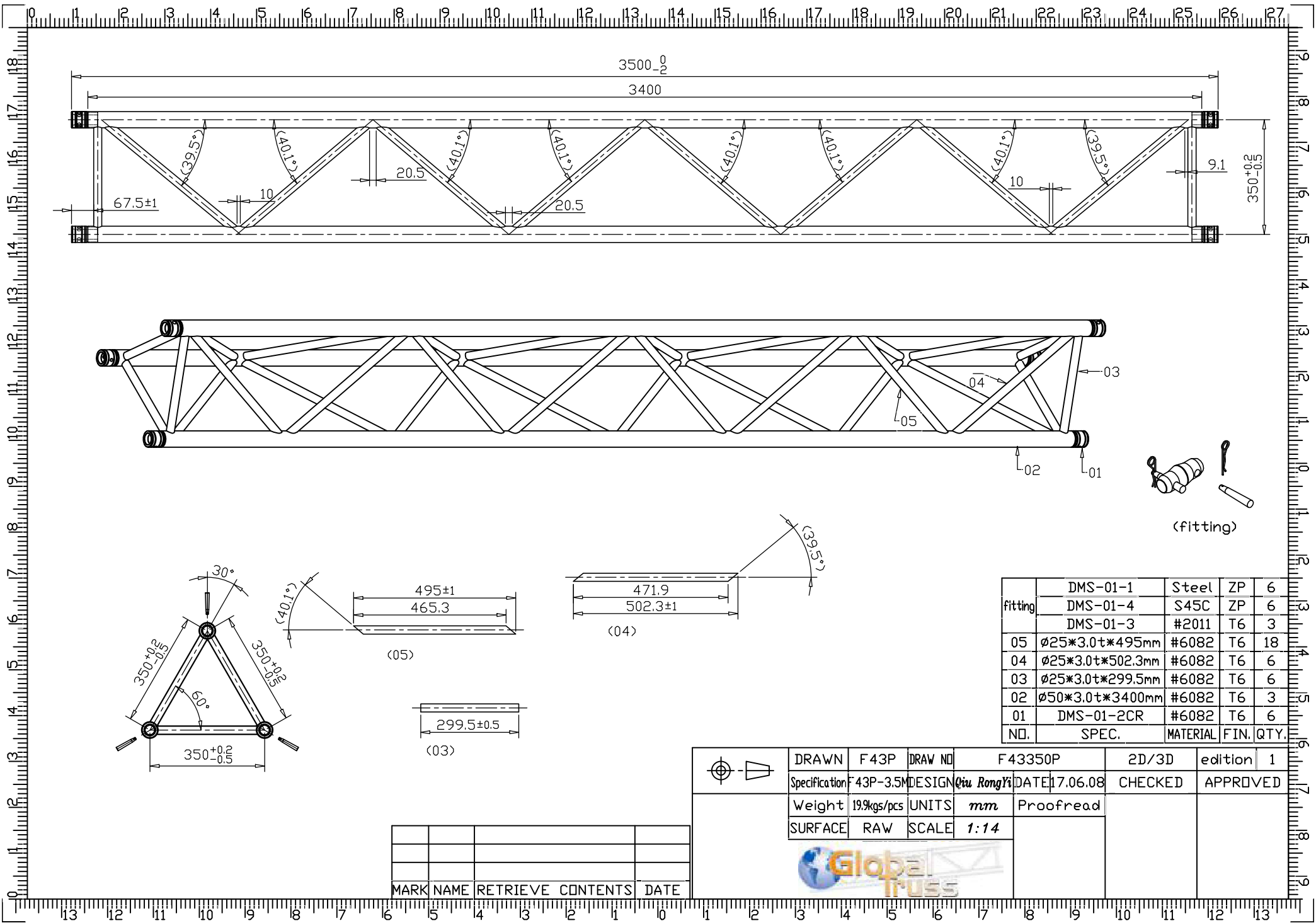

DRAWN	F43P	DRAW NO	F43350P	2D/3D	edition	1
Specification	F43P-3.5M	DESIGN	Qiu Rongyi	DATE	17.06.08	CHECKED APPROVED
Weight	199kgs/pcs	UNITS	mm	Proofread		
SURFACE	RAW	SCALE	1:14			





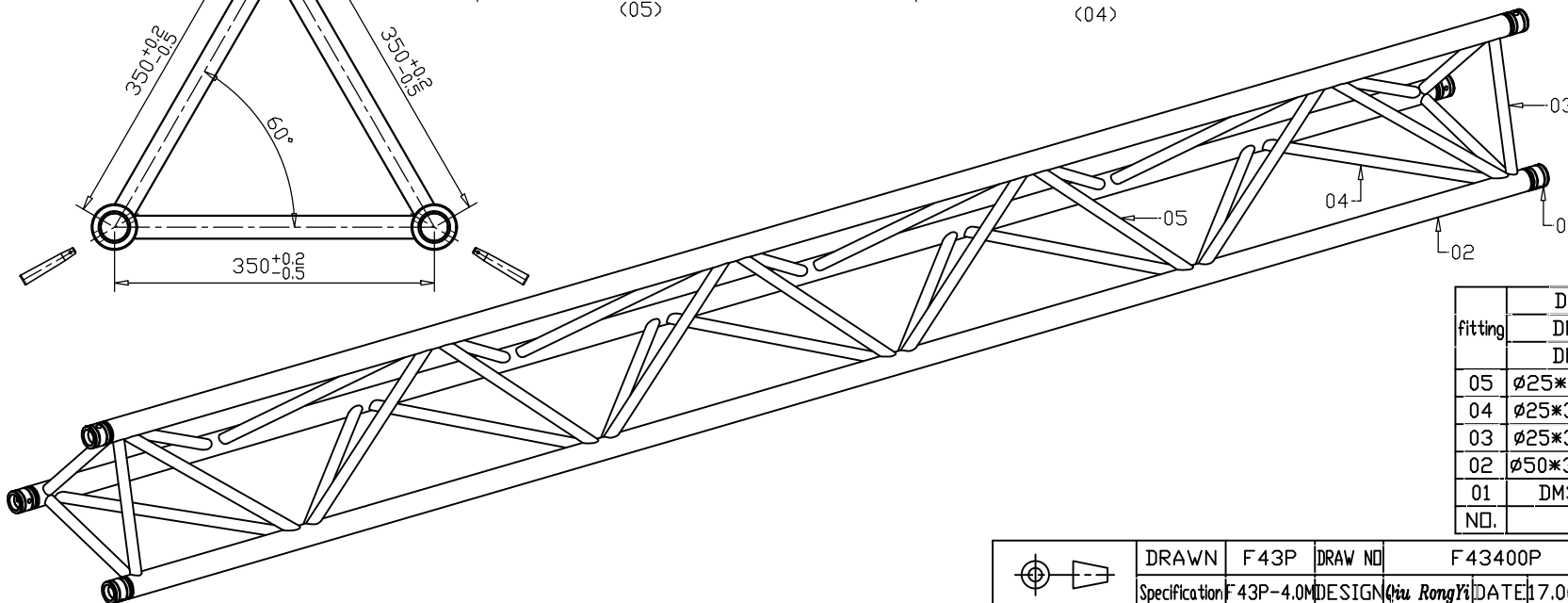
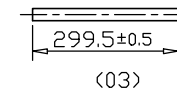
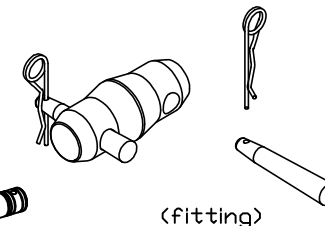
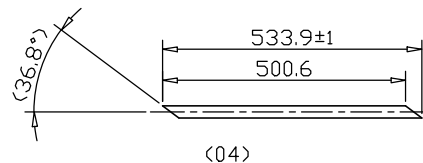
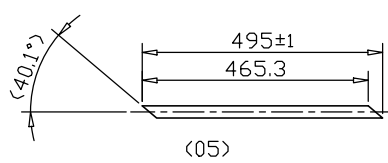
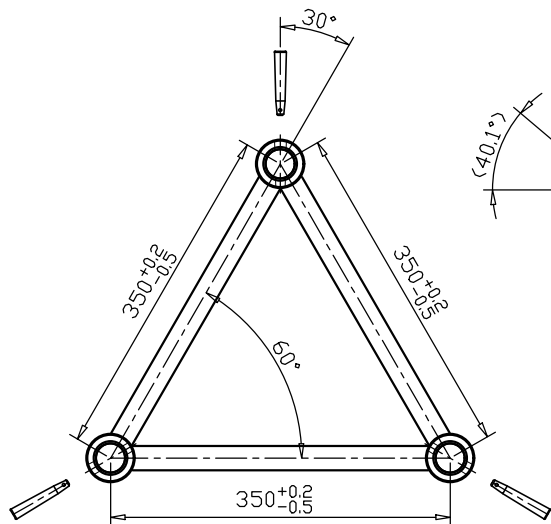
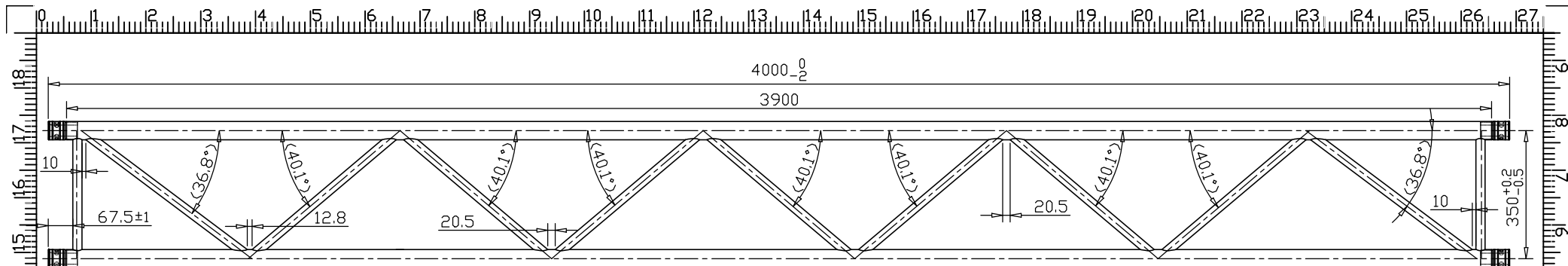

fitting	DMS-01-1	Steel	ZP	6
	DMS-01-4	S45C	ZP	6
	DMS-01-3	#2011	T6	3
05	∅25*3.0t*495mm	#6082	T6	21
04	∅25*3.0t*533.9mm	#6082	T6	6
03	∅25*3.0t*299.5mm	#6082	T6	6
02	∅50*3.0t*3900mm	#6082	T6	3
01	DMS-01-2CR	#6082	T6	6
NO.	SPEC.	MATERIAL	FIN.	QTY.

DRAWN	F43P	DRAW NO	F43400P	2D/3D	edition	1	
Specification	F43P-4.0M	DESIGN	Qiu Rongyi	DATE	17.06.08	CHECKED	APPROVED
Weight	22.45kgs/pcs	UNITS	mm	Proofread			
SURFACE	RAW	SCALE	1:15				

MARK	NAME	RETRIEVE	CONTENTS	DATE





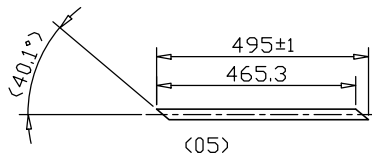
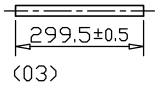
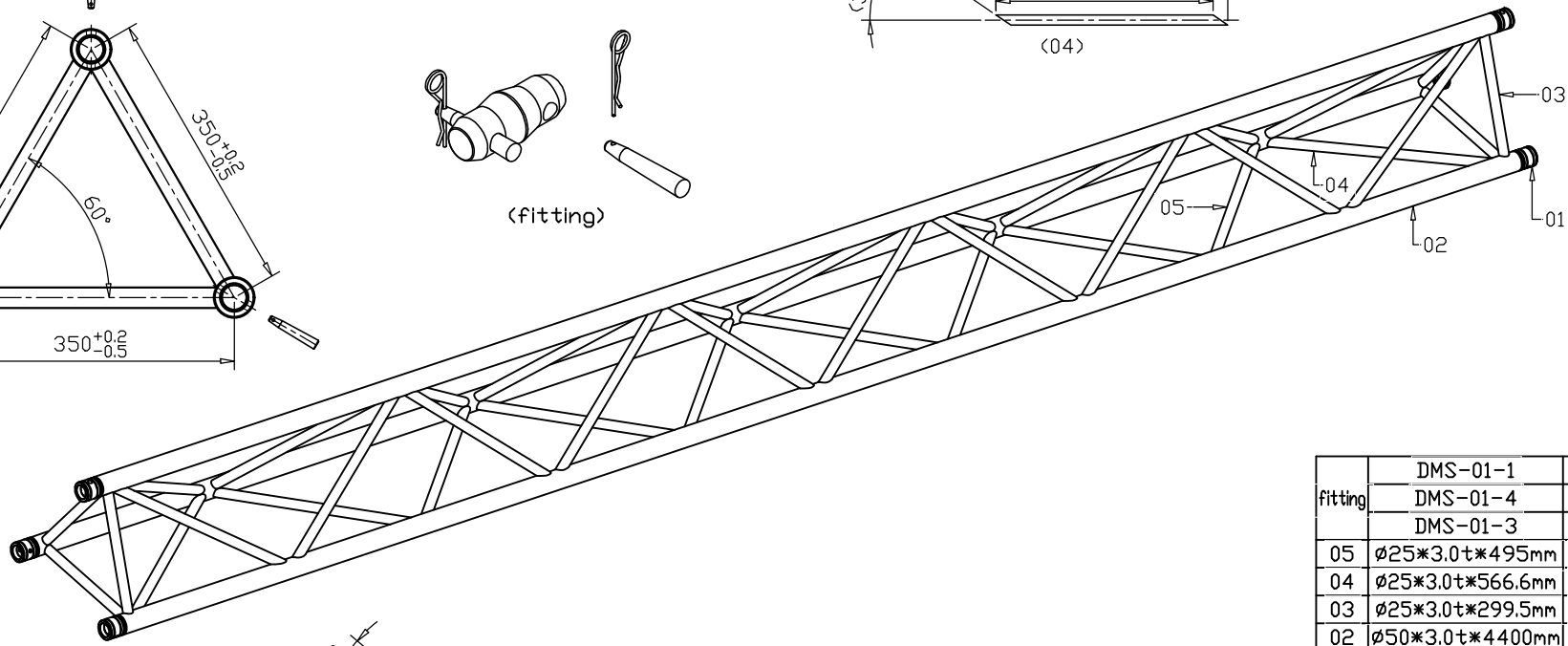
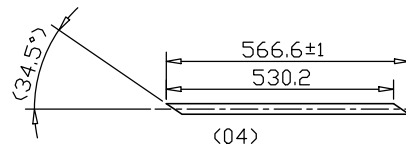
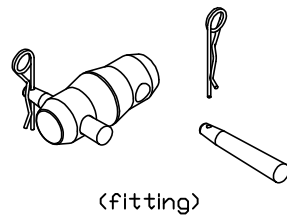
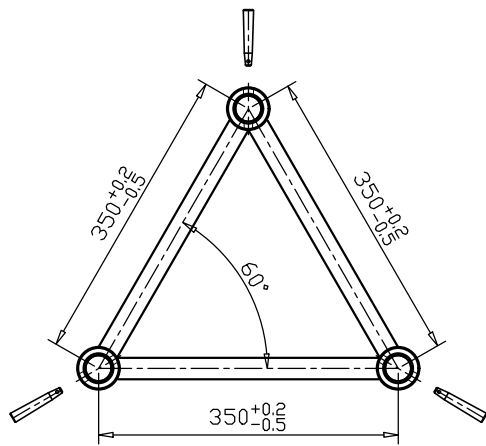
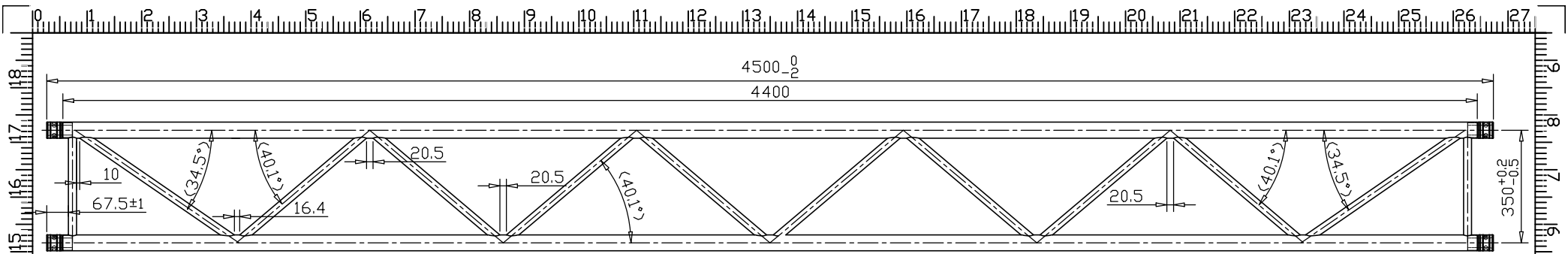

NO.	SPEC.	MATERIAL	FIN.	QTY.
fitting	DMS-01-1	Steel	ZP	6
	DMS-01-4	S45C	ZP	6
	DMS-01-3	#2011	T6	3
05	∅25*3.0t*495mm	#6082	T6	24
04	∅25*3.0t*566.6mm	#6082	T6	6
03	∅25*3.0t*299.5mm	#6082	T6	6
02	∅50*3.0t*4400mm	#6082	T6	3
01	DMS-01-2CR	#6082	T6	6

DRAWN	F43P	DRAW NO	F43450P	2D/3D	edition	1	
Specification	F43P-4.5M	DESIGN	Qiu Rongyi	DATE	17.06.08	CHECKED	APPROVED
Weight	25.0kgs/pcs	UNITS	mm	Proofread			
SURFACE	RAW	SCALE	1:17				

MARK	NAME	RETRIEVE	CONTENTS	DATE



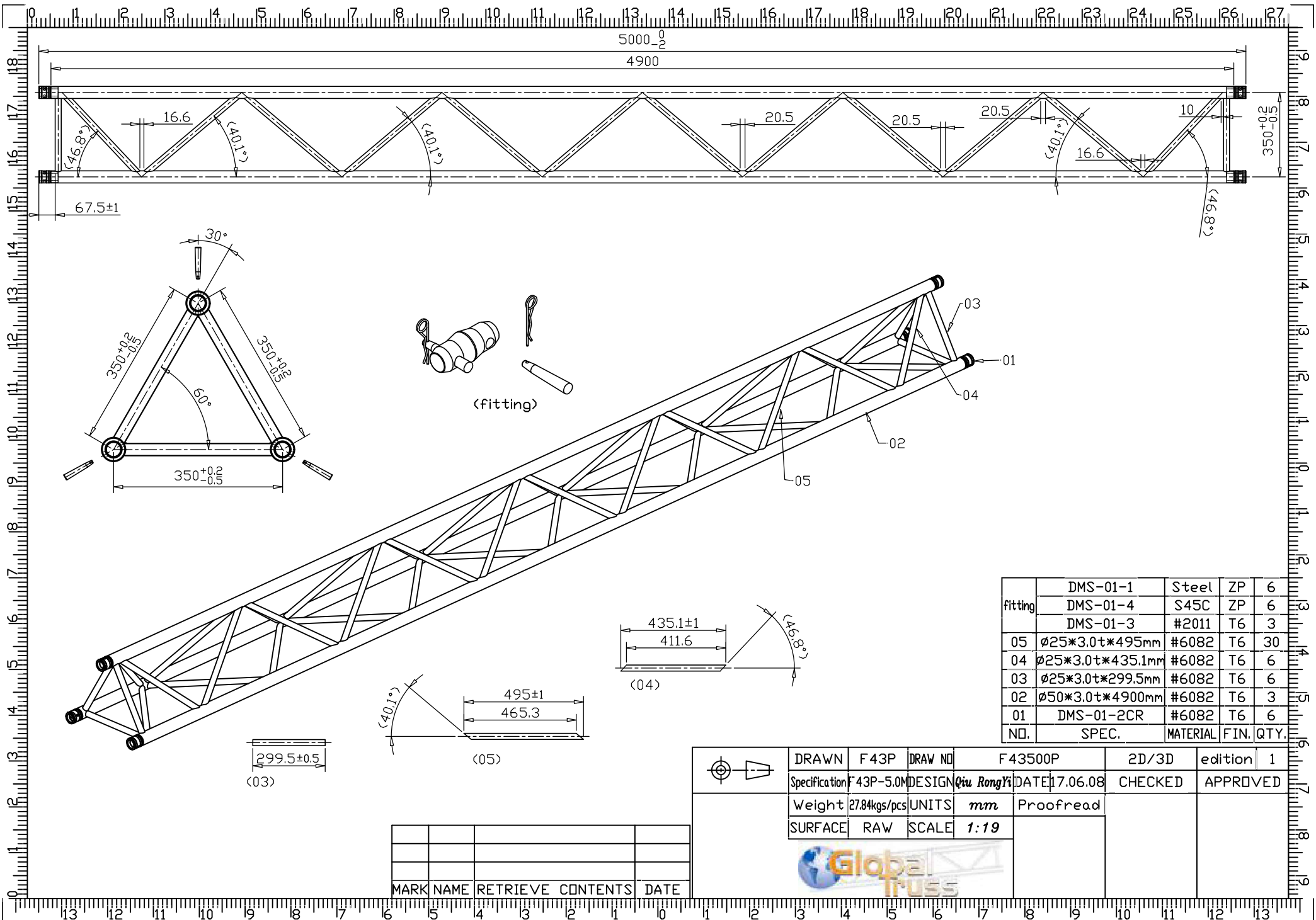

5000<sub>-2</sub>  
4900

350<sub>+0.2</sub>

16.6  
(46.8°)  
(40.1°)

20.5  
20.5  
20.5

16.6  
(40.1°)

10  
(46.8°)

67.5±1

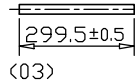
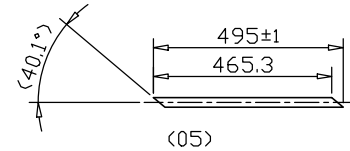
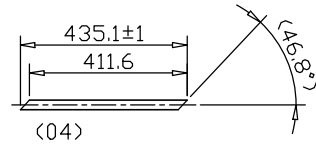
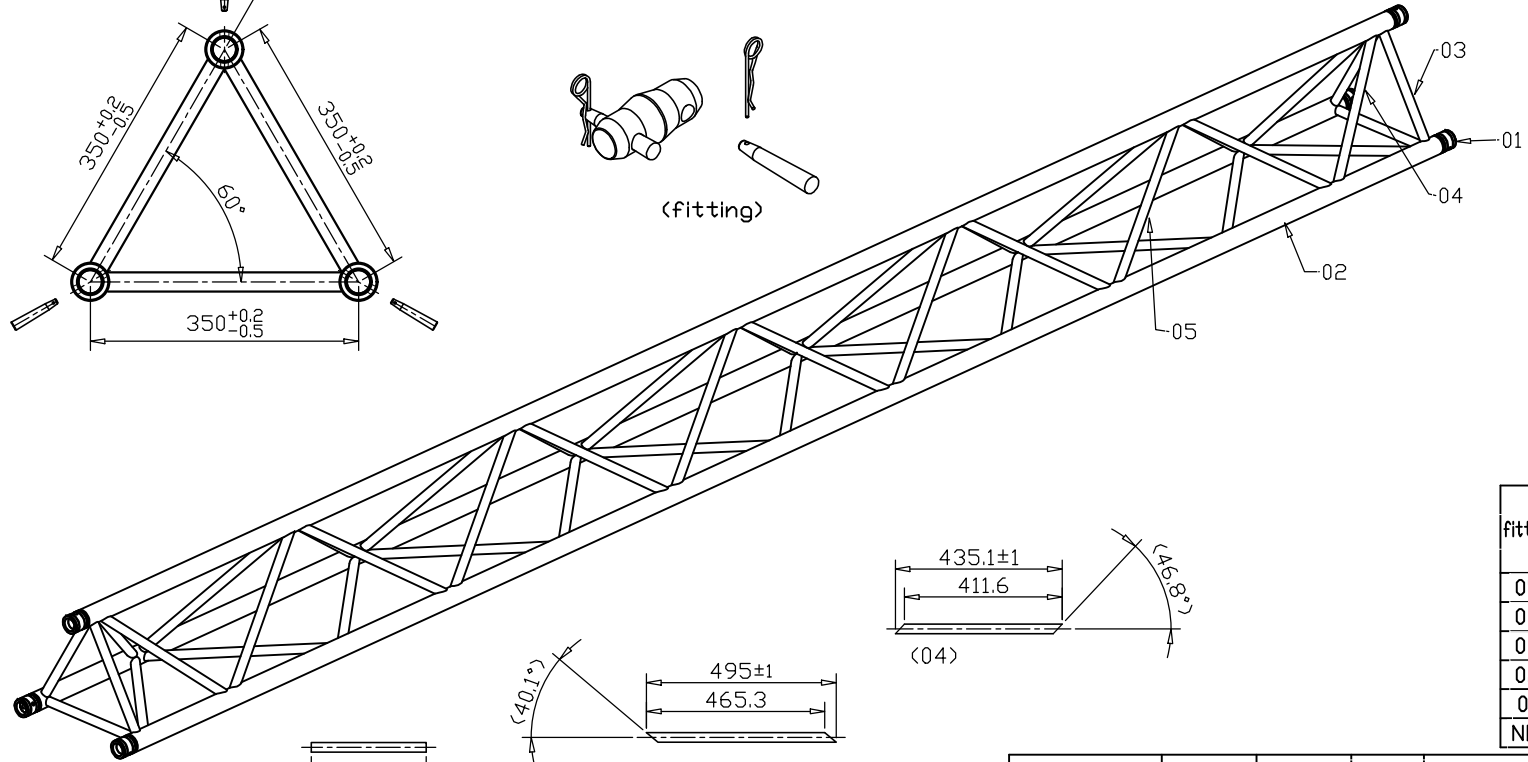
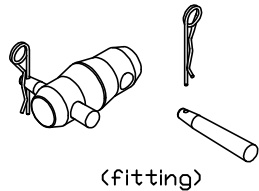
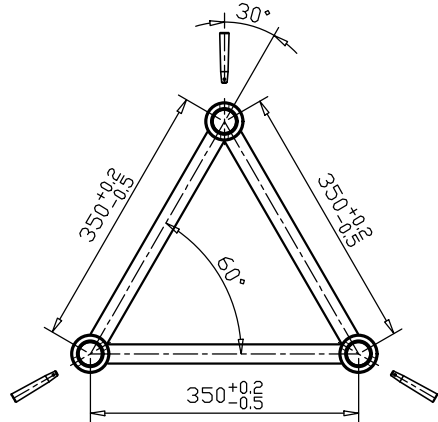

fitting	DMS-01-1	Steel	ZP	6
	DMS-01-4	S45C	ZP	6
	DMS-01-3	#2011	T6	3
05	∅25*3.0t*495mm	#6082	T6	30
04	∅25*3.0t*435.1mm	#6082	T6	6
03	∅25*3.0t*299.5mm	#6082	T6	6
02	∅50*3.0t*4900mm	#6082	T6	3
01	DMS-01-2CR	#6082	T6	6
NO.	SPEC.	MATERIAL	FIN.	QTY.

DRAWN	F43P	DRAW NO	F43500P	2D/3D	edition	1	
Specification	F43P-5.0M	DESIGN	Qiu Rongyi	DATE	17.06.08	CHECKED	APPROVED
Weight	27.84kgs/pcs	UNITS	mm	Proofread			
SURFACE	RAW	SCALE	1:19				



MARK	NAME	RETRIEVE	CONTENTS	DATE