



Büro für Tragwerksplanung und Ingenieurbau
vom Felde + Keppler GmbH & Co. KG

Lütticher Straße 10-12
52064 Aachen
www.vom-felde.de

Telefon: 0241 / 70 96 96
Telefax: 0241 / 70 96 46
buero@vom-felde.de

Structural Report

F45

17433

Date 05/11/2018

for the system by

Global Truss
Furong Industrial Area
Shajing Town

Baoan District Shenzhen China

Compiled by:

Aachen, 05th November 2018



This Structural Report includes pages

1 - 50

This Structural Report is set up exclusively for the company Global Truss.
Forwarding to third parties only with the author's approval.



TABLE OF CONTENTS

| | |
|---|----|
| 1 PRELIMINARY NOTES | 1 |
| 1.1 Basics | 1 |
| 1.2 Materials | 1 |
| 1.3 General remarks | 1 |
| 1.4 Geometry and loadings | 2 |
| 2 SYSTEM..... | 6 |
| 3 SECTION- AND MATERIAL PROPERTIES | 7 |
| 4 ALLOWABLE LOADING SINGLE COMPONENTS | 10 |
| 5 ALLOWABLE LOADING SINGLE SPAN GIRDER | 16 |
| 5.1 Center chords at bottom | 16 |
| 5.2 Outer chords + bracings uniformly distributed load (UDL)..... | 27 |
| 6 SUMMARY OF RESULTS | 42 |
| 6.1 Allowable loadings:..... | 42 |
| 6.2 Deflections at max. allowable loadings: | 48 |

ANNEXES

Drawings F45



1 PRELIMINARY NOTES

1.1 Basics

The currently applicable regulations and standards, in particular:

| | |
|---------------|--|
| DIN EN 1991-1 | Actions on structures (Eurocode 1) |
| DIN EN 13814 | Fairground and amusement park machinery and structures |
| DIN EN 13782 | Temporary Structures – Tents |
| DIN EN 1993-1 | Design of steel structures |
| DIN EN 1999-1 | Design of aluminium structures |

1.2 Materials

| | |
|-------|---------------------------------|
| Tubes | Aluminium EN AW-6082 T6 |
| Bolts | Güte mid. 8.8 (grade min. 10.9) |

1.3 General remarks

The truss system is part of a "modular construction system" with the different truss lengths

500mm, 1000mm, 1500mm, 2000mm, 2500mm, 3000mm, 3500mm, 4000mm, 4500mm and 5000mm.

The Trusses consist of 2 upper and 3 lower main chords (round tube 50 x 4mm), which are arranged in a quadratic shape. The center chord at the bottom is connected to the outer chords by cross tubes (round tube 50 x 4mm). The trusses also consist of welded diagonal bracings (round tube 25 x 3mm). The truss type F44-P is stiffened by diagonal bracings at the top and at both vertical sides.

The distance between system lines of the mainchords is 35 cm in vertical- and 35 cm in horizontal direction.

The trusses are connected at the 4 outer mainchords with couplers consisting of female fittings, connectors and bolts. The center chord of the bottom is not connected with couplers.

The loads are applied acc. chapter 1.4. The allowable loads are listed in tables (see chapter 6).

The verification of the single parts is done according the safety concept of EN 1990 with a partial safety factor of the loading side of 1.50 for payloads.

For applications which can be calculated on the basis of other codes, the partial safety factors can be adjusted (for example temporary structures acc. EN 13814, $\gamma_F = 1.35$ for payloads).

To use the resulting allowable loads with British Standard (BS) and ANSI, the allowable loads listed in tables have to be multiplied by 0.85



1.4 Geometry and loadings

The selfweight of the truss is approx. 15 kg/m

For the paylodas there are 2 loadcases taken into account:

LC 1) The load can be applied as a distributed load, as multiple point loads or as single point loads on the central bottom chord.

The allowable loading on the F45-truss is limited by two conditions:

- 1) First condition is the local load transfer from the central bottom chord to the bracing node.
- 2) Second condition is the global load transfer to the truss supports.

Resulting allowable loading see chapter 6

The following principle loadcases and loading situations are taken into account:

Structural system:

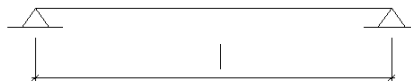

single span girder

Loading situations

1a) uniformly distributed load (UDL) on central bottom chord

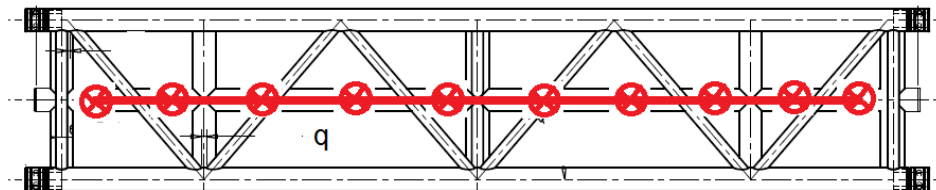

1b) multiple point load on central bottom chord with maximum point load of $P_i \leq 300 \text{ kg}$ and distances $\geq 50 \text{ cm}$ (equivalent to a distributed load of $\leq 600 \text{ kg/m}$). No restrictions concerning position on the central bottom chord but allowable loading in dependence of the span has to be respected, see chapter 6.

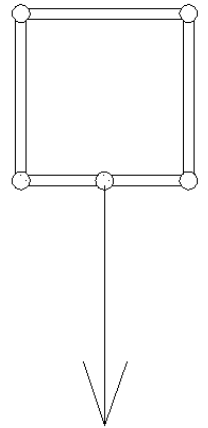
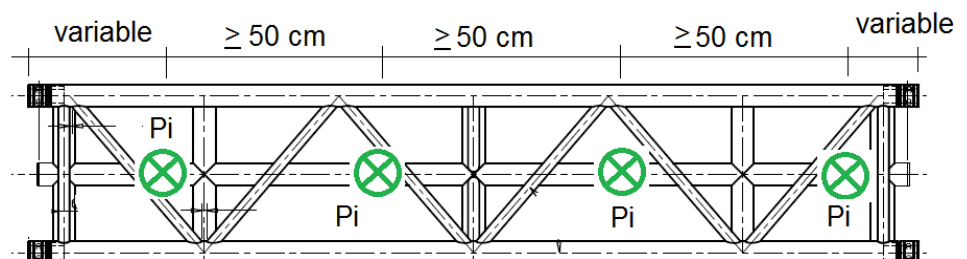



1c) Single point loads on central bottom chord

Single-load in 1/2 point

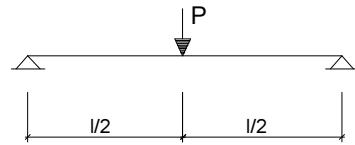

Single-load in 1/3 points

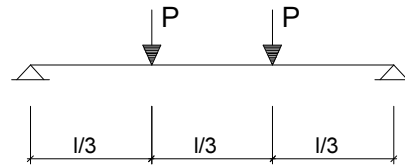

Single-load in 1/4 points

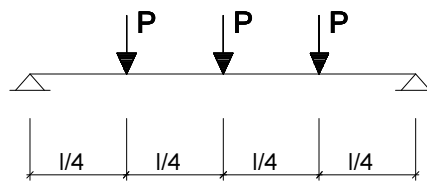

Single-load in 1/5 points

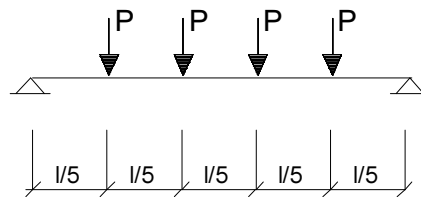



LC 2) The load can be applied as a distributed load or as single point loads on the side chords:

The following principle loadcases and loading situations are taken into account:

Structural system:

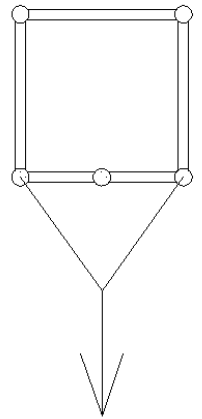
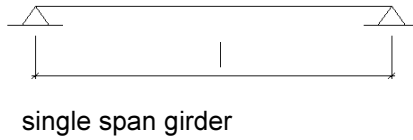

Loading situations

2a) uniformly distributed load (UDL) on side chords

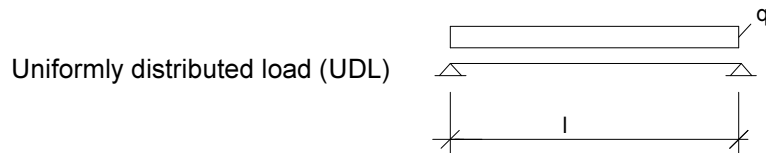

2b) Single point loads on central bottom chord

Single-load in 1/2 point

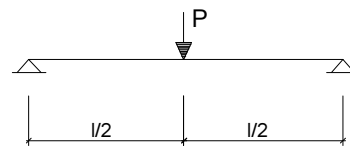

Single-load in 1/3 points

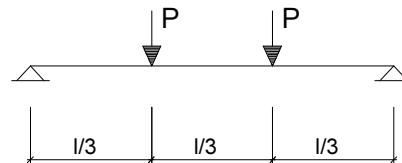

Single-load in 1/4 points

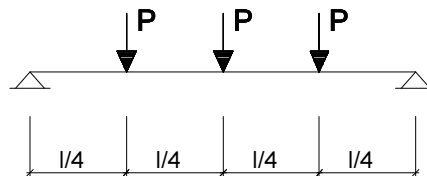

Single-load in 1/5 points

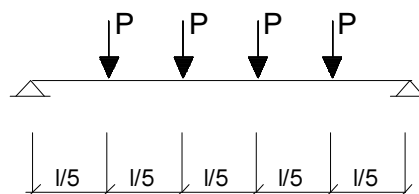



For the support or suspension there are the following possibilities:

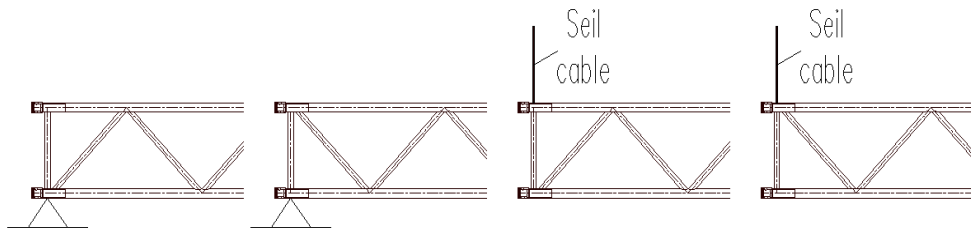

The trusses are connected at the 4 outer mainchords with couplers consisting of female fittings, connectors and bolts. The center chord of the bottom is not connected with couplers.

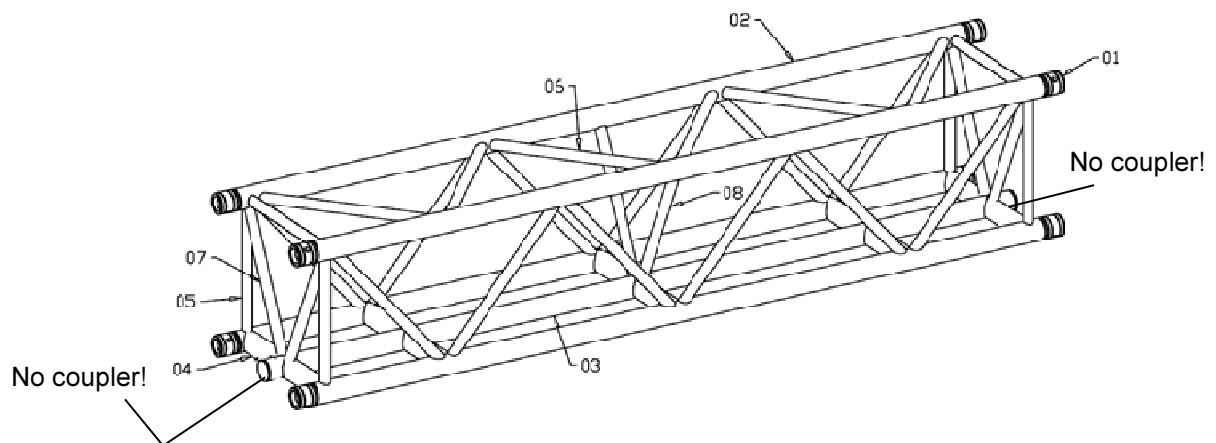



2 SYSTEM

Drawings F45

see annex



3 SECTION- AND MATERIAL PROPERTIES

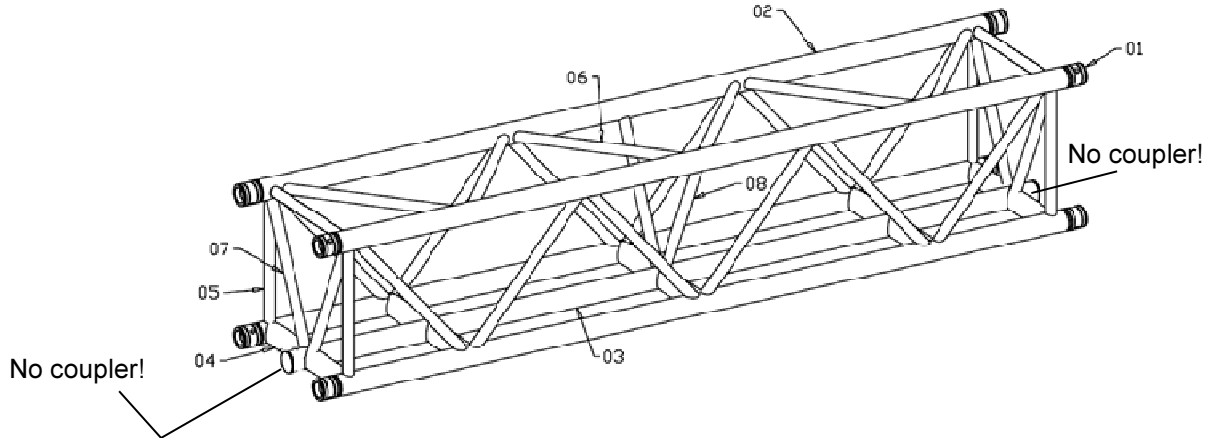

Querschnittswerte Rohre / properties Tubes

| | D [mm] | t [mm] | A [cm ²] | I [cm ⁴] | Wel [cm ³] | i [cm] |
|---------------------------------|-----------|-----------|-------------------------|-------------------------|---------------------------|-----------|
| Gurtrohre / main chords | 50,0 | 4 | 5,78 | 15,41 | 6,16 | 1,63 |
| vertikal Diagonalen / Bracing | 25 | 3 | 2,07 | 1,28 | 1,02 | 0,79 |
| horizontal Diagonalen / Bracing | 25 | 3 | 2,07 | 1,28 | 1,02 | 0,79 |

Geometrie Traverse / truss geometry

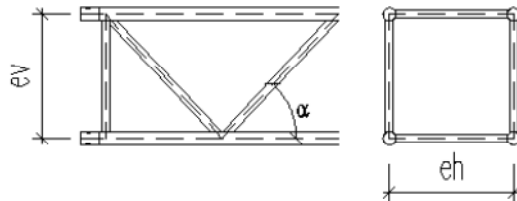

| | | | | |
|---------------------------|------------|----------|----|------|
| Achsabstand Gurtrohre | vertikal | ev | 35 | [cm] |
| distance axes main chords | horizontal | eh | 35 | [cm] |
| min. Neigung Diagonalen | vertikal | α | 41 | [°] |
| min. gradient bracing | horizontal | α | 41 | [°] |

Kennwerte Gesamttraverse / properties truss-Section

$$\begin{aligned}
 A &= 4 \times A_G &= & 23,12 \quad [\text{cm}^2] \\
 I_{yy} &= 4 \times I_G + 4 \times A_G \times (ev/2)^2 &= & 7142,77 \quad [\text{cm}^4] \\
 I_{zz} &= 4 \times I_G + 4 \times A_G \times (eh/2)^2 &= & 7142,77 \quad [\text{cm}^4] \\
 I_t &= \text{Näherung aus Erfahrungswerten} &= & 1666,38 \quad [\text{cm}^4] \\
 i_y &= (I_{yy}/A)^{1/2} &= & 17,58 \quad [\text{cm}] \\
 i_z &= (I_{zz}/A)^{1/2} &= & 17,58 \quad [\text{cm}]
 \end{aligned}$$

Index G : Querschnittseigenschaft Gurtrohr
section properties main chord



Material properties

| | | | |
|--|--------------------------|---|--------------------------|
| Gurtrohre + Diagonalen chords and bracing | EN AW 6082 T6 (AlMgSi1) | | |
| zulässige Spannungen nach EN-1999-1-1 / allowable stress acc. to EN-1999-1-1 | | | |
| Teilsicherheitsbeiwerte Material / partial safety factors material | | | |
| YM1= | 1,10 | Beulklasse / BC= | A |
| YM2= | 1,25 | | |
| 0,2%-Dehngrenze / 0,2%-Proof Strength | | Zugfestigkeit / ultimate tensile strength | |
| fo ≤5mm= | 250 [N/mm ²] | fu ≤5mm= | 290 [N/mm ²] |
| fo >5mm= | 260 [N/mm ²] | fu >5mm= | 310 [N/mm ²] |
| fo,haz= | 125 [N/mm ²] | fu,haz= | 185 [N/mm ²] |
| Festigkeit der Schweißnaht Strength of welding seams | | fw= | 190 [N/mm ²] |
| Faktor für die WEZ-Werte beim WIG-Schweißen: Factor for HAZ-values for TIG-welding: | | | 0,8 |

| | |
|----------------------|---------------|
| Bolzen / Bolt | 42 CrMo (8.8) |
|----------------------|---------------|

| | | | |
|---------------------------------------|--------------------------|---|--------------------------|
| Verbinder / Connector | EN AW 2011 T6 (AlCuBiPb) | | |
| 0,2%-Dehngrenze / 0,2%-Proof Strength | | Zugfestigkeit / ultimate tensile strength | |
| fo> | 230 [N/mm ²] | fu> | 310 [N/mm ²] |

| | | | |
|--|--------------------------|---|--------------------------|
| Hülse / Female fitting | EN AW 6082 T6 | | |
| zulässige Spannungen nach EN-1999-1-1 / allowable stress acc. to EN-1999-1-1 | | | |
| Teilsicherheitsbeiwerte Material / partial safety factors material | | | |
| YM1= | 1,10 | | |
| YM2= | 1,25 | | |
| 0,2%-Dehngrenze / 0,2%-Proof Strength | | Zugfestigkeit / ultimate tensile strength | |
| fo= | 250 [N/mm ²] | fu= | 290 [N/mm ²] |

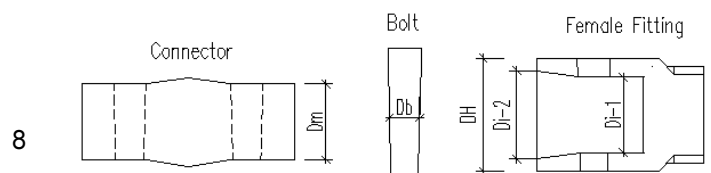



| Querschnitts- und Materialeigenschaften der Gurtrohre / Section- and material properties of the chord tubes | | | |
|---|--|--------|---|
| Material | E= | 70000 | [N/mm ²] |
| | fo= | 250,00 | [N/mm ²] |
| | fo/YM1= | 227,27 | [N/mm ²] |
| | fo,haz= | 125,00 | [N/mm ²] |
| | fu= | 290,00 | [N/mm ²] |
| | fu/YM2= | 232,00 | [N/mm ²] |
| | fu,haz= | 185,00 | [N/mm ²] |
| | fu,haz/YM2= | 148,00 | [N/mm ²] |
| Querschnitt cross section | D0= | 50,00 | [mm] |
| | A= | 5,78 | [cm ²] |
| | I= | 15,41 | [cm ⁴] |
| | i= | 1,63 | [cm] |
| Bestimmung der QS-Klasse Determination of section-class | β= | 10,61 | [-] |
| | ε= | 1,00 | [-] |
| | QS-Klasse= | 2 | |
| | | | 3 · (D0 / t) ^{0,5} nach 6.10 (250 / fo) ^{0,5} nach Kap. 6.1.4.4 acc. chapter 6.1.4.4 |
| Beiwerte Biegeknicken Coefficients for buckling | BC= | A | [-] |
| | α= | 0,20 | [-] |
| | λ0= | 0,10 | [-] |
| teff im Bereich der WEZ teff in heat affected zone | red-Faktor= | 0,8 | [-] (WIG πIG) |
| | Knotenpunkt mit 1 Diagonalen / node with 1 bracing | | |
| | D1= | 25,00 | [mm] |
| | U _{WEZ} = | 85,00 | [mm] D1 + 2 · 30 |
| | U _{Total} = | 157,08 | [mm] |
| | teff,o/t= | 0,68 | [-] [1 - (1 - red-Faktor · fo,haz / fo) · U _{WEZ} / U _{Total}] |
| | teff,u/t= | 0,74 | [-] [1 - (1 - red-Faktor · fu,haz / fu) · U _{WEZ} / U _{Total}] |
| | Knotenpunkt mit 2 Diagonalen / node with 2 bracing | | |
| | D1= | 25,00 | [mm] |
| | D2= | 25,00 | [mm] |
| | U _{WEZ} = | 124,27 | [mm] π / 4 · D0 + D1 / 2 + D2 / 2 + 2 · 30 |
| | U _{Total} = | 157,08 | [mm] |
| | teff,o / t= | 0,53 | [-] [1 - (1 - red-Faktor · fo,haz / fo) · U _{WEZ} / U _{Total}] |
| | teff,u / t= | 0,61 | [-] [1 - (1 - red-Faktor · fu,haz / fu) · U _{WEZ} / U _{Total}] |

| Querschnitts- und Materialeigenschaften der Diagonalen / Section- and material properties of the bracing | | | |
|--|---------|--------|----------------------|
| Material | E= | 70000 | [N/mm ²] |
| | fo= | 250,00 | [N/mm ²] |
| | fo/YM1= | 227,27 | [N/mm ²] |
| | BC= | A | [-] |
| | α= | 0,20 | [-] |
| | λ0= | 0,1 | [-] |
| Querschnitt / cross section | D0= | 25 | [mm] |
| | A= | 2,07 | [cm ²] |
| | I= | 1,28 | [cm ⁴] |
| | i= | 0,79 | [cm] |



4 ALLOWABLE LOADING SINGLE COMPONENTS

Outer chords at top and bottom

| | | | |
|---|--------------|----------------------|---|
| Gurtrohr im Bereich der WEZ an der Kupplung main chord in heat affected zone at coupler | | | |
| $NR_d = A \times 0,8^* \times f_{u,haz} / Y_{M2} =$ | 68,44 | [kN] | *(WIG _{TIG}) örtliche Schweißnaht nach Kap. 6.2.9.3 (1) local welding seam acc. chapter 6.2.9.3 (1) |
| Gurtrohr im Bereich der WEZ main chord in heat affected zone Knotenpunkt mit 1 Diagonalen / node with 1 bracing | | | |
| $NR_d = A_{eff} \times f_o / Y_{M1} =$ (mit $A_{eff} = t_{eff,o} / t \times A$) | 88,72 | [kN] | örtliche Schweißnaht nach Kap. 6.2.9.3 (2) local welding seam acc. Chapter 6.2.9.3 (2) |
| Knotenpunkt mit 2 Diagonalen / node with 2 bracing | | | |
| $NR_d = A_{eff} \times f_o / Y_{M1} =$ (mit $A_{eff} = t_{eff,o} / t \times A$) | 69,01 | [kN] | örtliche Schweißnaht nach Kap. 6.2.9.3 (2) local welding seam acc. Chapter 6.2.9.3 (2) |
| Knicken Gurtrohr zw. Knoten mit 1 Diagonale in der Mitte buckling main chord between nodes with 1 bracing in the middle | | | |
| $sk =$ | 80,00 | [cm] | |
| $N_{cr} =$ | 166,30 | [kN] | |
| $\lambda^* =$ | 0,93 | [-] | |
| $\phi =$ | 1,02 | [-] | |
| $X =$ | 0,70 | [-] | |
| $A_1 =$ | 3,74 | [cm ²] | nach Tab. 6.5 |
| $\kappa =$ | 0,84 | [-] | acc. table 6.5 |
| $NR_d = X \times \kappa \times A_{eff} \times f_o / Y_{M1} =$ (mit $A_{eff} = A$ für QSK 1,2 und 3, s. EN 1999-1-1 Kap. 6.3.1.1) | 77,82 | [kN] | nach Gl. 6.49 acc. equation 6.49 |
| Knicken Gurtrohr zw. Knoten ohne Diagonale in der Mitte buckling main chord between nodes without bracing in the middle | | | |
| $sk =$ | 80,00 | [cm] | |
| $N_{cr} =$ | 166,30 | [kN] | |
| $\lambda^* =$ | 0,93 | [-] | |
| $\phi =$ | 1,02 | [-] | |
| $X =$ | 0,70 | [-] | |
| $NR_d = X \times A \times f_o / Y_{M1} =$ | 92,12 | [kN] | nach Gl. 6.49 acc. equation 6.49 |
| Schweißnaht zwischen Gurtrohr und Hülse welding seam between chord and female conical coupler | | | |
| $f_w =$ | 190,00 | [N/mm ²] | |
| $Y_{mw} =$ | 1,25 | [-] | |
| $NR_d = A \times f_w / Y_{M1} =$ | 87,86 | [kN] | nach Gl. 8.29 acc. equation 8.29 |

relevant for main chord tubes: **$NR_d = 68,44$ kN**



Bending of the center chord at the bottom and of the cross tubes:

| Lokale Biegung unteres inneres Gurtrohr Knotenpunkt mit Querrohr | | | | |
|--|---|--------------|--------------------|-------------------------------------|
| Local bending of lower inner chord with lateral tube | | | | |
| örtliche Schweißnaht nach Kap. 6.2.9.3 (2) | | | | |
| local welding seam acc. Chapter 6.2.9.3 (2) | | | | |
| | α = | 0,55 | [-] | nach Tab. 6.4 |
| Nebenrechnung QS-Kl. 3 | D= | 50,0 | [mm] | |
| Auxiliary calculation for class 3 | red-Faktor= | 0,8 | [-] | (WIG TIG) |
| | $\rho_{0,haz}$ = | 0,5 | [-] | $f_{0,haz} / f_0$ |
| | $t_{0,eff}$ = | 1,60 | [mm] | $t_{eff,o} / t \cdot t$ |
| | $W_{el,haz} = \pi \times R^2 \times t_{0,eff}$ = | 2,66 | [cm ²] | mit $R = D / 2 - t / 2$ |
| | W_{el} = | 6,16 | [cm ²] | |
| | $W_{pl,haz} = 4 \times R^2 \times t_{0,eff}$ = | 3,39 | [cm ²] | mit $R = D / 2 - t / 2$ |
| | β_3 = | 18 | | nach KaI nach Kap. 6.1.4.4 |
| | β_2 = | 13 | | nach KaI nach Kap. 6.1.4.4 |
| | $\alpha_{,3w}$ = | 0,61 | [-] | |
| | $MoRd = \alpha \cdot W_{el} \cdot f_0 / y_{M1}$ = | 76,95 | [kNcm] | nach Gl. 6.24 acc. equation 6.24 |

Bracing

| Diagonale im Bereich der WEZ | | | | |
|---|--|---------------|----------------------|---|
| bracing in heat affected zone | | | | |
| | $NRd = A \times 0,8 \times f_{u,haz} / Y_{M2}$ = | 24,55 | [kN] | *(WIG TIG) örtliche Schweißnaht nach Kap. 6.2.9.3 (1) local welding seam acc. chapter 6.2.9.3 (1) |
| Knicken Diagonale | s_k = | 45,00 | [cm] | |
| buckling bracing | N_{cr} = | 43,59 | [kN] | |
| | λ^* = | 1,09 | [-] | |
| | ϕ = | 1,19 | [-] | |
| | X = | 0,60 | [-] | |
| | $NRd = X \times A_G \times f_0 / Y_{M1}$ = | 28,07 | [kN] | nach Gl. 6.49 acc. equation 6.49 |
| Schweißnaht zwischen Diagonale und Gurtrohr | | | | |
| welding seam between chord and female conical coupler | | | | |
| | f_w = | 190,00 | [N/mm ²] | |
| | Y_{mw} = | 1,25 | [-] | |
| | $NRd = A \times f_w / Y_{M1}$ = | 31,52 | [kN] | nach Gl. 8.29 acc. equation 8.29 |

relevant for bracing tubes:

$$NR_{dD} = 24,55 \text{ kN}$$



Allowable normal force at coupler:

| Bolzen / Bolt | | |
|--|--|-----------------------------|
| Material / material (8.8) | fy,bk= | 64,00 [kN/cm ²] |
| | fu,bk= | 80,00 [kN/cm ²] |
| Geometrie / geometry | Db= | 1,08 [cm] |
| | Ab= | 0,91 [cm ²] |
| zul Normalkraft aus Abscheren n. EN 1999-1-1 allow able loading due to shearing acc. to EN 1999-1-1 | | |
| | $NRd = 2 \times 0,60 \times Ab \times f_{ub,k} / 1,25 =$ | 69,71 [kN] |
| Verbinder / Connector | | |
| Material / material | EN AW 2011 (AlCuBiPb F37) | |
| Geometrie / geometry | Dm= | 29 [mm] |
| <u>Lochleibung in Verbinder</u> Bearing stress in connector | fu / YM2= | 248,00 [N/mm ²] |
| | do= | 11 [mm] |
| | t= | 29 [mm] |
| | e1= | 17,1 [mm] |
| | $\alpha_b =$ | 0,52 [-] |
| | e2= | 14,5 [mm] |
| | k1= | 1,99090909 [-] |
| | $NRd = k1 \times \alpha_b \times fu \times d \times t / YM2 =$ | 81,62 [kN] |
| Nachweis Restquerschnitt auf Zug Remaining section under tension | | |
| | $NRd = 0,9 \times A_{net} \times fu / YM2 =$ | 76,23 [kN] |
| Hülse / Female Fitting | | |
| Geometrie / geometry | DH= | 50 [mm] |
| | Di-1= | 29 [mm] |
| | Di-2= | 35 [mm] |
| | Di-m= | 32 [mm] |
| <u>Lochleibung in Hülse</u> Bearing stress in female fitting | fu / YM2= | 232 [N/mm ²] |
| | do= | 13 [mm] |
| | t = DH - Di-m= | 18 [mm] |
| | e1> | 23 [mm] |
| | $\alpha_b =$ | 0,59 |
| | e2> | 20 [mm] |
| | k1= | 2,5 |
| | $NRd = k1 \times \alpha_b \times fu \times d \times t / YM2 =$ | 80,04 [kN] |

The allowable normal force of the coupler is not relevant compared to the allowable normal force of the tube ($NRd_G = 68,44 \text{ kN} < 69,71 \text{ kN}$).



Interaction bending and normal force at coupler of the outer chords

Verification of interaction bending and normal force at coupler

$$\Rightarrow (Nsd_G / NRd_G)^{1,3} + (Msd_G / MRd_G) < 1,0$$

mit $Nsd_G = Nsd / 4 + Msd / (2 \cdot 0,35 \text{ m})$

und $Msd_G = 0,25 \cdot Qsd \cdot 8,0 \text{ cm} = 2,0 \text{ cm} \cdot Qsd$

$\Rightarrow a = \text{factor for cantilever at the coupler} = 2,0 \text{ cm}$

Nsd, Msd und Qsd : global internal forces in the truss (in kN resp. kNm)

The global internal forces include the following safety factors acc. Eurocode:

selfweight of the truss: $yF = 1,35$

Net load on the truss: $yF = 1,50$

NRd_G = allowable loading of the chord in the heat affected zone (see following table):

| | | | |
|--|--------------|------|---|
| Gurtrohr im Bereich der WEZ an der Kupplung main chord in heat affected zone at coupler | | | |
| $NRd = A \times 0,8^* \times fu, haz / YM2 =$ | 68,44 | [kN] | *(WIG TIG) örtliche Schweißnaht nach Kap. 6.2.9.3 (1) local welding seam acc. chapter 6.2.9.3 (1) |

$MRd_G = MuRd$ (see following table):

| | | | |
|---|--------------|--------------------|--|
| Lokale Biegung Gurtrohr Knotenpunkt vollst. in WEZ Local bending of chord | | | |
| örtliche Schweißnaht nach Kap. 6.2.9.3 (1) local welding seam acc. Chapter 6.2.9.3 (1) | | | |
| D= | 50 | [mm] | |
| red-Faktor= | 0,8 | [-] | (WIG TIG) |
| $\rho_{0, haz} =$ | 0,64 | [-] | $fu, haz / fu$ |
| $t_{u, eff} =$ | 2,04 | [mm] | red-Faktor $\cdot \rho_{u, haz} \cdot t$ |
| $W_{net} = \pi \times R^2 \times t_{u, eff} =$ | 3,39 | [cm ³] | mit $R = D / 2 - t / 2$ |
| $MuRd = W_{net} \cdot fu / yM2 =$ | 78,71 | [kNcm] | nach Gl. 6.24 acc. equation 6.24 |



The following 4 cases are taken into account.

1. Verification of the center chords at the bottom at UDL-loads or multiple single point loads (LC 1a and 1b)

The loads at center chord at the bottom are loaded at the worst points with multiple single point loads at a distance of 50 cm between each load.

2. Verification of the center chord at the bottom with single point loads (LC 1c)

No requirements for position of coupler (see below).

3. Verification of the outer chords with uniformly distributed load (UDL) (LC 2a)

The coupler is always located at the theoretically worst point. This results from the following extremum-calculation:

Note: For the determination of the worst position of the coupler, the exponent 1,3, for the relation of actual load to the allowable load is not taken into account with sufficient accuracy.

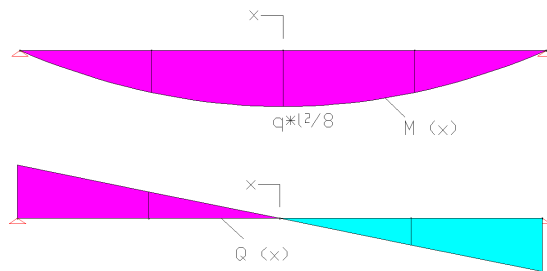

$$M_{sd}(x) = q_{sd} \cdot L^2 / 8 - q_{sd} \cdot x^2 / 2$$

$$Q_{sd}(x) = q_{sd} \cdot x$$

$$NR_{dG} = 68,44 \text{ kN}$$

$$MR_{dG} = 78,71 \text{ kNcm}$$

$$\text{M-Q Interaction} \quad M_{sd}(x) / (2 \cdot 0,35 \cdot 68,44) + Q_{sd}(x) \cdot 2,0 / 78,71$$

$$\text{Extreme value:} \quad d/dx \sigma(x) = 0$$

$$\Rightarrow x = 2 \cdot 0,35 \cdot 68,44 \cdot 2,0 / 78,71 = 1,217 \text{ m}$$

(from middle of span)

4. Verification of the side chords with single point loads (LC 2b)

No requirements for position of coupler (Distance between load and coupler is $e \geq 9,5 \text{ cm}$, see below)

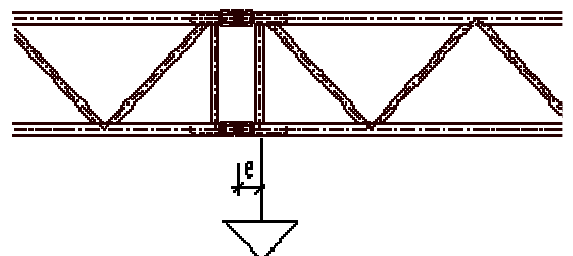



Summary

Following points are relevant for the determination of the allowable loads:

1. Allowable bending moment of the center chord at the bottom and the cross tubes (MR_{dG}) $\Rightarrow MR_{dG} = 76,95 \text{ kNm}$
2. Allowable normal force in main chord (NR_{dG})
Main chord in heat affected zone at coupler is relevant $\Rightarrow NR_{dG} = 68,44 \text{ kN}$
3. Global shear force in truss (Q)
Allowable normal force in diagonals at nodes is relevant $\Rightarrow NR_{dB} = 24,55 \text{ kN}$

zul shear force from $QR_d / (2 \cdot \sin 41^\circ) < 0,9 \cdot NR_{dB}$
* 10% reduction because of minor stresses
 $\Rightarrow \text{allow. } QR_d = 0,9 \cdot 24,55 \cdot 2 \cdot \sin 41^\circ \Rightarrow QR_d = 28,99 \text{ kN}$
4. Interaction bending and normal force at coupler \Rightarrow see page 13



5 ALLOWABLE LOADING SINGLE SPAN GIRDER

5.1 Center chords at bottom

Systems [cm]:

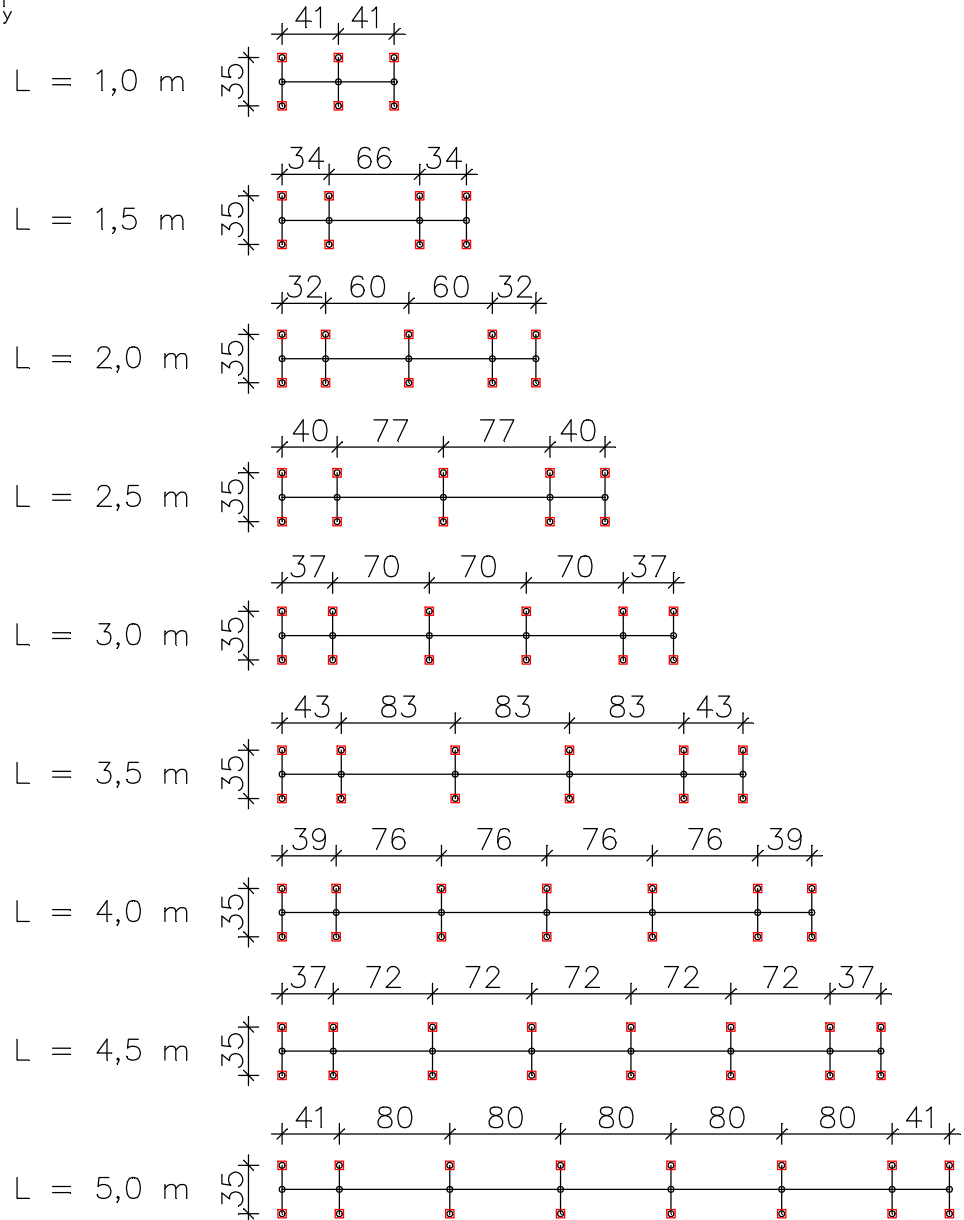

| | | |
|---------------|--|--|
| Loadings: | Multiple point loads at a distance of 50 cm Single point load (CPL or at 1/3-, 1/4- or 1/5-pts) | Pi = 3,0 kN see following pages Pi = 5,0 kN |
| Calculation | | see following pages |
| Verification: | Multiple point loads max M _{Ed} = 1,5 · 45 kNcm = 67,5 kNcm | < MR _d = 76,95 kNcm |
| | Single point load max M _{Ed} = 1,5 · 5 · 35 / 4 = 66 kNcm | < MR _d = 76,95 kNcm |



5.2 Outer chords + bracing uniformly distributed load (UDL)

System:

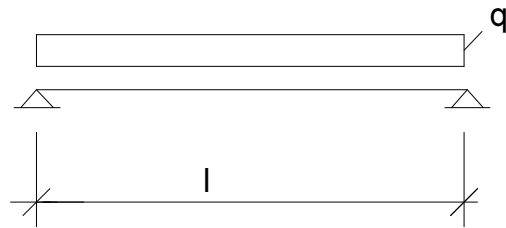

Loading

$$q_{sd} = p_{sd} + g_{sd}$$

(Net load + selfweight, incl. safety factors)

Normal force in chords:

$$\begin{aligned} NR_d &\geq q_{sd} \cdot L^2 / 8 / (n \cdot b) \\ \Rightarrow q_{sd} &\leq NR_d \cdot (n \cdot b) \cdot 8 / L^2 \\ \Rightarrow \text{zul } p &= (NR_d \cdot (n \cdot b) \cdot 8 / L^2 - g_{sd}) / \gamma_F \end{aligned}$$

Normal force in bracing:

$$\begin{aligned} QR_d &\geq q_{sd} \cdot L / 2 \\ \Rightarrow q_{sd} &\leq QR_d \cdot 2 / L \\ \Rightarrow \text{zul } p &= (QR_d \cdot 2 / L - g_{sd}) / \gamma_F \end{aligned}$$

Interaction at coupler:

Verification of interaction bending and normal force at coupler by an iterative method.

$$\Rightarrow (N_{sdG} / NR_{dG})^{1,3} + (M_{sdG} / MR_{dG}) < 1,0$$

The coupler is located at $e = 1,217$ m from the middle of the span (theoretically worst point, see extremum-calculation in chapter 4)

Center chord at bottom:

$$\text{zul } p \leq 6,0 \text{ kN/m}$$

Limit of deflection:

$$\begin{aligned} \text{Limit of deflection max. } u &= L / f \\ \Rightarrow \text{zul } p &= (L / f) / (5/384 \cdot L^4 / E / I_{yy}) - g \end{aligned}$$

3 different limitations are taken into account:

$$\begin{aligned} \text{max. } u &= L / 100 \\ \text{max. } u &= L / 200 \\ \text{max. } u &= L / 300 \end{aligned}$$

Loading tables:

see following pages



Uniformly distributed load UDL

| | zulässige Belastung in Abhängigkeit von allowable load as a function of | | | |
|-------|--|--------------|------------------------|------------------|
| | NRd | QRd | Interaction at coupler | Deflection L/100 |
| L [m] | zul q [kN/m] | zul q [kN/m] | zul q [kN/m] | zul q [kN/m] |
| 4,00 | 15,84 | 9,53 | 12,60 | 59,85 |
| 5,00 | 10,09 | 7,60 | 8,75 | 30,57 |
| 6,00 | 6,96 | 6,31 | 6,31 | 17,63 |
| 7,00 | 5,08 | 5,39 | 4,73 | 11,05 |
| 8,00 | 3,86 | 4,70 | 3,65 | 7,35 |
| 9,00 | 3,02 | 4,16 | 2,89 | 5,12 |
| 10,00 | 2,42 | 3,73 | 2,34 | 3,69 |
| 11,00 | 1,98 | 3,38 | 1,92 | 2,74 |
| 12,00 | 1,64 | 3,09 | 1,60 | 2,07 |
| 13,00 | 1,38 | 2,84 | 1,35 | 1,60 |
| 14,00 | 1,17 | 2,63 | 1,15 | 1,25 |
| 15,00 | 1,00 | 2,44 | 0,99 | 0,99 |
| 16,00 | 0,86 | 2,28 | 0,85 | 0,79 |
| 17,00 | 0,75 | 2,14 | 0,74 | 0,63 |
| 18,00 | 0,66 | 2,01 | 0,65 | 0,51 |
| 19,00 | 0,57 | 1,90 | 0,57 | 0,41 |
| 20,00 | 0,51 | 1,80 | 0,50 | 0,33 |
| 21,00 | 0,45 | 1,71 | 0,44 | 0,27 |
| 22,00 | 0,39 | 1,62 | 0,39 | 0,21 |
| 23,00 | 0,35 | 1,55 | 0,35 | 0,17 |
| 24,00 | 0,31 | 1,48 | 0,31 | 0,13 |

Note: If the load is applied at the center bottom chord (LC1) it has to be $\leq 6,0$ kN/m

Uniformly distributed load UDL

| | zulässige Belastung in Abhängigkeit von allowable load as a function of | | | |
|-------|--|--------------|------------------------|------------------|
| | NRd | QRd | Interaction at coupler | Deflection L/200 |
| L [m] | zul q [kN/m] | zul q [kN/m] | zul q [kN/m] | zul q [kN/m] |
| 4,00 | 15,84 | 9,53 | 12,60 | 29,85 |
| 5,00 | 10,09 | 7,60 | 8,75 | 15,21 |
| 6,00 | 6,96 | 6,31 | 6,31 | 8,74 |
| 7,00 | 5,08 | 5,39 | 4,73 | 5,45 |
| 8,00 | 3,86 | 4,70 | 3,65 | 3,60 |
| 9,00 | 3,02 | 4,16 | 2,89 | 2,49 |
| 10,00 | 2,42 | 3,73 | 2,34 | 1,77 |
| 11,00 | 1,98 | 3,38 | 1,92 | 1,29 |
| 12,00 | 1,64 | 3,09 | 1,60 | 0,96 |
| 13,00 | 1,38 | 2,84 | 1,35 | 0,73 |
| 14,00 | 1,17 | 2,63 | 1,15 | 0,55 |
| 15,00 | 1,00 | 2,44 | 0,99 | 0,42 |
| 16,00 | 0,86 | 2,28 | 0,85 | 0,32 |
| 17,00 | 0,75 | 2,14 | 0,74 | 0,24 |
| 18,00 | 0,66 | 2,01 | 0,65 | 0,18 |
| 19,00 | 0,57 | 1,90 | 0,57 | 0,13 |
| 20,00 | 0,51 | 1,80 | 0,50 | 0,09 |
| 21,00 | 0,45 | 1,71 | 0,44 | 0,06 |
| 22,00 | 0,39 | 1,62 | 0,39 | 0,03 |

Note: If the load is applied at the center bottom chord (LC1) it has to be $\leq 6,0$ kN/m



Uniformly distributed load UDL

| | zulässige Belastung in Abhängigkeit von allowable load as a function of | | | |
|-------|--|--------------|------------------------|------------------|
| | NRd | QRd | Interaction at coupler | Deflection L/300 |
| L [m] | zul q [kN/m] | zul q [kN/m] | zul q [kN/m] | zul q [kN/m] |
| 4,00 | 15,84 | 9,53 | 12,60 | 19,85 |
| 5,00 | 10,09 | 7,60 | 8,75 | 10,09 |
| 6,00 | 6,96 | 6,31 | 6,31 | 5,78 |
| 7,00 | 5,08 | 5,39 | 4,73 | 3,58 |
| 8,00 | 3,86 | 4,70 | 3,65 | 2,35 |
| 9,00 | 3,02 | 4,16 | 2,89 | 1,61 |
| 10,00 | 2,42 | 3,73 | 2,34 | 1,13 |
| 11,00 | 1,98 | 3,38 | 1,92 | 0,81 |
| 12,00 | 1,64 | 3,09 | 1,60 | 0,59 |
| 13,00 | 1,38 | 2,84 | 1,35 | 0,43 |
| 14,00 | 1,17 | 2,63 | 1,15 | 0,32 |
| 15,00 | 1,00 | 2,44 | 0,99 | 0,23 |
| 16,00 | 0,86 | 2,28 | 0,85 | 0,16 |
| 17,00 | 0,75 | 2,14 | 0,74 | 0,11 |
| 18,00 | 0,66 | 2,01 | 0,65 | 0,07 |
| 19,00 | 0,57 | 1,90 | 0,57 | 0,04 |
| 20,00 | 0,51 | 1,80 | 0,50 | 0,01 |

Note: If the load is applied at the center bottom chord (LC1) it has to be $\leq 6,0$ kN/m



5.3 Outer chords + bracing single point load at 1/2-point

System:

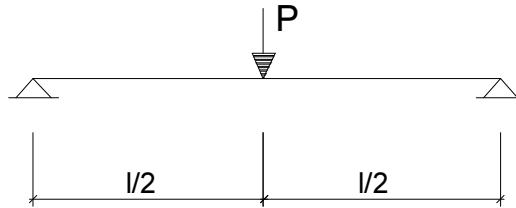

Loading

Psd + gsd

(Net load + selfweight, incl. safety factors)

Normal force in chords:

$$\begin{aligned}NRd &\geq (Psd \cdot L / 4 + gsd \cdot L^2 / 8) / (n \cdot b) \\ \Rightarrow Psd &\leq [NRd \cdot (n \cdot b) - gsd \cdot L^2 / 8] \cdot 4 / L \\ \Rightarrow \text{zul } P &= [NRd \cdot (n \cdot b) - gsd \cdot L^2 / 8] \cdot 4 / L / yF\end{aligned}$$

Normal force in bracing:

$$\begin{aligned}QRd &\geq Psd / 2 + gsd \cdot L / 2 \\ \Rightarrow Psd &\leq (QRd - gsd \cdot L / 2) \cdot 2 \\ \Rightarrow \text{zul } P &= (QRd - gsd \cdot L / 2) \cdot 2 / yF\end{aligned}$$

Interaction at coupler:

Verification of interaction bending and normal force at coupler by an iterative method.

$$\Rightarrow (Nsd_G / NRd_G)^{1,3} + (Msd_G / MRd_G) < 1,0$$

The coupler is located at $e = 0,095$ m from the coupler

Center chord at bottom:

$$\text{zul } P \leq 5,0 \text{ kN}$$

Limit of deflection:

$$\begin{aligned}\text{Limit of deflection max. } u &= L / f \\ \Rightarrow \text{zul } P &= [L / f - g \cdot (5/384 \cdot L^4 / E / I_{yy})] / (L^3/48 / E / I_{yy})\end{aligned}$$

3 different limitations are taken into account:

$$\text{max. } u = L / 100$$

$$\text{max. } u = L / 200$$

$$\text{max. } u = L / 300$$

Loading tables:

see following pages



Single-load in 1/2point

| zulässige Belastung in Abhängigkeit von | | | | |
|---|------------|------------|------------------------|------------------|
| allowable load as a function of | | | | |
| | Nrd | Qrd | Interaction at coupler | Deflection L/100 |
| | | | 0,095 | = e [m] |
| L [m] | zul P [kN] | zul P [kN] | zul P [kN] | zul P [kN] |
| 4,00 | 31,67 | 38,12 | 22,09 | 149,63 |
| 5,00 | 25,22 | 37,99 | 18,79 | 95,54 |
| 6,00 | 20,89 | 37,85 | 16,29 | 66,11 |
| 7,00 | 17,78 | 37,72 | 14,34 | 48,33 |
| 8,00 | 15,44 | 37,59 | 12,76 | 36,76 |
| 9,00 | 13,59 | 37,45 | 11,46 | 28,80 |
| 10,00 | 12,11 | 37,32 | 10,37 | 23,07 |
| 11,00 | 10,88 | 37,19 | 9,44 | 18,82 |
| 12,00 | 9,85 | 37,05 | 8,64 | 15,56 |
| 13,00 | 8,96 | 36,92 | 7,93 | 13,00 |
| 14,00 | 8,19 | 36,79 | 7,31 | 10,95 |
| 15,00 | 7,52 | 36,65 | 6,75 | 9,28 |
| 16,00 | 6,92 | 36,52 | 6,25 | 7,89 |
| 17,00 | 6,38 | 36,39 | 5,80 | 6,73 |
| 18,00 | 5,90 | 36,25 | 5,39 | 5,74 |
| 19,00 | 5,46 | 36,12 | 5,01 | 4,89 |
| 20,00 | 5,05 | 35,99 | 4,66 | 4,15 |
| 21,00 | 4,68 | 35,85 | 4,33 | 3,50 |
| 22,00 | 4,34 | 35,72 | 4,03 | 2,92 |
| 23,00 | 4,02 | 35,59 | 3,74 | 2,41 |
| 24,00 | 3,72 | 35,45 | 3,48 | 1,94 |

Note: If the load is applied at the center bottom chord (LC1) it has to be $\leq 5,0$ kN

Single-load in 1/2point

| zulässige Belastung in Abhängigkeit von | | | | |
|---|------------|------------|------------------------|------------------|
| allowable load as a function of | | | | |
| | Nrd | Qrd | Interaction at coupler | Deflection L/200 |
| | | | 0,095 | = e [m] |
| L [m] | zul P [kN] | zul P [kN] | zul P [kN] | zul P [kN] |
| 4,00 | 31,67 | 38,12 | 22,09 | 74,63 |
| 5,00 | 25,22 | 37,99 | 18,79 | 47,54 |
| 6,00 | 20,89 | 37,85 | 16,29 | 32,78 |
| 7,00 | 17,78 | 37,72 | 14,34 | 23,84 |
| 8,00 | 15,44 | 37,59 | 12,76 | 18,01 |
| 9,00 | 13,59 | 37,45 | 11,46 | 13,98 |
| 10,00 | 12,11 | 37,32 | 10,37 | 11,07 |
| 11,00 | 10,88 | 37,19 | 9,44 | 8,90 |
| 12,00 | 9,85 | 37,05 | 8,64 | 7,22 |
| 13,00 | 8,96 | 36,92 | 7,93 | 5,90 |
| 14,00 | 8,19 | 36,79 | 7,31 | 4,83 |
| 15,00 | 7,52 | 36,65 | 6,75 | 3,94 |
| 16,00 | 6,92 | 36,52 | 6,25 | 3,21 |
| 17,00 | 6,38 | 36,39 | 5,80 | 2,58 |
| 18,00 | 5,90 | 36,25 | 5,39 | 2,04 |
| 19,00 | 5,46 | 36,12 | 5,01 | 1,56 |
| 20,00 | 5,05 | 35,99 | 4,66 | 1,15 |
| 21,00 | 4,68 | 35,85 | 4,33 | 0,78 |
| 22,00 | 4,34 | 35,72 | 4,03 | 0,44 |

Note: If the load is applied at the center bottom chord (LC1) it has to be $\leq 5,0$ kN



Single-load in 1/2point

| zulässige Belastung in Abhängigkeit von allowable load as a function of | | | | |
|--|------------|------------|------------------------|------------------|
| | Nrd | Qrd | Interaction at coupler | Deflection L/300 |
| | | | 0,095 | = e [m] |
| L [m] | zul P [kN] | zul P [kN] | zul P [kN] | zul P [kN] |
| 4,00 | 31,67 | 38,12 | 22,09 | 49,63 |
| 5,00 | 25,22 | 37,99 | 18,79 | 31,54 |
| 6,00 | 20,89 | 37,85 | 16,29 | 21,67 |
| 7,00 | 17,78 | 37,72 | 14,34 | 15,68 |
| 8,00 | 15,44 | 37,59 | 12,76 | 11,76 |
| 9,00 | 13,59 | 37,45 | 11,46 | 9,04 |
| 10,00 | 12,11 | 37,32 | 10,37 | 7,07 |
| 11,00 | 10,88 | 37,19 | 9,44 | 5,59 |
| 12,00 | 9,85 | 37,05 | 8,64 | 4,44 |
| 13,00 | 8,96 | 36,92 | 7,93 | 3,53 |
| 14,00 | 8,19 | 36,79 | 7,31 | 2,79 |
| 15,00 | 7,52 | 36,65 | 6,75 | 2,17 |
| 16,00 | 6,92 | 36,52 | 6,25 | 1,64 |
| 17,00 | 6,38 | 36,39 | 5,80 | 1,19 |
| 18,00 | 5,90 | 36,25 | 5,39 | 0,80 |
| 19,00 | 5,46 | 36,12 | 5,01 | 0,46 |
| 20,00 | 5,05 | 35,99 | 4,66 | 0,15 |

Note: If the load is applied at the center bottom chord (LC1) it has to be $\leq 5,0$ kN



5.4 Outer chords + bracing single point load at 1/3-points

System:

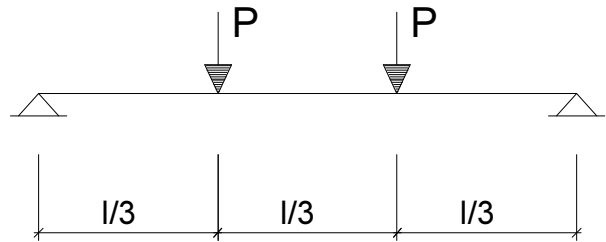

Loading

Psd + gsd

(Net load + selfweight, incl. safety factors)

Normal force in chords:

$$NRd \geq (Psd \cdot L / 3 + gsd \cdot L^2 / 8) / (n \cdot b)$$

$$\Rightarrow Psd \leq [NRd \cdot (n \cdot b) - gsd \cdot L^2 / 8] \cdot 3 / L$$

$$\Rightarrow \text{zul } P = [NRd \cdot (n \cdot b) - gsd \cdot L^2 / 8] \cdot 3 / L / \gamma_F$$

Normal force in bracing:

$$QRd \geq Psd / 2 - gsd \cdot L / 2$$

$$\Rightarrow Psd \leq (QRd + gsd \cdot L / 2)$$

$$\Rightarrow \text{zul } P = (QRd + gsd \cdot L / 2) / \gamma_F$$

Interaction at coupler:

Verification of interaction bending and normal force at coupler by an iterative method.

$$\Rightarrow (Nsd_G / NRd_G)^{1,3} + (Msd_G / MRd_G) < 1,0$$

The coupler is located at $e = 0,095$ m from the coupler

Center chord at bottom:

$$\text{zul } P \leq 5,0 \text{ kN}$$

Limit of deflection:

$$\text{Limit of deflection max. } u = L / f$$

$$\Rightarrow \text{zul } P = [L / f - g \cdot (5/384 \cdot L^4/E/I_{yy})] / (23/684 \cdot L^3/E/I_{yy})$$

3 different limitations are taken into account:

- max. $u = L / 100$
- max. $u = L / 200$
- max. $u = L / 300$

Loading tables:

see following pages



Single-load in 1/3points

| zulässige Belastung in Abhängigkeit von | | | | |
|---|------------|------------|------------------------|------------------|
| allowable load as a function of | | | | |
| | Nrd | Qrd | Interaction at coupler | Deflection L/100 |
| | | | 0,095 | = e [m] |
| L [m] | zul P [kN] | zul P [kN] | zul P [kN] | zul P [kN] |
| 4,00 | 23,75 | 19,06 | 13,58 | 87,83 |
| 5,00 | 18,91 | 18,99 | 11,93 | 56,08 |
| 6,00 | 15,67 | 18,93 | 10,57 | 38,81 |
| 7,00 | 13,34 | 18,86 | 9,45 | 28,37 |
| 8,00 | 11,58 | 18,79 | 8,53 | 21,58 |
| 9,00 | 10,20 | 18,73 | 7,74 | 16,90 |
| 10,00 | 9,08 | 18,66 | 7,07 | 13,54 |
| 11,00 | 8,16 | 18,59 | 6,49 | 11,04 |
| 12,00 | 7,38 | 18,53 | 5,98 | 9,13 |
| 13,00 | 6,72 | 18,46 | 5,52 | 7,63 |
| 14,00 | 6,14 | 18,39 | 5,12 | 6,43 |
| 15,00 | 5,64 | 18,33 | 4,76 | 5,45 |
| 16,00 | 5,19 | 18,26 | 4,43 | 4,63 |
| 17,00 | 4,79 | 18,19 | 4,12 | 3,95 |
| 18,00 | 4,42 | 18,13 | 3,85 | 3,37 |
| 19,00 | 4,09 | 18,06 | 3,59 | 2,87 |
| 20,00 | 3,79 | 17,99 | 3,36 | 2,43 |
| 21,00 | 3,51 | 17,93 | 3,14 | 2,05 |
| 22,00 | 3,26 | 17,86 | 2,93 | 1,71 |
| 23,00 | 3,02 | 17,79 | 2,74 | 1,41 |
| 24,00 | 2,79 | 17,73 | 2,56 | 1,14 |

Note: If the load is applied at the center bottom chord (LC1) it has to be $\leq 5,0$ kN

Single-load in 1/3points

| zulässige Belastung in Abhängigkeit von | | | | |
|---|------------|------------|------------------------|------------------|
| allowable load as a function of | | | | |
| | Nrd | Qrd | Interaction at coupler | Deflection L/200 |
| | | | 0,095 | = e [m] |
| L [m] | zul P [kN] | zul P [kN] | zul P [kN] | zul P [kN] |
| 4,00 | 23,75 | 19,06 | 13,58 | 43,81 |
| 5,00 | 18,91 | 18,99 | 11,93 | 27,90 |
| 6,00 | 15,67 | 18,93 | 10,57 | 19,24 |
| 7,00 | 13,34 | 18,86 | 9,45 | 13,99 |
| 8,00 | 11,58 | 18,79 | 8,53 | 10,57 |
| 9,00 | 10,20 | 18,73 | 7,74 | 8,21 |
| 10,00 | 9,08 | 18,66 | 7,07 | 6,50 |
| 11,00 | 8,16 | 18,59 | 6,49 | 5,22 |
| 12,00 | 7,38 | 18,53 | 5,98 | 4,24 |
| 13,00 | 6,72 | 18,46 | 5,52 | 3,46 |
| 14,00 | 6,14 | 18,39 | 5,12 | 2,83 |
| 15,00 | 5,64 | 18,33 | 4,76 | 2,32 |
| 16,00 | 5,19 | 18,26 | 4,43 | 1,88 |
| 17,00 | 4,79 | 18,19 | 4,12 | 1,51 |
| 18,00 | 4,42 | 18,13 | 3,85 | 1,20 |
| 19,00 | 4,09 | 18,06 | 3,59 | 0,92 |
| 20,00 | 3,79 | 17,99 | 3,36 | 0,67 |
| 21,00 | 3,51 | 17,93 | 3,14 | 0,46 |
| 22,00 | 3,26 | 17,86 | 2,93 | 0,26 |

Note: If the load is applied at the center bottom chord (LC1) it has to be $\leq 5,0$ kN



Single-load in 1/3points

| zulässige Belastung in Abhängigkeit von | | | | |
|---|------------|------------|------------------------|------------------|
| allowable load as a function of | | | | |
| | Nrd | Qrd | Interaction at coupler | Deflection L/300 |
| | | | 0,095 | = e [m] |
| L [m] | zul P [kN] | zul P [kN] | zul P [kN] | zul P [kN] |
| 4,00 | 23,75 | 19,06 | 13,58 | 29,13 |
| 5,00 | 18,91 | 18,99 | 11,93 | 18,51 |
| 6,00 | 15,67 | 18,93 | 10,57 | 12,72 |
| 7,00 | 13,34 | 18,86 | 9,45 | 9,20 |
| 8,00 | 11,58 | 18,79 | 8,53 | 6,90 |
| 9,00 | 10,20 | 18,73 | 7,74 | 5,31 |
| 10,00 | 9,08 | 18,66 | 7,07 | 4,15 |
| 11,00 | 8,16 | 18,59 | 6,49 | 3,28 |
| 12,00 | 7,38 | 18,53 | 5,98 | 2,61 |
| 13,00 | 6,72 | 18,46 | 5,52 | 2,07 |
| 14,00 | 6,14 | 18,39 | 5,12 | 1,63 |
| 15,00 | 5,64 | 18,33 | 4,76 | 1,27 |
| 16,00 | 5,19 | 18,26 | 4,43 | 0,96 |
| 17,00 | 4,79 | 18,19 | 4,12 | 0,70 |
| 18,00 | 4,42 | 18,13 | 3,85 | 0,47 |
| 19,00 | 4,09 | 18,06 | 3,59 | 0,27 |
| 20,00 | 3,79 | 17,99 | 3,36 | 0,09 |

Note: If the load is applied at the center bottom chord (LC1) it has to be $\leq 5,0$ kN



5.5 Outer chords + bracing single point load at 1/4-points

System:

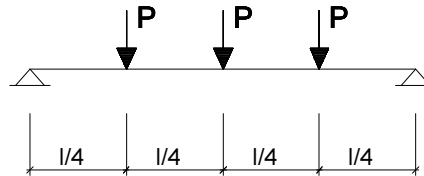

Loading

$P_{sd} + g_{sd}$

(Net load + selfweight, incl. safety factors)

Normal force in chords:

$$N_{Rd} \geq (P_{sd} \cdot L / 4 + g_{sd} \cdot L^2 / 8) / (n \cdot b)$$

$$\Rightarrow P_{sd} \leq [N_{Rd} \cdot (n \cdot b) - g_{sd} \cdot L^2 / 8] \cdot 2 / L$$

$$\Rightarrow \text{zul } P = [N_{Rd} \cdot (n \cdot b) - g_{sd} \cdot L^2 / 8] \cdot 2 / L / \gamma_F$$

Normal force in bracing:

$$Q_{Rd} \geq 3 / 2 \cdot P_{sd} + g_{sd} \cdot L / 2$$

$$\Rightarrow P_{sd} \leq (Q_{Rd} - g_{sd} \cdot L / 2) \cdot 2 / 3$$

$$\Rightarrow \text{zul } P = (Q_{Rd} - g_{sd} \cdot L / 2) \cdot 2 / 3 / \gamma_F$$

Interaction at coupler:

Verification of interaction bending and normal force at coupler by an iterative method.

$$\Rightarrow (N_{sdG} / N_{RdG})^{1,3} + (M_{sdG} / M_{RdG}) < 1,0$$

The coupler is located at $e = 0,095$ m from the coupler

Center chord at bottom:

$$\text{zul } P \leq 5,0 \text{ kN}$$

Limit of deflection:

$$\text{Limit of deflection max. } u = L / f$$

$$\Rightarrow \text{zul } P = [L / f - g \cdot (5/384 \cdot L^4/E/I_{yy})] / (1/20,21 \cdot L^3/E/I_{yy})$$

3 different limitations are taken into account:

$$\text{max. } u = L / 100$$

$$\text{max. } u = L / 200$$

$$\text{max. } u = L / 300$$

Loading tables:

see following pages



Single-load in 1/4points

| zulässige Belastung in Abhängigkeit von | | | | | |
|---|------------|------------|--------------------------|--------------------------|------------------|
| allowable load as a function of | | | | | |
| | Nrd | Qrd | Interaction at coupler 1 | Interaction at coupler 2 | Deflection L/100 |
| | | | 0,095 | 0,095 | = e [m] |
| L [m] | zul P [kN] | zul P [kN] | zul P [kN] | zul P [kN] | zul P [kN] |
| 4,00 | 15,84 | 12,71 | 10,42 | 12,76 | 63,00 |
| 5,00 | 12,61 | 12,66 | 9,31 | 10,56 | 40,23 |
| 6,00 | 10,45 | 12,62 | 8,37 | 8,99 | 27,84 |
| 7,00 | 8,89 | 12,57 | 7,57 | 7,81 | 20,35 |
| 8,00 | 7,72 | 12,53 | 6,90 | 6,89 | 15,48 |
| 9,00 | 6,80 | 12,48 | 6,32 | 6,14 | 12,12 |
| 10,00 | 6,05 | 12,44 | 5,82 | 5,53 | 9,72 |
| 11,00 | 5,44 | 12,40 | 5,38 | 5,01 | 7,92 |
| 12,00 | 4,92 | 12,35 | 4,99 | 4,56 | 6,55 |
| 13,00 | 4,48 | 12,31 | 4,64 | 4,18 | 5,47 |
| 14,00 | 4,10 | 12,26 | 4,33 | 3,84 | 4,61 |
| 15,00 | 3,76 | 12,22 | 4,05 | 3,54 | 3,91 |
| 16,00 | 3,46 | 12,17 | 3,79 | 3,27 | 3,32 |
| 17,00 | 3,19 | 12,13 | 3,55 | 3,02 | 2,83 |
| 18,00 | 2,95 | 12,08 | 3,33 | 2,80 | 2,42 |
| 19,00 | 2,73 | 12,04 | 3,13 | 2,60 | 2,06 |
| 20,00 | 2,53 | 12,00 | 2,94 | 2,41 | 1,75 |
| 21,00 | 2,34 | 11,95 | 2,77 | 2,24 | 1,47 |
| 22,00 | 2,17 | 11,91 | 2,60 | 2,08 | 1,23 |
| 23,00 | 2,01 | 11,86 | 2,44 | 1,93 | 1,01 |
| 24,00 | 1,86 | 11,82 | 2,30 | 1,79 | 0,82 |

Note: If the load is applied at the center bottom chord (LC1) it has to be $\leq 5,0$ kN

Single-load in 1/4points

| zulässige Belastung in Abhängigkeit von | | | | | |
|---|------------|------------|--------------------------|--------------------------|------------------|
| allowable load as a function of | | | | | |
| | Nrd | Qrd | Interaction at coupler 1 | Interaction at coupler 2 | Deflection L/200 |
| | | | 0,095 | 0,095 | = e [m] |
| L [m] | zul P [kN] | zul P [kN] | zul P [kN] | zul P [kN] | zul P [kN] |
| 4,00 | 15,84 | 12,71 | 10,42 | 12,76 | 31,42 |
| 5,00 | 12,61 | 12,66 | 9,31 | 10,56 | 20,02 |
| 6,00 | 10,45 | 12,62 | 8,37 | 8,99 | 13,80 |
| 7,00 | 8,89 | 12,57 | 7,57 | 7,81 | 10,04 |
| 8,00 | 7,72 | 12,53 | 6,90 | 6,89 | 7,58 |
| 9,00 | 6,80 | 12,48 | 6,32 | 6,14 | 5,89 |
| 10,00 | 6,05 | 12,44 | 5,82 | 5,53 | 4,66 |
| 11,00 | 5,44 | 12,40 | 5,38 | 5,01 | 3,75 |
| 12,00 | 4,92 | 12,35 | 4,99 | 4,56 | 3,04 |
| 13,00 | 4,48 | 12,31 | 4,64 | 4,18 | 2,48 |
| 14,00 | 4,10 | 12,26 | 4,33 | 3,84 | 2,03 |
| 15,00 | 3,76 | 12,22 | 4,05 | 3,54 | 1,66 |
| 16,00 | 3,46 | 12,17 | 3,79 | 3,27 | 1,35 |
| 17,00 | 3,19 | 12,13 | 3,55 | 3,02 | 1,09 |
| 18,00 | 2,95 | 12,08 | 3,33 | 2,80 | 0,86 |
| 19,00 | 2,73 | 12,04 | 3,13 | 2,60 | 0,66 |
| 20,00 | 2,53 | 12,00 | 2,94 | 2,41 | 0,48 |
| 21,00 | 2,34 | 11,95 | 2,77 | 2,24 | 0,33 |
| 22,00 | 2,17 | 11,91 | 2,60 | 2,08 | 0,19 |

Note: If the load is applied at the center bottom chord (LC1) it has to be $\leq 5,0$ kN



Single-load in 1/4points

| | zulässige Belastung in Abhängigkeit von | | | | |
|-------|---|------------|--------------------------|--------------------------|------------------|
| | allowable load as a function of | | | | |
| | Nrd | Qrd | Interaction at coupler 1 | Interaction at coupler 2 | Deflection L/300 |
| | | | 0,095 | 0,095 | = e [m] |
| L [m] | zul P [kN] | zul P [kN] | zul P [kN] | zul P [kN] | zul P [kN] |
| 4,00 | 15,84 | 12,71 | 10,42 | 12,76 | 20,90 |
| 5,00 | 12,61 | 12,66 | 9,31 | 10,56 | 13,28 |
| 6,00 | 10,45 | 12,62 | 8,37 | 8,99 | 9,12 |
| 7,00 | 8,89 | 12,57 | 7,57 | 7,81 | 6,60 |
| 8,00 | 7,72 | 12,53 | 6,90 | 6,89 | 4,95 |
| 9,00 | 6,80 | 12,48 | 6,32 | 6,14 | 3,81 |
| 10,00 | 6,05 | 12,44 | 5,82 | 5,53 | 2,98 |
| 11,00 | 5,44 | 12,40 | 5,38 | 5,01 | 2,35 |
| 12,00 | 4,92 | 12,35 | 4,99 | 4,56 | 1,87 |
| 13,00 | 4,48 | 12,31 | 4,64 | 4,18 | 1,49 |
| 14,00 | 4,10 | 12,26 | 4,33 | 3,84 | 1,17 |
| 15,00 | 3,76 | 12,22 | 4,05 | 3,54 | 0,91 |
| 16,00 | 3,46 | 12,17 | 3,79 | 3,27 | 0,69 |
| 17,00 | 3,19 | 12,13 | 3,55 | 3,02 | 0,50 |
| 18,00 | 2,95 | 12,08 | 3,33 | 2,80 | 0,34 |
| 19,00 | 2,73 | 12,04 | 3,13 | 2,60 | 0,19 |
| 20,00 | 2,53 | 12,00 | 2,94 | 2,41 | 0,06 |

Note: If the load is applied at the center bottom chord (LC1) it has to be $\leq 5,0$ kN



5.5 Outer chords + bracing single point load at 1/5-points

System:

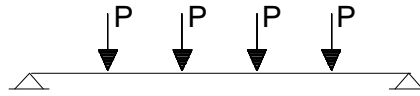

Loading

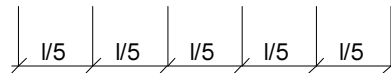

Psd + gsd

(Net load + selfweight, incl. safety factors)

Normal force in chords:

$$\begin{aligned} NR_d &\geq (P_{sd} \cdot 3/5 \cdot L + g_{sd} \cdot L^2/8) / (n \cdot b) \\ \Rightarrow P_{sd} &\leq [NR_d \cdot (n \cdot b) - g_{sd} \cdot L^2/8] \cdot 5/3 \\ \Rightarrow \text{zul } P &= [NR_d \cdot (n \cdot b) - g_{sd} \cdot L^2/8] \cdot 5/3 / L / y_F \end{aligned}$$

Normal force in bracing:

$$\begin{aligned} QR_d &\geq 2 \cdot P_{sd} + g_{sd} \cdot L/2 \\ \Rightarrow P_{sd} &\leq (QR_d - g_{sd} \cdot L/2) / 2 \\ \Rightarrow \text{zul } P &= (QR_d - g_{sd} \cdot L/2) / 2 / y_F \end{aligned}$$

Interaction at coupler:

Verification of interaction bending and normal force at coupler by an iterative method.

$$\Rightarrow (N_{sdG} / NR_{dG})^{1,3} + (M_{sdG} / MR_{dG}) < 1,0$$

The coupler is located at $e = 0,095$ m from the coupler

Center chord at bottom:

$$\text{zul } P \leq 5,0 \text{ kN}$$

Limit of deflection:

$$\begin{aligned} \text{Limit of deflection max. } u &= L / f \\ \Rightarrow \text{zul } P &= [L / f - g \cdot (5/384 \cdot L^4/E/I_{yy})] / (1/15,87 \cdot L^3/E/I_{yy}) \end{aligned}$$

3 different limitations are taken into account:

- max. $u = L / 100$
- max. $u = L / 200$
- max. $u = L / 300$

Loading tables:

see following pages



Single-load in 1/5points

| zulässige Belastung in Abhängigkeit von | | | | | |
|---|------------|------------|--------------------------|--------------------------|------------------|
| allowable load as a function of | | | | | |
| | Nrd | Qrd | Interaction at coupler 1 | Interaction at coupler 2 | Deflection L/100 |
| | | | 0,095 | 0,095 | = e [m] |
| L [m] | zul P [kN] | zul P [kN] | zul P [kN] | zul P [kN] | zul P [kN] |
| 4,00 | 13,20 | 9,53 | 8,59 | 9,35 | 49,47 |
| 5,00 | 10,51 | 9,50 | 7,78 | 7,91 | 31,59 |
| 6,00 | 8,71 | 9,46 | 7,09 | 6,84 | 21,86 |
| 7,00 | 7,41 | 9,43 | 6,48 | 6,01 | 15,98 |
| 8,00 | 6,43 | 9,40 | 5,96 | 5,34 | 12,15 |
| 9,00 | 5,66 | 9,36 | 5,50 | 4,80 | 9,52 |
| 10,00 | 5,05 | 9,33 | 5,10 | 4,34 | 7,63 |
| 11,00 | 4,53 | 9,30 | 4,74 | 3,95 | 6,22 |
| 12,00 | 4,10 | 9,26 | 4,42 | 3,61 | 5,14 |
| 13,00 | 3,73 | 9,23 | 4,13 | 3,32 | 4,30 |
| 14,00 | 3,41 | 9,20 | 3,87 | 3,06 | 3,62 |
| 15,00 | 3,13 | 9,16 | 3,64 | 2,83 | 3,07 |
| 16,00 | 2,88 | 9,13 | 3,42 | 2,62 | 2,61 |
| 17,00 | 2,66 | 9,10 | 3,22 | 2,43 | 2,23 |
| 18,00 | 2,46 | 9,06 | 3,04 | 2,26 | 1,90 |
| 19,00 | 2,27 | 9,03 | 2,87 | 2,10 | 1,62 |
| 20,00 | 2,11 | 9,00 | 2,71 | 1,95 | 1,37 |
| 21,00 | 1,95 | 8,96 | 2,56 | 1,82 | 1,16 |
| 22,00 | 1,81 | 8,93 | 2,42 | 1,69 | 0,97 |
| 23,00 | 1,68 | 8,90 | 2,28 | 1,57 | 0,80 |
| 24,00 | 1,55 | 8,86 | 2,16 | 1,46 | 0,64 |

Note: If the load is applied at the center bottom chord (LC1) it has to be $\leq 5,0$ kN

Single-load in 1/5points

| zulässige Belastung in Abhängigkeit von | | | | | |
|---|------------|------------|--------------------------|--------------------------|------------------|
| allowable load as a function of | | | | | |
| | Nrd | Qrd | Interaction at coupler 1 | Interaction at coupler 2 | Deflection L/200 |
| | | | 0,095 | 0,095 | = e [m] |
| L [m] | zul P [kN] | zul P [kN] | zul P [kN] | zul P [kN] | zul P [kN] |
| 4,00 | 13,20 | 9,53 | 8,59 | 9,35 | 24,67 |
| 5,00 | 10,51 | 9,50 | 7,78 | 7,91 | 15,72 |
| 6,00 | 8,71 | 9,46 | 7,09 | 6,84 | 10,84 |
| 7,00 | 7,41 | 9,43 | 6,48 | 6,01 | 7,88 |
| 8,00 | 6,43 | 9,40 | 5,96 | 5,34 | 5,95 |
| 9,00 | 5,66 | 9,36 | 5,50 | 4,80 | 4,62 |
| 10,00 | 5,05 | 9,33 | 5,10 | 4,34 | 3,66 |
| 11,00 | 4,53 | 9,30 | 4,74 | 3,95 | 2,94 |
| 12,00 | 4,10 | 9,26 | 4,42 | 3,61 | 2,39 |
| 13,00 | 3,73 | 9,23 | 4,13 | 3,32 | 1,95 |
| 14,00 | 3,41 | 9,20 | 3,87 | 3,06 | 1,60 |
| 15,00 | 3,13 | 9,16 | 3,64 | 2,83 | 1,30 |
| 16,00 | 2,88 | 9,13 | 3,42 | 2,62 | 1,06 |
| 17,00 | 2,66 | 9,10 | 3,22 | 2,43 | 0,85 |
| 18,00 | 2,46 | 9,06 | 3,04 | 2,26 | 0,67 |
| 19,00 | 2,27 | 9,03 | 2,87 | 2,10 | 0,52 |
| 20,00 | 2,11 | 9,00 | 2,71 | 1,95 | 0,38 |
| 21,00 | 1,95 | 8,96 | 2,56 | 1,82 | 0,26 |
| 22,00 | 1,81 | 8,93 | 2,42 | 1,69 | 0,15 |

Note: If the load is applied at the center bottom chord (LC1) it has to be $\leq 5,0$ kN



Single-load in 1/5points

| | zulässige Belastung in Abhängigkeit von | | | | |
|-------|---|------------|--------------------------|--------------------------|------------------|
| | allowable load as a function of | | | | |
| | Nrd | Qrd | Interaction at coupler 1 | Interaction at coupler 2 | Deflection L/300 |
| | | | 0,095 | 0,095 | = e [m] |
| L [m] | zul P [kN] | zul P [kN] | zul P [kN] | zul P [kN] | zul P [kN] |
| 4,00 | 13,20 | 9,53 | 8,59 | 9,35 | 16,41 |
| 5,00 | 10,51 | 9,50 | 7,78 | 7,91 | 10,43 |
| 6,00 | 8,71 | 9,46 | 7,09 | 6,84 | 7,16 |
| 7,00 | 7,41 | 9,43 | 6,48 | 6,01 | 5,18 |
| 8,00 | 6,43 | 9,40 | 5,96 | 5,34 | 3,89 |
| 9,00 | 5,66 | 9,36 | 5,50 | 4,80 | 2,99 |
| 10,00 | 5,05 | 9,33 | 5,10 | 4,34 | 2,34 |
| 11,00 | 4,53 | 9,30 | 4,74 | 3,95 | 1,85 |
| 12,00 | 4,10 | 9,26 | 4,42 | 3,61 | 1,47 |
| 13,00 | 3,73 | 9,23 | 4,13 | 3,32 | 1,17 |
| 14,00 | 3,41 | 9,20 | 3,87 | 3,06 | 0,92 |
| 15,00 | 3,13 | 9,16 | 3,64 | 2,83 | 0,72 |
| 16,00 | 2,88 | 9,13 | 3,42 | 2,62 | 0,54 |
| 17,00 | 2,66 | 9,10 | 3,22 | 2,43 | 0,39 |
| 18,00 | 2,46 | 9,06 | 3,04 | 2,26 | 0,27 |
| 19,00 | 2,27 | 9,03 | 2,87 | 2,10 | 0,15 |
| 20,00 | 2,11 | 9,00 | 2,71 | 1,95 | 0,05 |

Note: If the load is applied at the center bottom chord (LC1) it has to be $\leq 5,0$ kN



6 SUMMARY OF RESULTS

6.1 Allowable loadings at center bottom chord (LC1):

The values of the following tables are only valid for single-span girder.

The truss-elements have to be braced with diagonals.

Loads have to be applied acc. chapter 1.4.

Loads at the middle of the couplers are not allowed.

The specified values include partial safety coefficients on the loadings side acc. EN 1990 of $\gamma_F = 1.50$ for payloads and $\gamma_G = 1.35$ for selfweight of the truss.

For applications which can be calculated on the basis of other codes, the partial safety factors can be adjusted (for example temporary structures acc. EN 13814, $\gamma_F = 1.35$ for payloads).

To use the resulting allowable loads with British Standard (BS) and ANSI, allowable loads listed in tables have to be multiplied by 0.85.

6.1.1 Limitation of deflection = L/100

Allowable load F45 Loading applied on the central bottom chord

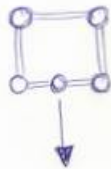

| Span | | UDL on cBC | | Einzellasten / Single point loads | | | | | | | |
|------------|------|------------|----------|-----------------------------------|-------|---------------|-------|---------------|-------|---------------|-------|
| Spannweite | | UDL on cBC | | in 1/2 Point | | in 1/3 Points | | in 1/4 Points | | in 1/5 Points | |
| [m] | [ft] | [kg/m] | [lbs/ft] | [kg] | [lbs] | [kg] | [lbs] | [kg] | [lbs] | [kg] | [lbs] |
| 4 | 13,1 | 600 | 403 | 500 | 1103 | 500 | 1103 | 500 | 1103 | 500 | 1103 |
| 5 | 16,4 | 600 | 403 | 500 | 1103 | 500 | 1103 | 500 | 1103 | 500 | 1103 |
| 6 | 19,7 | 600 | 403 | 500 | 1103 | 500 | 1103 | 500 | 1103 | 500 | 1103 |
| 7 | 23,0 | 473 | 318 | 500 | 1103 | 500 | 1103 | 500 | 1103 | 500 | 1103 |
| 8 | 26,2 | 365 | 245 | 500 | 1103 | 500 | 1103 | 500 | 1103 | 500 | 1103 |
| 9 | 29,5 | 289 | 194 | 500 | 1103 | 500 | 1103 | 500 | 1103 | 480 | 1057 |
| 10 | 32,8 | 234 | 157 | 500 | 1103 | 500 | 1103 | 500 | 1103 | 434 | 957 |
| 11 | 36,1 | 192 | 129 | 500 | 1103 | 500 | 1103 | 500 | 1103 | 395 | 871 |
| 12 | 39,4 | 160 | 108 | 500 | 1103 | 500 | 1103 | 456 | 1006 | 361 | 797 |
| 13 | 42,7 | 135 | 91 | 500 | 1103 | 500 | 1103 | 418 | 921 | 332 | 732 |
| 14 | 45,9 | 115 | 77 | 500 | 1103 | 500 | 1103 | 384 | 846 | 306 | 675 |
| 15 | 49,2 | 99 | 66 | 500 | 1103 | 476 | 1049 | 354 | 780 | 283 | 624 |
| 16 | 52,5 | 79 | 53 | 500 | 1103 | 443 | 976 | 327 | 720 | 261 | 575 |
| 17 | 55,8 | 63 | 43 | 500 | 1103 | 395 | 871 | 283 | 625 | 223 | 491 |
| 18 | 59,1 | 51 | 34 | 500 | 1103 | 337 | 743 | 242 | 533 | 190 | 419 |
| 19 | 62,3 | 41 | 28 | 489 | 1078 | 287 | 633 | 206 | 454 | 162 | 356 |
| 20 | 65,6 | 33 | 22 | 415 | 915 | 243 | 537 | 175 | 385 | 137 | 302 |
| 21 | 68,9 | 27 | 18 | 350 | 771 | 205 | 453 | 147 | 325 | 116 | 255 |
| 22 | 72,2 | 21 | 14 | 292 | 644 | 171 | 378 | 123 | 271 | 97 | 213 |
| 23 | 75,5 | 17 | 11 | 241 | 531 | 141 | 312 | 101 | 223 | 80 | 176 |
| 24 | 78,7 | 13 | 9 | 194 | 429 | 114 | 252 | 82 | 181 | 64 | 142 |



Load limited by allowable local loading on the Bottom chord



Load limited by allowable deflection of L/100



6.1.2 Limitation of deflection = L/200

Allowable load F45 Loading applied on the central bottom chord

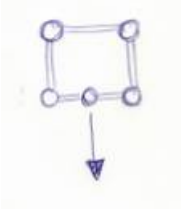

| Span | | Einzellasten / Single point loads | | | | | | | | | |
|------------|------|-----------------------------------|----------|--------------|-------|---------------|-------|---------------|-------|---------------|-------|
| Spannweite | | UDL on cBC | | in 1/2 Point | | in 1/3 Points | | in 1/4 Points | | in 1/5 Points | |
| [m] | [ft] | [kg/m] | [lbs/ft] | [kg] | [lbs] | [kg] | [lbs] | [kg] | [lbs] | [kg] | [lbs] |
| 4 | 13,1 | 600 | 403 | 500 | 1103 | 500 | 1103 | 500 | 1103 | 500 | 1103 |
| 5 | 16,4 | 600 | 403 | 500 | 1103 | 500 | 1103 | 500 | 1103 | 500 | 1103 |
| 6 | 19,7 | 600 | 403 | 500 | 1103 | 500 | 1103 | 500 | 1103 | 500 | 1103 |
| 7 | 23,0 | 473 | 318 | 500 | 1103 | 500 | 1103 | 500 | 1103 | 500 | 1103 |
| 8 | 26,2 | 360 | 242 | 500 | 1103 | 500 | 1103 | 500 | 1103 | 500 | 1103 |
| 9 | 29,5 | 249 | 167 | 500 | 1103 | 500 | 1103 | 500 | 1103 | 462 | 1019 |
| 10 | 32,8 | 177 | 119 | 500 | 1103 | 500 | 1103 | 466 | 1028 | 366 | 807 |
| 11 | 36,1 | 129 | 87 | 500 | 1103 | 500 | 1103 | 375 | 826 | 294 | 649 |
| 12 | 39,4 | 96 | 65 | 500 | 1103 | 424 | 935 | 304 | 671 | 239 | 527 |
| 13 | 42,7 | 73 | 49 | 500 | 1103 | 346 | 763 | 248 | 547 | 195 | 430 |
| 14 | 45,9 | 55 | 37 | 483 | 1064 | 283 | 625 | 203 | 448 | 160 | 352 |
| 15 | 49,2 | 42 | 28 | 394 | 870 | 232 | 511 | 166 | 366 | 130 | 288 |
| 16 | 52,5 | 32 | 22 | 321 | 707 | 188 | 415 | 135 | 298 | 106 | 234 |
| 17 | 55,8 | 24 | 16 | 258 | 569 | 151 | 334 | 109 | 239 | 85 | 188 |
| 18 | 59,1 | 18 | 12 | 204 | 449 | 120 | 264 | 86 | 189 | 67 | 149 |
| 19 | 62,3 | 13 | 9 | 156 | 345 | 92 | 203 | 66 | 145 | 52 | 114 |
| 20 | 65,6 | 9 | 6 | 115 | 253 | 67 | 149 | 48 | 107 | 38 | 84 |
| 21 | 68,9 | 6 | 4 | 78 | 171 | 46 | 101 | 33 | 72 | 26 | 57 |
| 22 | 72,2 | 3 | 2 | 44 | 98 | 26 | 57 | 19 | 41 | 15 | 32 |



Load limited by allowable local loading on the Bottom chord



Load limited by allowable deflection of L/200



6.1.3 Limitation of deflection = L/300

Allowable load F45 Loading applied on the central bottom chord



| Span | | Einzellasten / Single point loads | | | | | | | | | |
|------------|------|-----------------------------------|----------|--------------|-------|---------------|-------|---------------|-------|---------------|-------|
| Spannweite | | UDL on cBC | | in 1/2 Point | | in 1/3 Points | | in 1/4 Points | | in 1/5 Points | |
| [m] | [ft] | [kg/m] | [lbs/ft] | [kg] | [lbs] | [kg] | [lbs] | [kg] | [lbs] | [kg] | [lbs] |
| 4 | 13,1 | 600 | 403 | 500 | 1103 | 500 | 1103 | 500 | 1103 | 500 | 1103 |
| 5 | 16,4 | 600 | 403 | 500 | 1103 | 500 | 1103 | 500 | 1103 | 500 | 1103 |
| 6 | 19,7 | 578 | 388 | 500 | 1103 | 500 | 1103 | 500 | 1103 | 500 | 1103 |
| 7 | 23,0 | 358 | 241 | 500 | 1103 | 500 | 1103 | 500 | 1103 | 500 | 1103 |
| 8 | 26,2 | 235 | 158 | 500 | 1103 | 500 | 1103 | 495 | 1092 | 389 | 857 |
| 9 | 29,5 | 161 | 108 | 500 | 1103 | 500 | 1103 | 381 | 840 | 299 | 659 |
| 10 | 32,8 | 113 | 76 | 500 | 1103 | 415 | 916 | 298 | 657 | 234 | 516 |
| 11 | 36,1 | 81 | 55 | 500 | 1103 | 328 | 724 | 235 | 519 | 185 | 408 |
| 12 | 39,4 | 59 | 40 | 444 | 980 | 261 | 575 | 187 | 413 | 147 | 324 |
| 13 | 42,7 | 43 | 29 | 353 | 778 | 207 | 457 | 149 | 328 | 117 | 257 |
| 14 | 45,9 | 32 | 21 | 279 | 614 | 163 | 360 | 117 | 259 | 92 | 203 |
| 15 | 49,2 | 23 | 16 | 217 | 478 | 127 | 280 | 91 | 201 | 72 | 158 |
| 16 | 52,5 | 16 | 11 | 164 | 362 | 96 | 213 | 69 | 153 | 54 | 120 |
| 17 | 55,8 | 11 | 8 | 119 | 263 | 70 | 155 | 50 | 111 | 39 | 87 |
| 18 | 59,1 | 7 | 5 | 80 | 177 | 47 | 104 | 34 | 75 | 27 | 59 |
| 19 | 62,3 | 4 | 3 | 46 | 101 | 27 | 59 | 19 | 42 | 15 | 33 |
| 20 | 65,6 | 1 | 1 | 15 | 33 | 9 | 19 | 6 | 14 | 5 | 11 |



Load limited by allowable local loading on the Bottom chord



Load limited by allowable deflection of L/300



6.2 Allowable loadings at side chord (LC2):

The values of the following tables are only valid for single-span girder.

The truss-elements have to be braced with diagonals.

Loads have to be applied acc. chapter 1.4.

Loads at the middle of the couplers are not allowed.

The specified values include partial safety coefficients on the loadings side acc. EN 1990 of $\gamma_F = 1.50$ for payloads and $\gamma_G = 1.35$ for selfweight of the truss.

For applications which can be calculated on the basis of other codes, the partial safety factors can be adjusted (for example temporary structures acc. EN 13814, $\gamma_F = 1.35$ for payloads).

To use the resulting allowable loads with British Standard (BS) and ANSI, allowable loads listed in tables have to be multiplied by 0.85.

6.2.1 Limitation of deflection = L/100

Allowable load F45 Loading applied on the side chords



Einzellasten / Single point loads

| Span | | UDL on cBC | | in 1/2 Point | | in 1/3 Points | | in 1/4 Points | | in 1/5 Points | |
|------------|------|------------|----------|--------------|-------|----------------|-------|----------------|-------|----------------|-------|
| Spannweite | | UDL on cBC | | in 1/2 Punkt | | in 1/3 Punkten | | in 1/4 Punkten | | in 1/5 Punkten | |
| [m] | [ft] | [kg/m] | [lbs/ft] | [kg] | [lbs] | [kg] | [lbs] | [kg] | [lbs] | [kg] | [lbs] |
| 4 | 13,1 | 953 | 640 | 2209 | 4870 | 1358 | 2994 | 1042 | 2298 | 859 | 1895 |
| 5 | 16,4 | 760 | 511 | 1879 | 4143 | 1193 | 2631 | 931 | 2053 | 778 | 1716 |
| 6 | 19,7 | 631 | 424 | 1629 | 3593 | 1057 | 2330 | 837 | 1845 | 684 | 1507 |
| 7 | 23,0 | 473 | 318 | 1434 | 3161 | 945 | 2084 | 757 | 1670 | 601 | 1324 |
| 8 | 26,2 | 365 | 245 | 1276 | 2814 | 853 | 1880 | 689 | 1519 | 534 | 1178 |
| 9 | 29,5 | 289 | 194 | 1146 | 2527 | 774 | 1707 | 614 | 1354 | 480 | 1057 |
| 10 | 32,8 | 234 | 157 | 1037 | 2287 | 707 | 1559 | 553 | 1218 | 434 | 957 |
| 11 | 36,1 | 192 | 129 | 944 | 2082 | 649 | 1431 | 501 | 1104 | 395 | 871 |
| 12 | 39,4 | 160 | 108 | 864 | 1904 | 598 | 1318 | 456 | 1006 | 361 | 797 |
| 13 | 42,7 | 135 | 91 | 793 | 1749 | 552 | 1218 | 418 | 921 | 332 | 732 |
| 14 | 45,9 | 115 | 77 | 731 | 1612 | 512 | 1129 | 384 | 846 | 306 | 675 |
| 15 | 49,2 | 99 | 66 | 675 | 1489 | 476 | 1049 | 354 | 780 | 283 | 624 |
| 16 | 52,5 | 79 | 53 | 625 | 1379 | 443 | 976 | 327 | 720 | 261 | 575 |
| 17 | 55,8 | 63 | 43 | 580 | 1279 | 395 | 871 | 283 | 625 | 223 | 491 |
| 18 | 59,1 | 51 | 34 | 539 | 1188 | 337 | 743 | 242 | 533 | 190 | 419 |
| 19 | 62,3 | 41 | 28 | 489 | 1078 | 287 | 633 | 206 | 454 | 162 | 356 |
| 20 | 65,6 | 33 | 22 | 415 | 915 | 243 | 537 | 175 | 385 | 137 | 302 |
| 21 | 68,9 | 27 | 18 | 350 | 771 | 205 | 453 | 147 | 325 | 116 | 255 |
| 22 | 72,2 | 21 | 14 | 292 | 644 | 171 | 378 | 123 | 271 | 97 | 213 |
| 23 | 75,5 | 17 | 11 | 241 | 531 | 141 | 312 | 101 | 223 | 80 | 176 |
| 24 | 78,7 | 13 | 9 | 194 | 429 | 114 | 252 | 82 | 181 | 64 | 142 |

Load limited by allowable deflection of L/100



6.2.2 Limitation of deflection = L/200

Allowable load F45 Loading applied on the side chords



| Span | | Einzellasten / Single point loads | | | | | | | | | |
|------------|------|-----------------------------------|----------|--------------|-------|---------------|-------|---------------|-------|---------------|-------|
| Spannweite | | UDL on cBC | | in 1/2 Point | | in 1/3 Points | | in 1/4 Points | | in 1/5 Points | |
| [m] | [ft] | [kg/m] | [lbs/ft] | [kg] | [lbs] | [kg] | [lbs] | [kg] | [lbs] | [kg] | [lbs] |
| 4 | 13,1 | 953 | 640 | 2209 | 4870 | 1358 | 2994 | 1042 | 2298 | 859 | 1895 |
| 5 | 16,4 | 760 | 511 | 1879 | 4143 | 1193 | 2631 | 931 | 2053 | 778 | 1716 |
| 6 | 19,7 | 631 | 424 | 1629 | 3593 | 1057 | 2330 | 837 | 1845 | 684 | 1507 |
| 7 | 23,0 | 473 | 318 | 1434 | 3161 | 945 | 2084 | 757 | 1670 | 601 | 1324 |
| 8 | 26,2 | 360 | 242 | 1276 | 2814 | 853 | 1880 | 689 | 1519 | 534 | 1178 |
| 9 | 29,5 | 249 | 167 | 1146 | 2527 | 774 | 1707 | 589 | 1298 | 462 | 1019 |
| 10 | 32,8 | 177 | 119 | 1037 | 2287 | 650 | 1433 | 466 | 1028 | 366 | 807 |
| 11 | 36,1 | 129 | 87 | 890 | 1962 | 522 | 1152 | 375 | 826 | 294 | 649 |
| 12 | 39,4 | 96 | 65 | 722 | 1593 | 424 | 935 | 304 | 671 | 239 | 527 |
| 13 | 42,7 | 73 | 49 | 590 | 1300 | 346 | 763 | 248 | 547 | 195 | 430 |
| 14 | 45,9 | 55 | 37 | 483 | 1064 | 283 | 625 | 203 | 448 | 160 | 352 |
| 15 | 49,2 | 42 | 28 | 394 | 870 | 232 | 511 | 166 | 366 | 130 | 288 |
| 16 | 52,5 | 32 | 22 | 321 | 707 | 188 | 415 | 135 | 298 | 106 | 234 |
| 17 | 55,8 | 24 | 16 | 258 | 569 | 151 | 334 | 109 | 239 | 85 | 188 |
| 18 | 59,1 | 18 | 12 | 204 | 449 | 120 | 264 | 86 | 189 | 67 | 149 |
| 19 | 62,3 | 13 | 9 | 156 | 345 | 92 | 203 | 66 | 145 | 52 | 114 |
| 20 | 65,6 | 9 | 6 | 115 | 253 | 67 | 149 | 48 | 107 | 38 | 84 |
| 21 | 68,9 | 6 | 4 | 78 | 171 | 46 | 101 | 33 | 72 | 26 | 57 |
| 22 | 72,2 | 3 | 2 | 44 | 98 | 26 | 57 | 19 | 41 | 15 | 32 |



6.2.3 Limitation of deflection = L/300

Allowable load F45 Loading applied on the side chords



| Span | | Einzellasten / Single point loads | | | | | | | | | |
|------------|------|-----------------------------------|----------|----------------|-------|----------------|-------|----------------|-------|------|-------|
| UDL on cBC | | in 1/2 Point | | in 1/3 Points | | in 1/4 Points | | in 1/5 Points | | | |
| UDL on cBC | | in 1/2 Punkt | | in 1/3 Punkten | | in 1/4 Punkten | | in 1/5 Punkten | | | |
| [m] | [ft] | [kg/m] | [lbs/ft] | [kg] | [lbs] | [kg] | [lbs] | [kg] | [lbs] | [kg] | [lbs] |
| 4 | 13,1 | 953 | 640 | 2209 | 4870 | 1358 | 2994 | 1042 | 2298 | 859 | 1895 |
| 5 | 16,4 | 760 | 511 | 1879 | 4143 | 1193 | 2631 | 931 | 2053 | 778 | 1716 |
| 6 | 19,7 | 578 | 388 | 1629 | 3593 | 1057 | 2330 | 837 | 1845 | 684 | 1507 |
| 7 | 23,0 | 358 | 241 | 1434 | 3161 | 920 | 2029 | 660 | 1456 | 518 | 1143 |
| 8 | 26,2 | 235 | 158 | 1176 | 2593 | 690 | 1522 | 495 | 1092 | 389 | 857 |
| 9 | 29,5 | 161 | 108 | 904 | 1994 | 531 | 1170 | 381 | 840 | 299 | 659 |
| 10 | 32,8 | 113 | 76 | 707 | 1560 | 415 | 916 | 298 | 657 | 234 | 516 |
| 11 | 36,1 | 81 | 55 | 559 | 1233 | 328 | 724 | 235 | 519 | 185 | 408 |
| 12 | 39,4 | 59 | 40 | 444 | 980 | 261 | 575 | 187 | 413 | 147 | 324 |
| 13 | 42,7 | 43 | 29 | 353 | 778 | 207 | 457 | 149 | 328 | 117 | 257 |
| 14 | 45,9 | 32 | 21 | 279 | 614 | 163 | 360 | 117 | 259 | 92 | 203 |
| 15 | 49,2 | 23 | 16 | 217 | 478 | 127 | 280 | 91 | 201 | 72 | 158 |
| 16 | 52,5 | 16 | 11 | 164 | 362 | 96 | 213 | 69 | 153 | 54 | 120 |
| 17 | 55,8 | 11 | 8 | 119 | 263 | 70 | 155 | 50 | 111 | 39 | 87 |
| 18 | 59,1 | 7 | 5 | 80 | 177 | 47 | 104 | 34 | 75 | 27 | 59 |
| 19 | 62,3 | 4 | 3 | 46 | 101 | 27 | 59 | 19 | 42 | 15 | 33 |
| 20 | 65,6 | 1 | 1 | 15 | 33 | 9 | 19 | 6 | 14 | 5 | 11 |

Load limited by allowable deflection of L/300



6.3 Deflections at max. allowable loadings on center bottom chords (LC1):

6.3.1 Limitation of deflection = L/100

Deflections [cm] for F45 at max. allowable loading on central Bottom chord

Vorhandene Durchbiegung [cm] F45 unter max. zul. Lasten

| Span | | UDL | | Einzellasten/ Single point loads | | | | | | | |
|------|------|-------|--------|----------------------------------|--------|---------------|--------|---------------|--------|---------------|--------|
| | | | | in 1/2 Point | | in 1/3 Points | | in 1/4 Points | | in 1/5 Points | |
| [m] | [ft] | [cm] | [inch] | [cm] | [inch] | [cm] | [inch] | [cm] | [inch] | [cm] | [inch] |
| 4 | 13,1 | 0,41 | 0,16 | 0,14 | 0,06 | 0,24 | 0,09 | 0,33 | 0,13 | 0,41 | 0,16 |
| 5 | 16,4 | 1,00 | 0,39 | 0,28 | 0,11 | 0,47 | 0,18 | 0,64 | 0,25 | 0,81 | 0,32 |
| 6 | 19,7 | 2,07 | 0,82 | 0,50 | 0,20 | 0,82 | 0,32 | 1,12 | 0,44 | 1,41 | 0,56 |
| 7 | 23,0 | 3,05 | 1,20 | 0,81 | 0,32 | 1,31 | 0,52 | 1,79 | 0,70 | 2,25 | 0,89 |
| 8 | 26,2 | 4,05 | 1,60 | 1,22 | 0,48 | 1,98 | 0,78 | 2,69 | 1,06 | 3,38 | 1,33 |
| 9 | 29,5 | 5,19 | 2,05 | 1,77 | 0,70 | 2,84 | 1,12 | 3,86 | 1,52 | 4,66 | 1,83 |
| 10 | 32,8 | 6,47 | 2,55 | 2,47 | 0,97 | 3,94 | 1,55 | 5,33 | 2,10 | 5,85 | 2,30 |
| 11 | 36,1 | 7,89 | 3,11 | 3,34 | 1,31 | 5,29 | 2,08 | 7,15 | 2,82 | 7,19 | 2,83 |
| 12 | 39,4 | 9,44 | 3,72 | 4,40 | 1,73 | 6,93 | 2,73 | 8,60 | 3,39 | 8,67 | 3,41 |
| 13 | 42,7 | 11,14 | 4,38 | 5,68 | 2,24 | 8,90 | 3,50 | 10,18 | 4,01 | 10,29 | 4,05 |
| 14 | 45,9 | 12,97 | 5,11 | 7,20 | 2,83 | 11,22 | 4,42 | 11,90 | 4,68 | 12,07 | 4,75 |
| 15 | 49,2 | 14,95 | 5,89 | 8,98 | 3,54 | 13,35 | 5,25 | 13,76 | 5,42 | 13,98 | 5,51 |
| 16 | 52,5 | 16,00 | 6,30 | 11,06 | 4,35 | 15,40 | 6,06 | 15,77 | 6,21 | 16,00 | 6,30 |
| 17 | 55,8 | 17,00 | 6,69 | 13,46 | 5,30 | 17,00 | 6,69 | 17,00 | 6,69 | 17,00 | 6,69 |
| 18 | 59,1 | 18,00 | 7,09 | 16,20 | 6,38 | 18,00 | 7,09 | 18,00 | 7,09 | 18,00 | 7,09 |
| 19 | 62,3 | 19,00 | 7,48 | 19,00 | 6,38 | 19,00 | 7,48 | 19,00 | 7,48 | 19,00 | 7,48 |
| 20 | 65,6 | 20,00 | 7,87 | 20,00 | 6,38 | 20,00 | 7,87 | 20,00 | 7,87 | 20,00 | 7,87 |
| 21 | 68,9 | 21,00 | 8,27 | 21,00 | 6,38 | 21,00 | 8,27 | 21,00 | 8,27 | 21,00 | 8,27 |
| 22 | 72,2 | 22,00 | 8,66 | 22,00 | 6,38 | 22,00 | 8,66 | 22,00 | 8,66 | 22,00 | 8,66 |
| 23 | 75,5 | 23,00 | 9,06 | 23,00 | 6,38 | 23,00 | 9,06 | 23,00 | 9,06 | 23,00 | 9,06 |
| 24 | 78,7 | 24,00 | 9,45 | 24,00 | 6,38 | 24,00 | 9,45 | 24,00 | 9,45 | 24,00 | 9,45 |

6.3.2 Limitation of deflection = L/200

Deflections [cm] for F45 at max. allowable loading on central Bottom chord

Vorhandene Durchbiegung [cm] F45 unter max. zul. Lasten

| Span | | UDL | | Einzellasten/ Single point loads | | | | | | | |
|------|------|-------|--------|----------------------------------|--------|---------------|--------|---------------|--------|---------------|--------|
| | | | | in 1/2 Point | | in 1/3 Points | | in 1/4 Points | | in 1/5 Points | |
| [m] | [ft] | [cm] | [inch] | [cm] | [inch] | [cm] | [inch] | [cm] | [inch] | [cm] | [inch] |
| 4 | 13,1 | 0,41 | 0,16 | 0,14 | 0,06 | 0,24 | 0,09 | 0,33 | 0,13 | 0,41 | 0,16 |
| 5 | 16,4 | 1,00 | 0,39 | 0,28 | 0,11 | 0,47 | 0,18 | 0,64 | 0,25 | 0,81 | 0,32 |
| 6 | 19,7 | 2,07 | 0,82 | 0,50 | 0,20 | 0,82 | 0,32 | 1,12 | 0,44 | 1,41 | 0,56 |
| 7 | 23,0 | 3,05 | 1,20 | 0,81 | 0,32 | 1,31 | 0,52 | 1,79 | 0,70 | 2,25 | 0,89 |
| 8 | 26,2 | 4,00 | 1,57 | 1,22 | 0,48 | 1,98 | 0,78 | 2,69 | 1,06 | 3,38 | 1,33 |
| 9 | 29,5 | 4,50 | 1,77 | 1,77 | 0,70 | 2,84 | 1,12 | 3,86 | 1,52 | 4,50 | 1,77 |
| 10 | 32,8 | 5,00 | 1,97 | 2,47 | 0,97 | 3,94 | 1,55 | 5,00 | 1,97 | 5,00 | 1,97 |
| 11 | 36,1 | 5,50 | 2,17 | 3,34 | 1,31 | 5,29 | 2,08 | 5,50 | 2,17 | 5,50 | 2,17 |
| 12 | 39,4 | 6,00 | 2,36 | 4,40 | 1,73 | 6,00 | 2,36 | 6,00 | 2,36 | 6,00 | 2,36 |
| 13 | 42,7 | 6,50 | 2,56 | 5,68 | 2,24 | 6,50 | 2,56 | 6,50 | 2,56 | 6,50 | 2,56 |
| 14 | 45,9 | 7,00 | 2,76 | 7,00 | 2,76 | 7,00 | 2,76 | 7,00 | 2,76 | 7,00 | 2,76 |
| 15 | 49,2 | 7,50 | 2,95 | 7,50 | 2,95 | 7,50 | 2,95 | 7,50 | 2,95 | 7,50 | 2,95 |
| 16 | 52,5 | 8,00 | 3,15 | 8,00 | 3,15 | 8,00 | 3,15 | 8,00 | 3,15 | 8,00 | 3,15 |
| 17 | 55,8 | 8,50 | 3,35 | 8,50 | 3,35 | 8,50 | 3,35 | 8,50 | 3,35 | 8,50 | 3,35 |
| 18 | 59,1 | 9,00 | 3,54 | 9,00 | 3,54 | 9,00 | 3,54 | 9,00 | 3,54 | 9,00 | 3,54 |
| 19 | 62,3 | 9,50 | 3,74 | 9,50 | 3,74 | 9,50 | 3,74 | 9,50 | 3,74 | 9,50 | 3,74 |
| 20 | 65,6 | 10,00 | 3,94 | 10,00 | 3,94 | 10,00 | 3,94 | 10,00 | 3,94 | 10,00 | 3,94 |
| 21 | 68,9 | 10,50 | 4,13 | 10,50 | 4,13 | 10,50 | 4,13 | 10,50 | 4,13 | 10,50 | 4,13 |
| 22 | 72,2 | 11,00 | 4,33 | 11,00 | 4,33 | 11,00 | 4,33 | 11,00 | 4,33 | 11,00 | 4,33 |



6.3.3 Limitation of deflection = L/300

Deflections [cm] for F45 at max. allowable loading on central Bottom chord

Vorhandene Durchbiegung [cm] F45 unter max. zul. Lasten

| Span | | UDL | | Einzellasten/ Single point loads | | | | | | | |
|------|------|------|--------|----------------------------------|--------|---------------|--------|---------------|--------|---------------|--------|
| | | | | in 1/2 Point | | in 1/3 Points | | in 1/4 Points | | in 1/5 Points | |
| [m] | [ft] | [cm] | [inch] | [cm] | [inch] | [cm] | [inch] | [cm] | [inch] | [cm] | [inch] |
| 4 | 13,1 | 0,41 | 0,16 | 0,14 | 0,06 | 0,24 | 0,09 | 0,33 | 0,13 | 0,41 | 0,16 |
| 5 | 16,4 | 1,00 | 0,39 | 0,28 | 0,11 | 0,47 | 0,18 | 0,64 | 0,25 | 0,81 | 0,32 |
| 6 | 19,7 | 2,00 | 0,79 | 0,50 | 0,20 | 0,82 | 0,32 | 1,12 | 0,44 | 1,41 | 0,56 |
| 7 | 23,0 | 2,33 | 0,92 | 0,81 | 0,32 | 1,31 | 0,52 | 1,79 | 0,70 | 2,25 | 0,89 |
| 8 | 26,2 | 2,67 | 1,05 | 1,22 | 0,48 | 1,98 | 0,78 | 2,67 | 1,05 | 2,67 | 1,05 |
| 9 | 29,5 | 3,00 | 1,18 | 1,77 | 0,70 | 2,84 | 1,12 | 3,00 | 1,18 | 3,00 | 1,18 |
| 10 | 32,8 | 3,33 | 1,31 | 2,47 | 0,97 | 3,33 | 1,31 | 3,33 | 1,31 | 3,33 | 1,31 |
| 11 | 36,1 | 3,67 | 1,44 | 3,34 | 1,31 | 3,67 | 1,44 | 3,67 | 1,44 | 3,67 | 1,44 |
| 12 | 39,4 | 4,00 | 1,57 | 4,00 | 1,57 | 4,00 | 1,57 | 4,00 | 1,57 | 4,00 | 1,57 |
| 13 | 42,7 | 4,33 | 1,71 | 4,33 | 1,71 | 4,33 | 1,71 | 4,33 | 1,71 | 4,33 | 1,71 |
| 14 | 45,9 | 4,67 | 1,84 | 4,67 | 1,84 | 4,67 | 1,84 | 4,67 | 1,84 | 4,67 | 1,84 |
| 15 | 49,2 | 5,00 | 1,97 | 5,00 | 1,97 | 5,00 | 1,97 | 5,00 | 1,97 | 5,00 | 1,97 |
| 16 | 52,5 | 5,33 | 2,10 | 5,33 | 2,10 | 5,33 | 2,10 | 5,33 | 2,10 | 5,33 | 2,10 |
| 17 | 55,8 | 5,67 | 2,23 | 5,67 | 2,23 | 5,67 | 2,23 | 5,67 | 2,23 | 5,67 | 2,23 |
| 18 | 59,1 | 6,00 | 2,36 | 6,00 | 2,36 | 6,00 | 2,36 | 6,00 | 2,36 | 6,00 | 2,36 |
| 19 | 62,3 | 6,33 | 2,49 | 6,33 | 2,49 | 6,33 | 2,49 | 6,33 | 2,49 | 6,33 | 2,49 |
| 20 | 65,6 | 6,67 | 2,62 | 6,67 | 2,62 | 6,67 | 2,62 | 6,67 | 2,62 | 6,67 | 2,62 |

6.4 Deflections at max. allowable loadings on side chords (LC2):

6.4.1 Limitation of deflection = L/100

Deflections [cm] for F45 at max. allowable loading on the side chords

Vorhandene Durchbiegung [cm] F45 unter max. zul. Lasten

| Span | | UDL | | Einzellasten/ Single point loads | | | | | | | |
|------|------|-------|--------|----------------------------------|--------|---------------|--------|---------------|--------|---------------|--------|
| | | | | in 1/2 Point | | in 1/3 Points | | in 1/4 Points | | in 1/5 Points | |
| [m] | [ft] | [cm] | [inch] | [cm] | [inch] | [cm] | [inch] | [cm] | [inch] | [cm] | [inch] |
| 4 | 13,1 | 0,65 | 0,25 | 0,60 | 0,24 | 0,63 | 0,25 | 0,67 | 0,26 | 0,70 | 0,28 |
| 5 | 16,4 | 1,26 | 0,50 | 1,00 | 0,39 | 1,08 | 0,43 | 1,18 | 0,46 | 1,25 | 0,49 |
| 6 | 19,7 | 2,18 | 0,86 | 1,52 | 0,60 | 1,67 | 0,66 | 1,84 | 0,72 | 1,91 | 0,75 |
| 7 | 23,0 | 3,05 | 1,20 | 2,14 | 0,84 | 2,39 | 0,94 | 2,66 | 1,05 | 2,69 | 1,06 |
| 8 | 26,2 | 4,05 | 1,60 | 2,88 | 1,13 | 3,26 | 1,28 | 3,65 | 1,44 | 3,60 | 1,42 |
| 9 | 29,5 | 5,19 | 2,05 | 3,73 | 1,47 | 4,26 | 1,68 | 4,68 | 1,84 | 4,66 | 1,83 |
| 10 | 32,8 | 6,47 | 2,55 | 4,71 | 1,85 | 5,41 | 2,13 | 5,85 | 2,30 | 5,85 | 2,30 |
| 11 | 36,1 | 7,89 | 3,11 | 5,80 | 2,28 | 6,70 | 2,64 | 7,16 | 2,82 | 7,19 | 2,83 |
| 12 | 39,4 | 9,44 | 3,72 | 7,02 | 2,76 | 8,13 | 3,20 | 8,60 | 3,39 | 8,67 | 3,41 |
| 13 | 42,7 | 11,14 | 4,38 | 8,36 | 3,29 | 9,72 | 3,83 | 10,18 | 4,01 | 10,29 | 4,05 |
| 14 | 45,9 | 12,97 | 5,11 | 9,84 | 3,87 | 11,45 | 4,51 | 11,90 | 4,68 | 12,07 | 4,75 |
| 15 | 49,2 | 14,95 | 5,89 | 11,45 | 4,51 | 13,35 | 5,25 | 13,76 | 5,42 | 13,98 | 5,51 |
| 16 | 52,5 | 16,00 | 6,30 | 13,20 | 5,20 | 15,40 | 6,06 | 15,77 | 6,21 | 16,00 | 6,30 |
| 17 | 55,8 | 17,00 | 6,69 | 15,10 | 5,94 | 17,00 | 6,69 | 17,00 | 6,69 | 17,00 | 6,69 |
| 18 | 59,1 | 18,00 | 7,09 | 17,14 | 6,75 | 18,00 | 7,09 | 18,00 | 7,09 | 18,00 | 7,09 |
| 19 | 62,3 | 19,00 | 7,48 | 19,00 | 7,48 | 19,00 | 7,48 | 19,00 | 7,48 | 19,00 | 7,48 |
| 20 | 65,6 | 20,00 | 7,87 | 20,00 | 7,87 | 20,00 | 7,87 | 20,00 | 7,87 | 20,00 | 7,87 |
| 21 | 68,9 | 21,00 | 8,27 | 21,00 | 8,27 | 21,00 | 8,27 | 21,00 | 8,27 | 21,00 | 8,27 |
| 22 | 72,2 | 22,00 | 8,66 | 22,00 | 8,66 | 22,00 | 8,66 | 22,00 | 8,66 | 22,00 | 8,66 |
| 23 | 75,5 | 23,00 | 9,06 | 23,00 | 9,06 | 23,00 | 9,06 | 23,00 | 9,06 | 23,00 | 9,06 |
| 24 | 78,7 | 24,00 | 9,45 | 24,00 | 9,45 | 24,00 | 9,45 | 24,00 | 9,45 | 24,00 | 9,45 |



6.4.2 Limitation of deflection = L/200

Deflections [cm] for F45 at max. allowable loading on the side chords

Vorhandene Durchbiegung [cm] F45 unter max. zul. Lasten

| Span | | UDL | | Einzellasten / Single point loads | | | | | | | |
|------|------|-------|--------|-----------------------------------|--------|---------------|--------|---------------|--------|---------------|--------|
| | | [cm] | [inch] | in 1/2 Point | | in 1/3 Points | | in 1/4 Points | | in 1/5 Points | |
| [m] | [ft] | [cm] | [inch] | [cm] | [inch] | [cm] | [inch] | [cm] | [inch] | [cm] | [inch] |
| 4 | 13,1 | 0,65 | 0,25 | 0,60 | 0,24 | 0,63 | 0,25 | 0,67 | 0,26 | 0,70 | 0,28 |
| 5 | 16,4 | 1,26 | 0,50 | 1,00 | 0,39 | 1,08 | 0,43 | 1,18 | 0,46 | 1,25 | 0,49 |
| 6 | 19,7 | 2,18 | 0,86 | 1,52 | 0,60 | 1,67 | 0,66 | 1,84 | 0,72 | 1,91 | 0,75 |
| 7 | 23,0 | 3,05 | 1,20 | 2,14 | 0,84 | 2,39 | 0,94 | 2,66 | 1,05 | 2,69 | 1,06 |
| 8 | 26,2 | 4,00 | 1,57 | 2,88 | 1,13 | 3,26 | 1,28 | 3,65 | 1,44 | 3,60 | 1,42 |
| 9 | 29,5 | 4,50 | 1,77 | 3,73 | 1,47 | 4,26 | 1,68 | 4,50 | 1,77 | 4,50 | 1,77 |
| 10 | 32,8 | 5,00 | 1,97 | 4,71 | 1,85 | 5,00 | 1,97 | 5,00 | 1,97 | 5,00 | 1,97 |
| 11 | 36,1 | 5,50 | 2,17 | 5,50 | 2,17 | 5,50 | 2,17 | 5,50 | 2,17 | 5,50 | 2,17 |
| 12 | 39,4 | 6,00 | 2,36 | 6,00 | 2,36 | 6,00 | 2,36 | 6,00 | 2,36 | 6,00 | 2,36 |
| 13 | 42,7 | 6,50 | 2,56 | 6,50 | 2,56 | 6,50 | 2,56 | 6,50 | 2,56 | 6,50 | 2,56 |
| 14 | 45,9 | 7,00 | 2,76 | 7,00 | 2,76 | 7,00 | 2,76 | 7,00 | 2,76 | 7,00 | 2,76 |
| 15 | 49,2 | 7,50 | 2,95 | 7,50 | 2,95 | 7,50 | 2,95 | 7,50 | 2,95 | 7,50 | 2,95 |
| 16 | 52,5 | 8,00 | 3,15 | 8,00 | 3,15 | 8,00 | 3,15 | 8,00 | 3,15 | 8,00 | 3,15 |
| 17 | 55,8 | 8,50 | 3,35 | 8,50 | 3,35 | 8,50 | 3,35 | 8,50 | 3,35 | 8,50 | 3,35 |
| 18 | 59,1 | 9,00 | 3,54 | 9,00 | 3,54 | 9,00 | 3,54 | 9,00 | 3,54 | 9,00 | 3,54 |
| 19 | 62,3 | 9,50 | 3,74 | 9,50 | 3,74 | 9,50 | 3,74 | 9,50 | 3,74 | 9,50 | 3,74 |
| 20 | 65,6 | 10,00 | 3,94 | 10,00 | 3,94 | 10,00 | 3,94 | 10,00 | 3,94 | 10,00 | 3,94 |
| 21 | 68,9 | 10,50 | 4,13 | 10,50 | 4,13 | 10,50 | 4,13 | 10,50 | 4,13 | 10,50 | 4,13 |
| 22 | 72,2 | 11,00 | 4,33 | 11,00 | 4,33 | 11,00 | 4,33 | 11,00 | 4,33 | 11,00 | 4,33 |

6.4.3 Limitation of deflection = L/300

Deflections [cm] for F45 at max. allowable loading on the side chords

Vorhandene Durchbiegung [cm] F45 unter max. zul. Lasten

| Span | | UDL | | Einzellasten / Single point loads | | | | | | | |
|------|------|------|--------|-----------------------------------|--------|---------------|--------|---------------|--------|---------------|--------|
| | | [cm] | [inch] | in 1/2 Point | | in 1/3 Points | | in 1/4 Points | | in 1/5 Points | |
| [m] | [ft] | [cm] | [inch] | [cm] | [inch] | [cm] | [inch] | [cm] | [inch] | [cm] | [inch] |
| 4 | 13,1 | 0,65 | 0,25 | 0,60 | 0,24 | 0,63 | 0,25 | 0,67 | 0,26 | 0,70 | 0,28 |
| 5 | 16,4 | 1,26 | 0,50 | 1,00 | 0,39 | 1,08 | 0,43 | 1,18 | 0,46 | 1,25 | 0,49 |
| 6 | 19,7 | 2,00 | 0,79 | 1,52 | 0,60 | 1,67 | 0,66 | 1,84 | 0,72 | 1,91 | 0,75 |
| 7 | 23,0 | 2,33 | 0,92 | 2,14 | 0,84 | 2,33 | 0,92 | 2,33 | 0,92 | 2,33 | 0,92 |
| 8 | 26,2 | 2,67 | 1,05 | 2,67 | 1,05 | 2,67 | 1,05 | 2,67 | 1,05 | 2,67 | 1,05 |
| 9 | 29,5 | 3,00 | 1,18 | 3,00 | 1,18 | 3,00 | 1,18 | 3,00 | 1,18 | 3,00 | 1,18 |
| 10 | 32,8 | 3,33 | 1,31 | 3,33 | 1,31 | 3,33 | 1,31 | 3,33 | 1,31 | 3,33 | 1,31 |
| 11 | 36,1 | 3,67 | 1,44 | 3,67 | 1,44 | 3,67 | 1,44 | 3,67 | 1,44 | 3,67 | 1,44 |
| 12 | 39,4 | 4,00 | 1,57 | 4,00 | 1,57 | 4,00 | 1,57 | 4,00 | 1,57 | 4,00 | 1,57 |
| 13 | 42,7 | 4,33 | 1,71 | 4,33 | 1,71 | 4,33 | 1,71 | 4,33 | 1,71 | 4,33 | 1,71 |
| 14 | 45,9 | 4,67 | 1,84 | 4,67 | 1,84 | 4,67 | 1,84 | 4,67 | 1,84 | 4,67 | 1,84 |
| 15 | 49,2 | 5,00 | 1,97 | 5,00 | 1,97 | 5,00 | 1,97 | 5,00 | 1,97 | 5,00 | 1,97 |
| 16 | 52,5 | 5,33 | 2,10 | 5,33 | 2,10 | 5,33 | 2,10 | 5,33 | 2,10 | 5,33 | 2,10 |
| 17 | 55,8 | 5,67 | 2,23 | 5,67 | 2,23 | 5,67 | 2,23 | 5,67 | 2,23 | 5,67 | 2,23 |
| 18 | 59,1 | 6,00 | 2,36 | 6,00 | 2,36 | 6,00 | 2,36 | 6,00 | 2,36 | 6,00 | 2,36 |
| 19 | 62,3 | 6,33 | 2,49 | 6,33 | 2,49 | 6,33 | 2,49 | 6,33 | 2,49 | 6,33 | 2,49 |
| 20 | 65,6 | 6,67 | 2,62 | 6,67 | 2,62 | 6,67 | 2,62 | 6,67 | 2,62 | 6,67 | 2,62 |

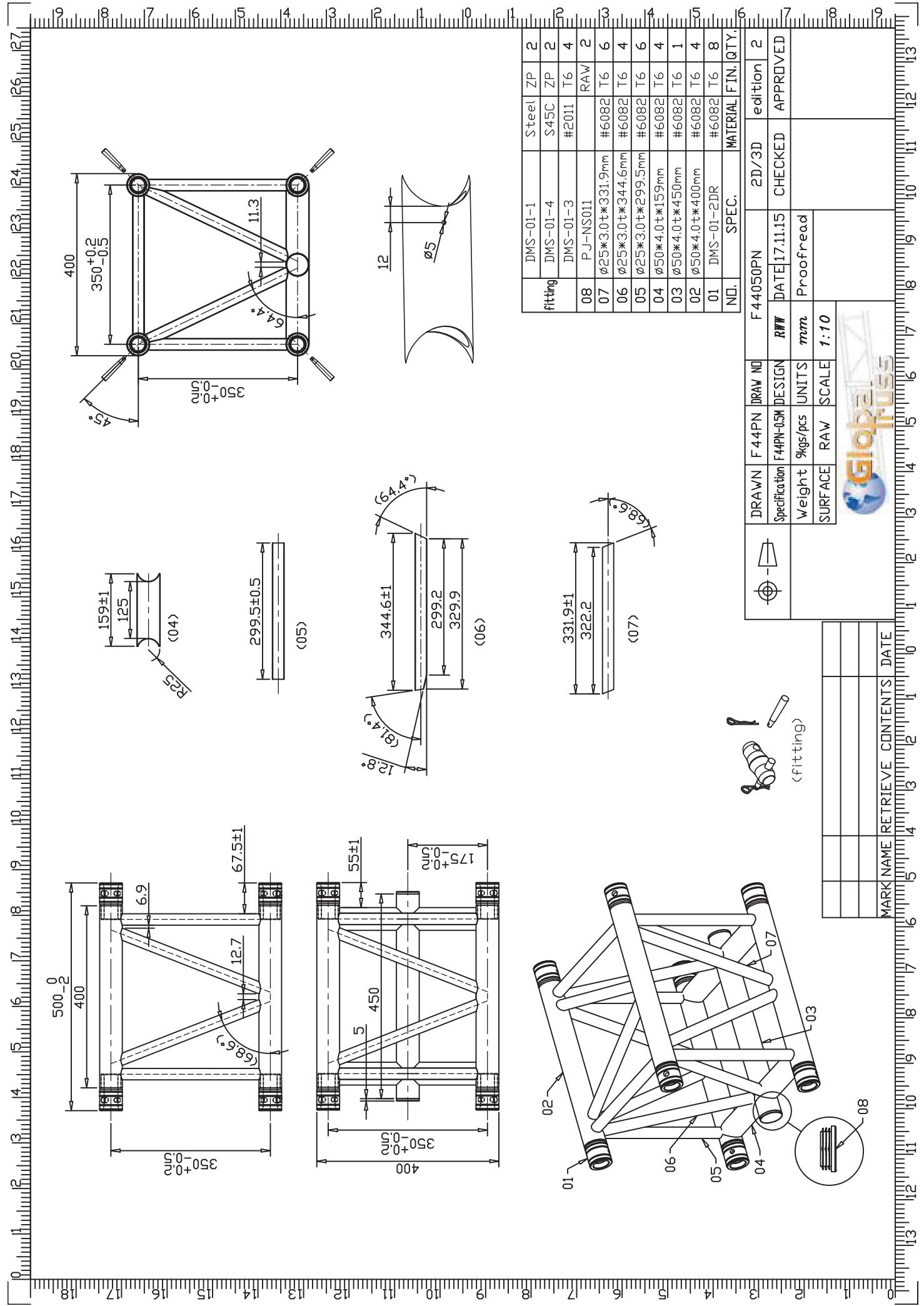

| | | | | |
|---------|------------------|--------------------|-----|---|
| fitting | DMS-01-1 | Steel | ZP | 2 |
| | DMS-01-4 | S45C | ZP | 2 |
| | DMS-01-3 | #2011 | T6 | 4 |
| 08 | PJ-NS011 | | RAW | 2 |
| 07 | ø25*3.0t*331.9mm | #6082 | T6 | 6 |
| 06 | ø25*3.0t*344.6mm | #6082 | T6 | 4 |
| 05 | ø25*3.0t*299.5mm | #6082 | T6 | 6 |
| 04 | ø50*4.0t*159mm | #6082 | T6 | 4 |
| 03 | ø50*4.0t*450mm | #6082 | T6 | 1 |
| 02 | ø50*4.0t*400mm | #6082 | T6 | 4 |
| 01 | DMS-01-2DR | #6082 | T6 | 8 |
| Nil. | SPEC. | MATERIAL FIN. QTY. | | |

| | | | | | | | |
|--|---------------|-----------|---------|-----------|-----------|---------|----------|
| | DRAWN | F 44PN | DRAW NO | F 44050PN | 2D/3D | edition | 2 |
| | Specification | F44PN-05M | DESIGN | DATE | 17.11.15 | CHECKED | APPROVED |
| | Weight | %kgs/pcs | UNITS | mm | Proofread | | |
| | SURFACE | RAW | SCALE | 1:10 | | | |

| | | | | |
|--|-----------|----------|----------|------|
| | MARK NAME | RETRIEVE | CONTENTS | DATE |
| | | | | |
| | | | | |
| | | | | |



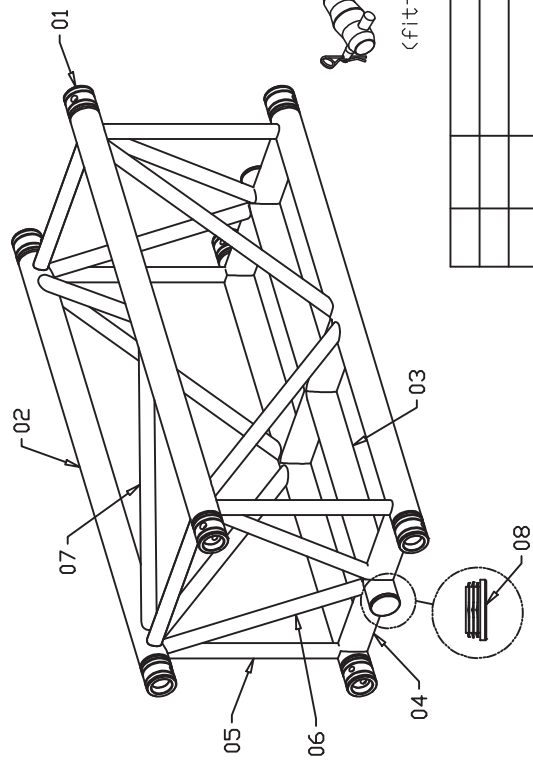
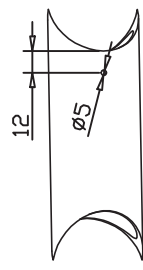
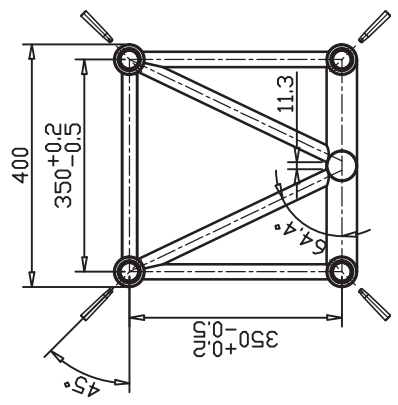
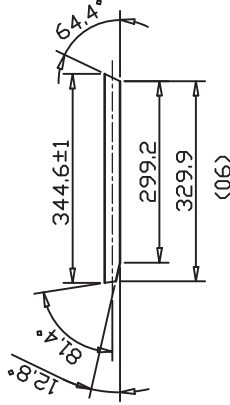
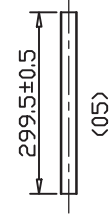
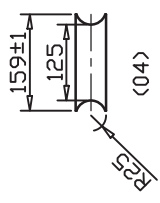
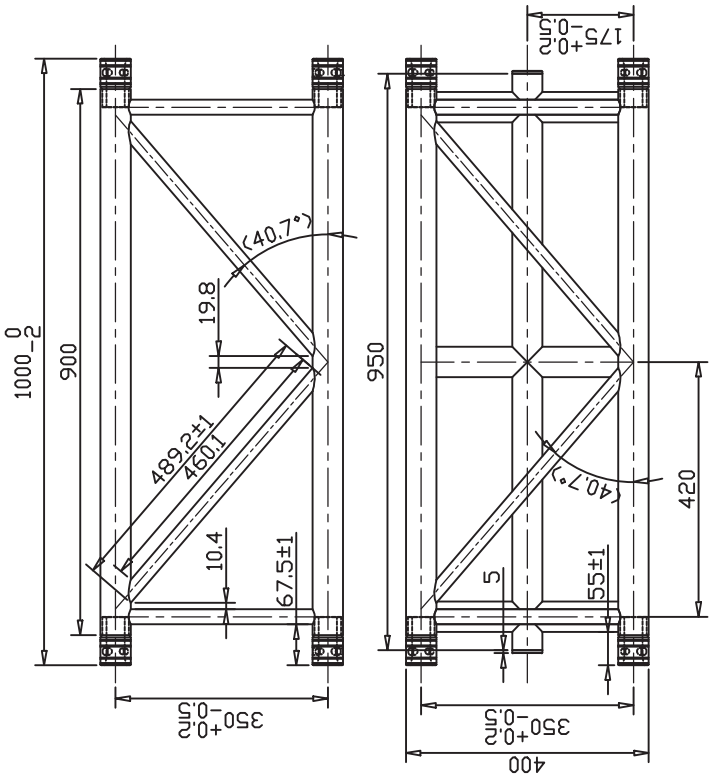

| | | | | |
|---------|------------------|--------------------|-----|---|
| fitting | DMS-01-1 | Steel | ZP | 8 |
| | DMS-01-4 | S45C | ZP | 8 |
| | DMS-01-3 | #2011 | T6 | 4 |
| 08 | PJ-NS011 | | RAW | 2 |
| 07 | ø25*3.0t*489.2mm | #6082 | T6 | 6 |
| 06 | ø25*3.0t*344.6mm | #6082 | T6 | 4 |
| 05 | ø25*3.0t*299.5mm | #6082 | T6 | 6 |
| 04 | ø50*4.0t*159mm | #6082 | T6 | 6 |
| 03 | ø50*4.0t*950mm | #6082 | T6 | 1 |
| 02 | ø50*4.0t*900mm | #6082 | T6 | 4 |
| 01 | DMS-01-2DR | #6082 | T6 | 8 |
| N.D. | SPEC. | MATERIAL FIN. QTY. | | |

| | | | | | | | |
|--|---------------|-------------|--------|-----------|-----------|---------|----------|
| | DRAWN | F 44PN | DRW NO | F 44100PN | 2D/3D | edition | 1 |
| | Specification | F44PN-10M | DESIGN | DATE | 17.11.15 | CHECKED | APPROVED |
| | Weight | 14.4kgs/pcs | UNITS | mm | Proofread | | |
| | SURFACE | RAW | SCALE | 1:12 | | | |



| | | | |
|-----------|----------|----------|------|
| MARK NAME | RETRIEVE | CONTENTS | DATE |
| | | | |
| | | | |
| | | | |
| | | | |

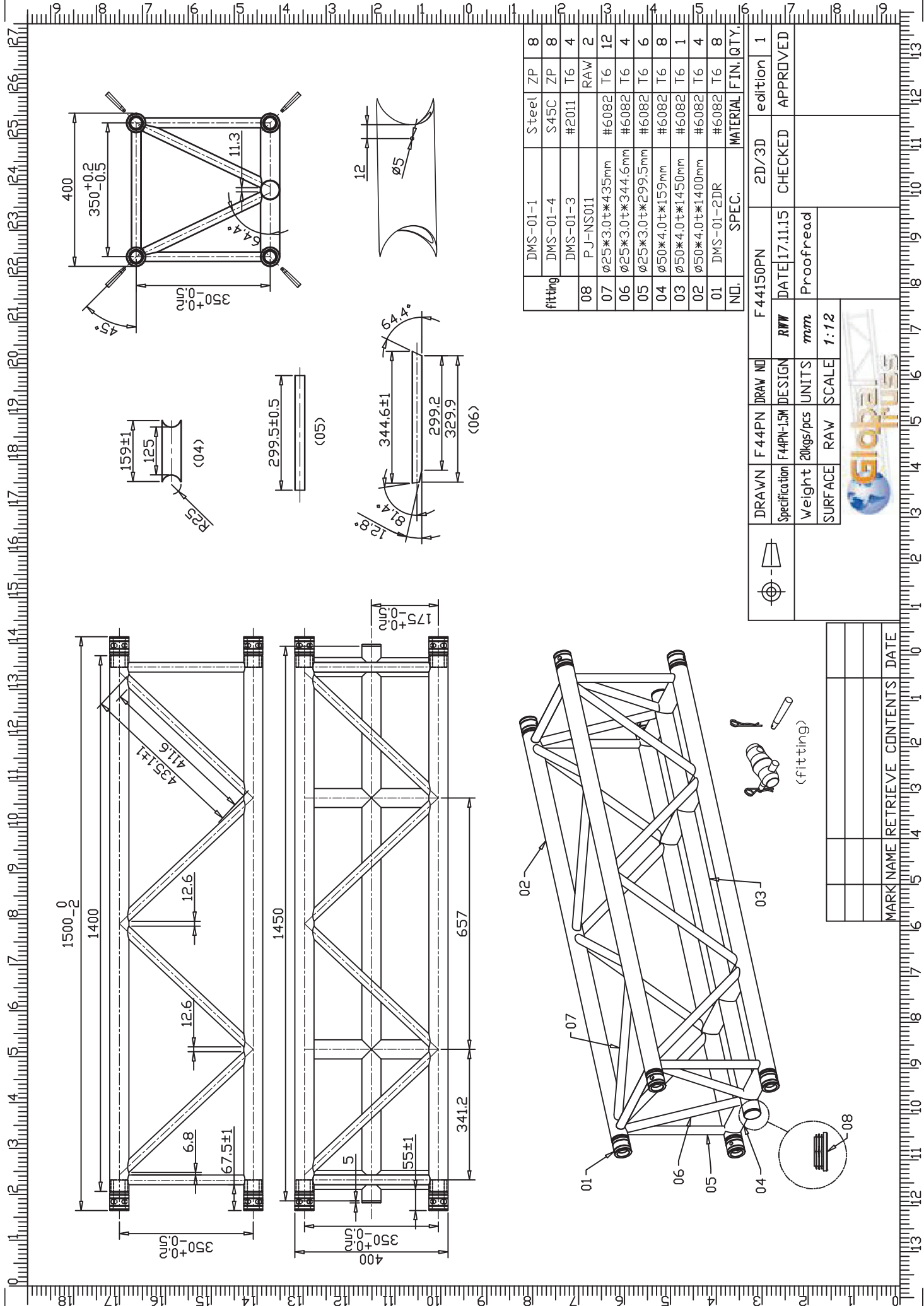

| | | | | |
|---------|------------------|--------------------|-----|----|
| fitting | DMS-01-1 | Steel | ZP | 8 |
| | DMS-01-4 | S45C | ZP | 8 |
| | DMS-01-3 | #2011 | T6 | 4 |
| 08 | PJ-NS011 | | RAW | 2 |
| 07 | ø25*3.0t*435mm | #6082 | T6 | 12 |
| 06 | ø25*3.0t*344.6mm | #6082 | T6 | 4 |
| 05 | ø25*3.0t*299.5mm | #6082 | T6 | 6 |
| 04 | ø50*4.0t*159mm | #6082 | T6 | 8 |
| 03 | ø50*4.0t*1450mm | #6082 | T6 | 1 |
| 02 | ø50*4.0t*1400mm | #6082 | T6 | 4 |
| 01 | DMS-01-2DR | #6082 | T6 | 8 |
| N.D. | SPEC. | MATERIAL FIN. QTY. | | |

| | | | | | | | |
|--|---------------|-----------|---------|-----------|-----------|---------|----------|
| | DRAWN | F 44PN | DRAW NO | F 44150PN | 2D/3D | edition | 1 |
| | Specification | F44PN-15M | DESIGN | DATE | 17.11.15 | CHECKED | APPROVED |
| | Weight | 20kgs/pcs | UNITS | mm | Proofread | | |
| | SURFACE | RAW | SCALE | 1:12 | | | |

| | | | | |
|------|------|----------|----------|------|
| MARK | NAME | RETRIEVE | CONTENTS | DATE |
| | | | | |
| | | | | |
| | | | | |



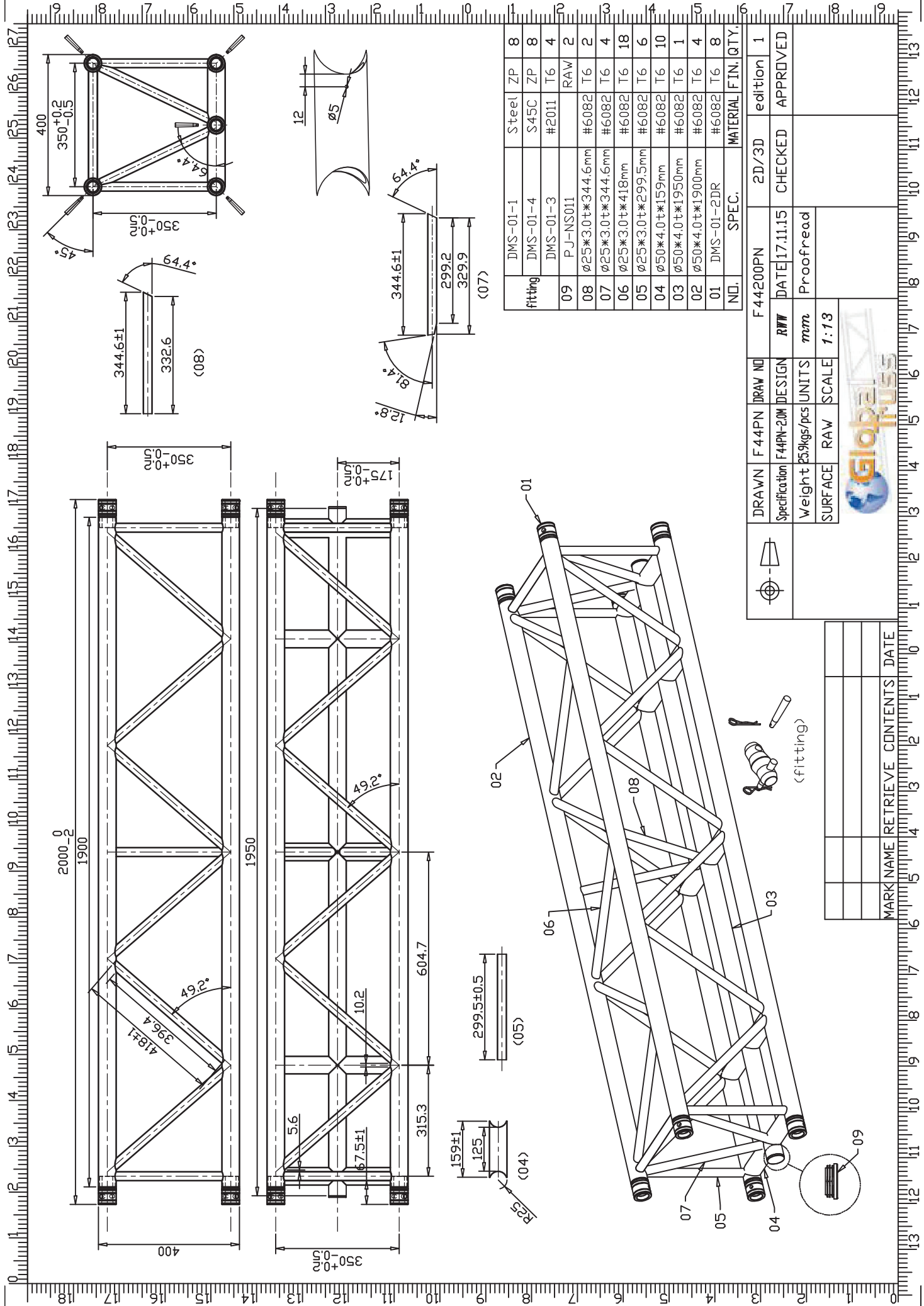

| | | | | |
|---------|------------------|-------|-----|----|
| fitting | DMS-01-1 | Steel | ZP | 8 |
| | DMS-01-4 | S45C | ZP | 8 |
| | DMS-01-3 | #2011 | T6 | 4 |
| 09 | PJ-NS011 | | RAW | 2 |
| 08 | ø25*3.0t*344.6mm | #6082 | T6 | 2 |
| 07 | ø25*3.0t*418mm | #6082 | T6 | 4 |
| 06 | ø25*3.0t*418mm | #6082 | T6 | 18 |
| 05 | ø25*3.0t*299.5mm | #6082 | T6 | 6 |
| 04 | ø50*4.0t*159mm | #6082 | T6 | 10 |
| 03 | ø50*4.0t*1950mm | #6082 | T6 | 1 |
| 02 | ø50*4.0t*1900mm | #6082 | T6 | 4 |
| 01 | DMS-01-2DR | #6082 | T6 | 8 |

| | | | | | | |
|---------------|------------|--------|-----------|-----------|---------|----------|
| DRAWN | F 44PN | DRW NO | F 44200PN | 2D/3D | edition | 1 |
| Specification | F44PN-20M | DESIGN | DATE | 17.11.15 | CHECKED | APPROVED |
| Weight | 259kgs/pcs | UNITS | mm | Proofread | | |
| SURFACE | RAW | SCALE | 1:13 | | | |

| | | | |
|-----------|----------|----------|------|
| MARK NAME | RETRIEVE | CONTENTS | DATE |
| | | | |
| | | | |
| | | | |



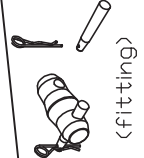
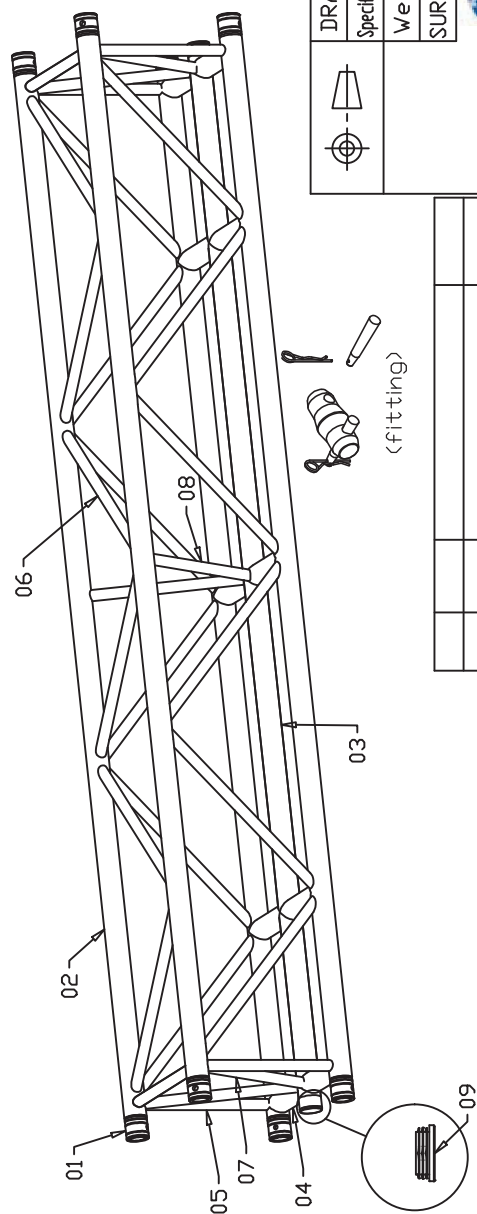
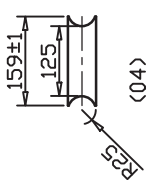
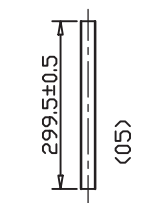
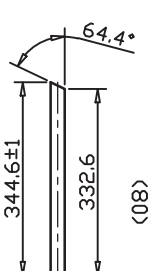
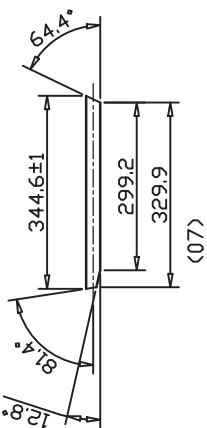
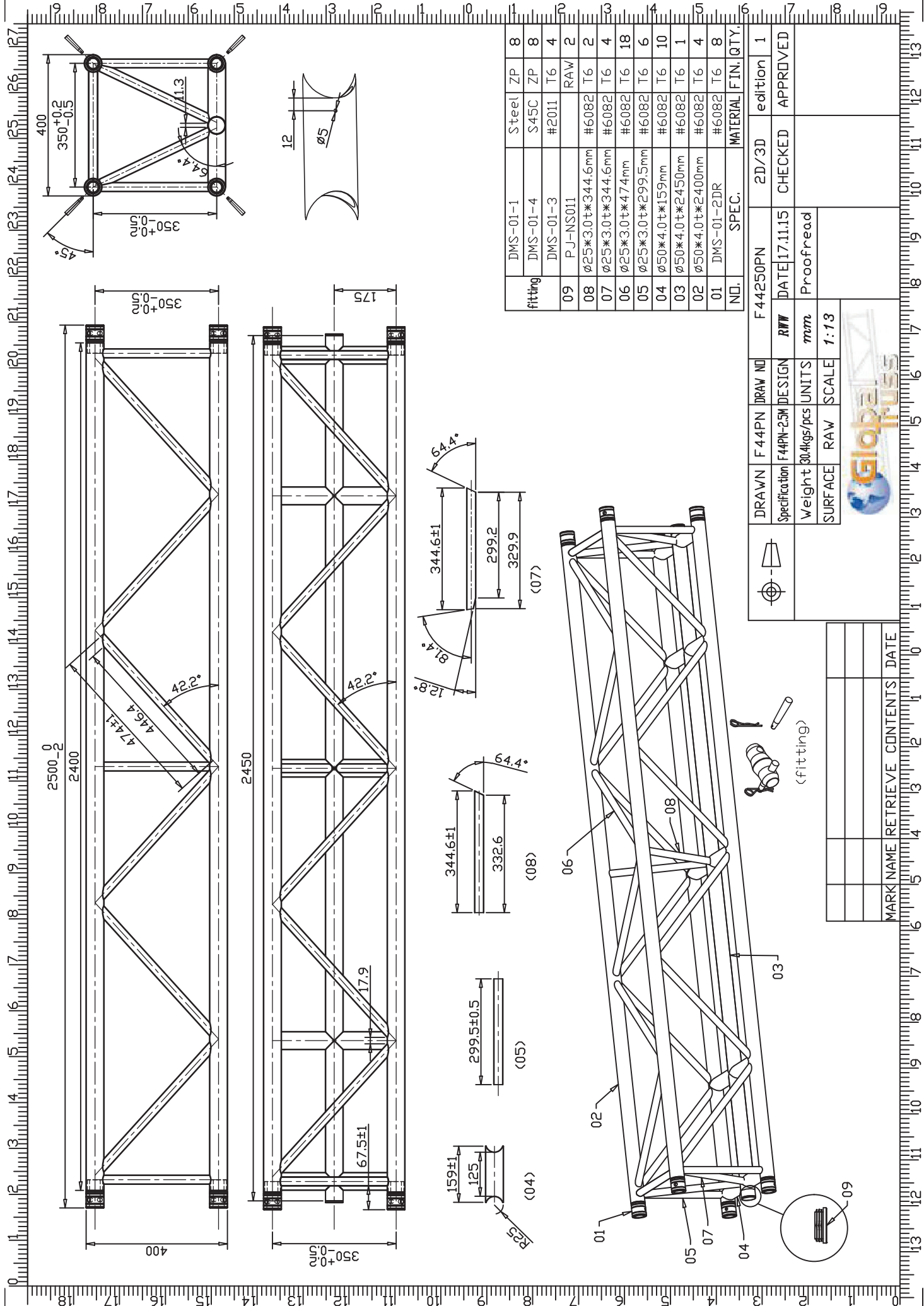

| | | | | |
|---------|------------------|--------------------|-----|----|
| fitting | DMS-01-1 | Steel | ZP | 8 |
| | DMS-01-4 | S45C | ZP | 8 |
| | DMS-01-3 | #2011 | T6 | 4 |
| 09 | PJ-NS011 | | RAW | 2 |
| 08 | ø25*3.0t*344.6mm | #6082 | T6 | 2 |
| 07 | ø25*3.0t*344.6mm | #6082 | T6 | 4 |
| 06 | ø25*3.0t*299.5mm | #6082 | T6 | 18 |
| 05 | ø25*3.0t*299.5mm | #6082 | T6 | 6 |
| 04 | ø50*4.0t*159mm | #6082 | T6 | 10 |
| 03 | ø50*4.0t*2450mm | #6082 | T6 | 1 |
| 02 | ø50*4.0t*2400mm | #6082 | T6 | 4 |
| 01 | DMS-01-2DR | #6082 | T6 | 8 |
| NIJ. | SPEC. | MATERIAL FIN. QTY. | | |

| | | | | | | | |
|--|---------------|-------------|---------|-----------|-----------|---------|----------|
| | DRAWN | F 44PN | DRAW NO | F 44250PN | 2D/3D | edition | 1 |
| | Specification | F44PN-25M | DESIGN | DATE | 17.11.15 | CHECKED | APPROVED |
| | Weight | 30.4kgs/pcs | UNITS | mm | Proofread | | |
| | SURFACE | RAW | SCALE | 1:13 | | | |

| | | | | |
|--|-----------|----------|----------|------|
| | MARK NAME | RETRIEVE | CONTENTS | DATE |
| | | | | |
| | | | | |
| | | | | |



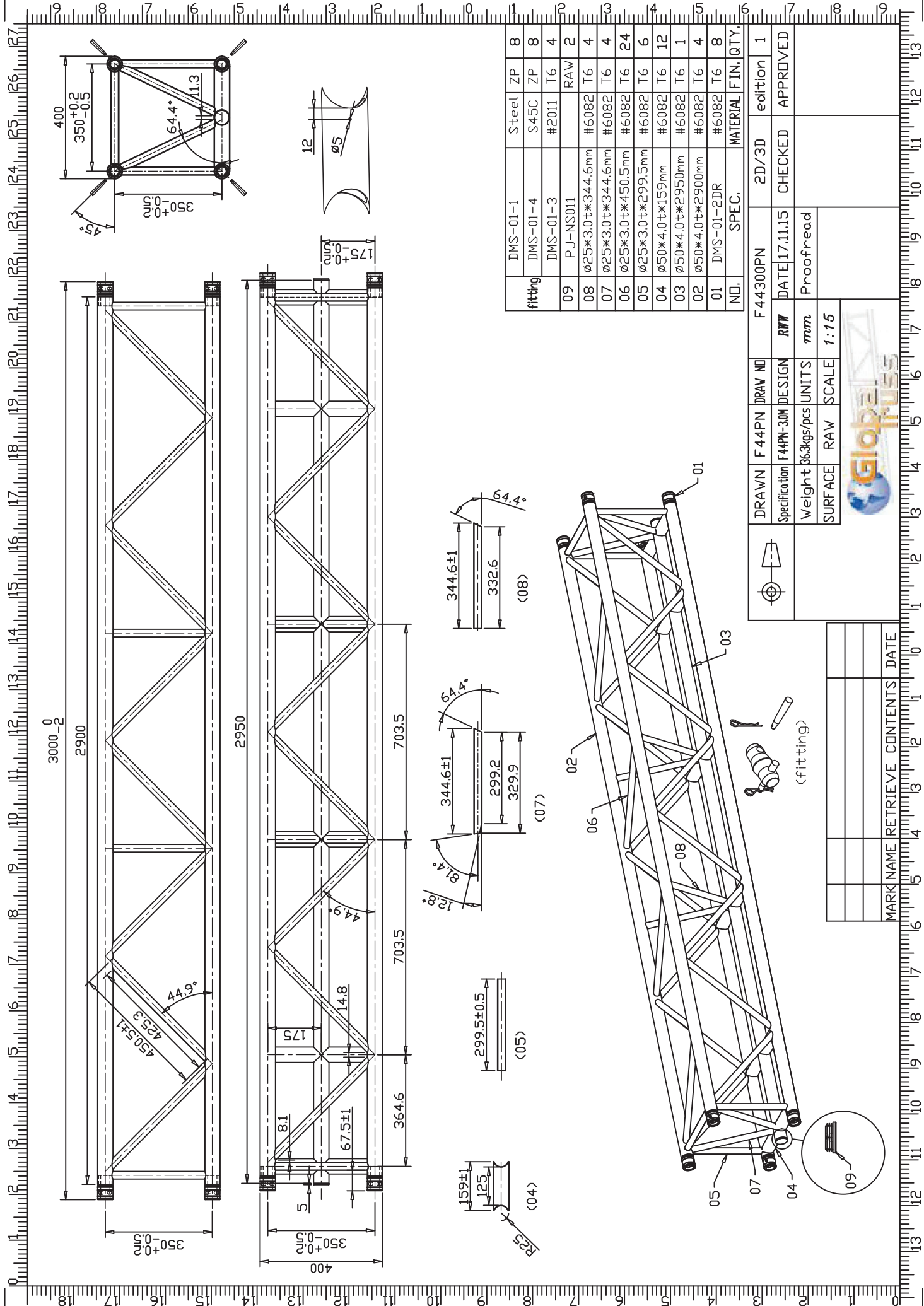

| | | | | |
|---------|------------------|--------------------|-----|----|
| fitting | DMS-01-1 | Steel | ZP | 8 |
| | DMS-01-4 | S45C | ZP | 8 |
| | DMS-01-3 | #2011 | T6 | 4 |
| 09 | PJ-NS011 | | RAW | 2 |
| 08 | ø25*3.0t*344.6mm | #6082 | T6 | 4 |
| 07 | ø25*3.0t*344.6mm | #6082 | T6 | 4 |
| 06 | ø25*3.0t*450.5mm | #6082 | T6 | 24 |
| 05 | ø25*3.0t*299.5mm | #6082 | T6 | 6 |
| 04 | ø50*4.0t*159mm | #6082 | T6 | 12 |
| 03 | ø50*4.0t*2950mm | #6082 | T6 | 1 |
| 02 | ø50*4.0t*2900mm | #6082 | T6 | 4 |
| 01 | DMS-01-2DR | #6082 | T6 | 8 |
| N.D. | SPEC. | MATERIAL FIN. QTY. | | |

| | | | | | |
|--|---------------|-------------|--------|---------|-----------|
| | DRAWN | F 44300PN | 2D/3D | edition | 1 |
| | Specification | F44PN-30M | DESIGN | DATE | 17.11.15 |
| | Weight | 86.3kgs/pcs | UNITS | mm | Proofread |
| | SURFACE | RAW | SCALE | 1:15 | |

| | | | | |
|--|-----------|----------|----------|------|
| | MARK NAME | RETRIEVE | CONTENTS | DATE |
| | | | | |
| | | | | |
| | | | | |



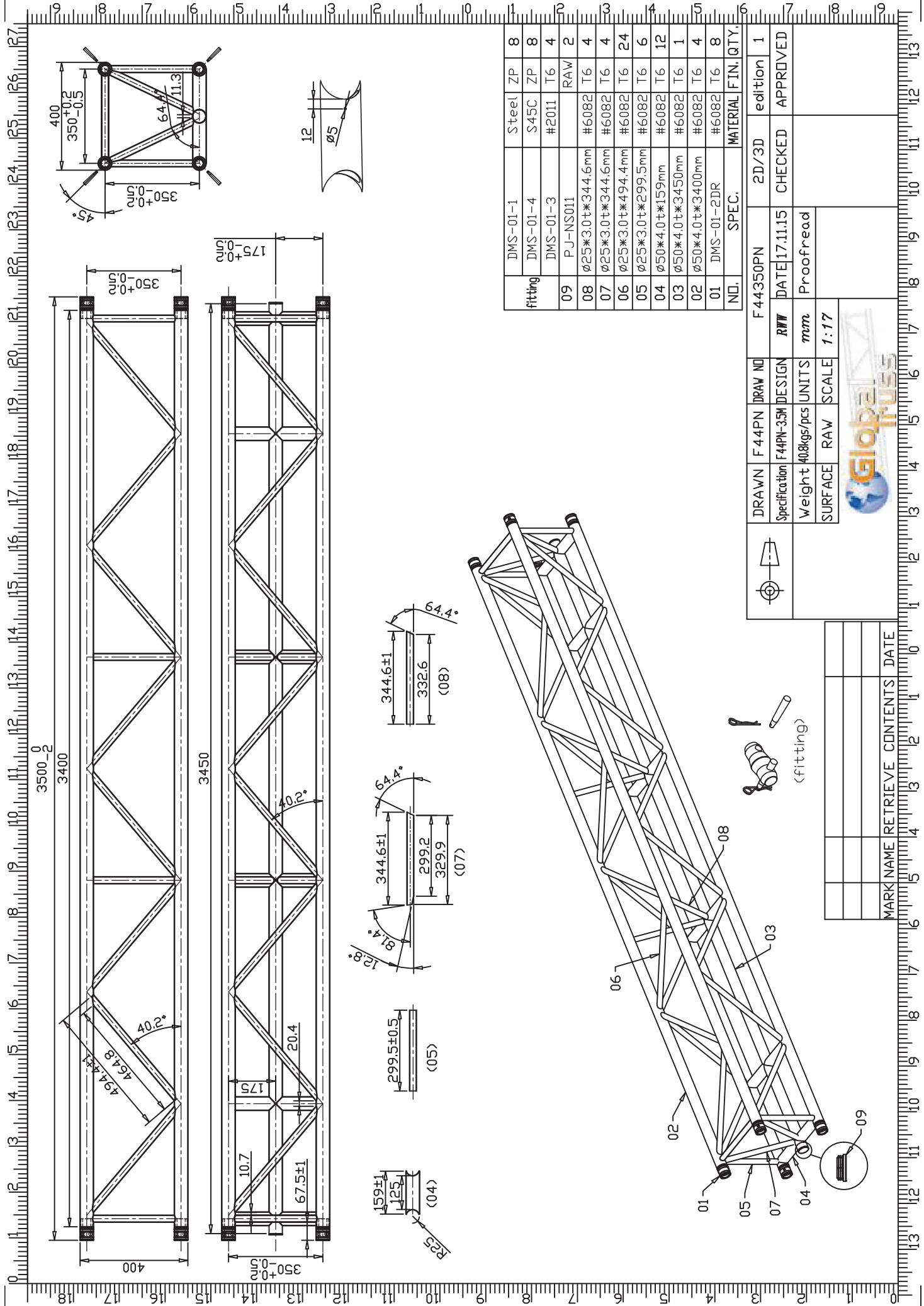

| | | | | |
|---------|------------------|--------------------|-----|----|
| fitting | DMS-01-1 | Steel | ZP | 8 |
| | DMS-01-4 | S45C | ZP | 8 |
| | DMS-01-3 | #2011 | T6 | 4 |
| 09 | PJ-NS011 | | RAW | 2 |
| 08 | Ø25*3.0t*344.6mm | #6082 | T6 | 4 |
| 07 | Ø25*3.0t*344.6mm | #6082 | T6 | 4 |
| 06 | Ø25*3.0t*299.5mm | #6082 | T6 | 6 |
| 04 | Ø50*4.0t*159mm | #6082 | T6 | 12 |
| 03 | Ø50*4.0t*3450mm | #6082 | T6 | 1 |
| 02 | Ø50*4.0t*3400mm | #6082 | T6 | 4 |
| 01 | DMS-01-2DR | #6082 | T6 | 8 |
| N/D. | SPEC. | MATERIAL FIN. QTY. | | |

| | | | | | | | | |
|--|---------------|------------|---------|-----------|-----------|----------|---------|----------|
| | DRAWN | F 44PN | DRAW NO | F 44350PN | 2D/3D | edition | 1 | |
| | Specification | F44PN-35M | DESIGN | RWW | DATE | 17.11.15 | CHECKED | APPROVED |
| | Weight | 408kgs/pcs | UNITS | m | Proofread | | | |
| | SURFACE | RAW | SCALE | 1:17 | | | | |



| | | | |
|-----------|----------|----------|------|
| MARK NAME | RETRIEVE | CONTENTS | DATE |
| | | | |
| | | | |
| | | | |

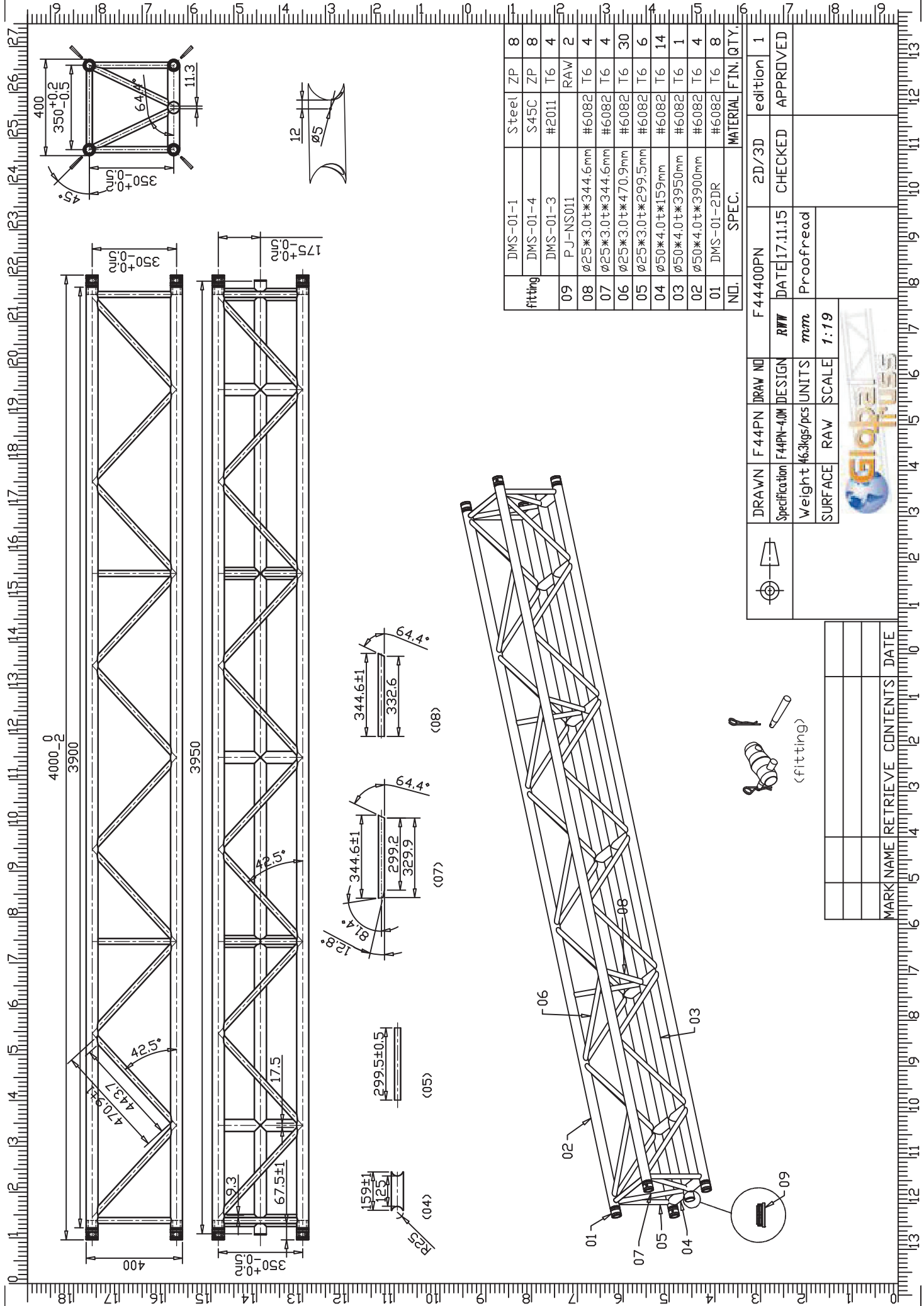

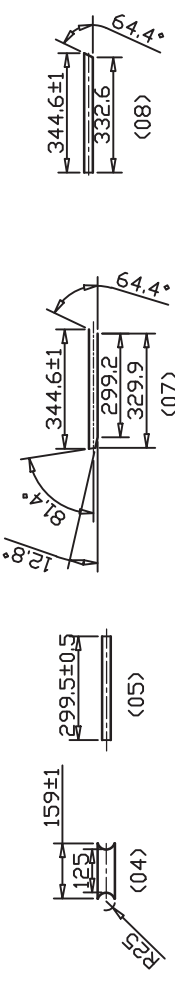
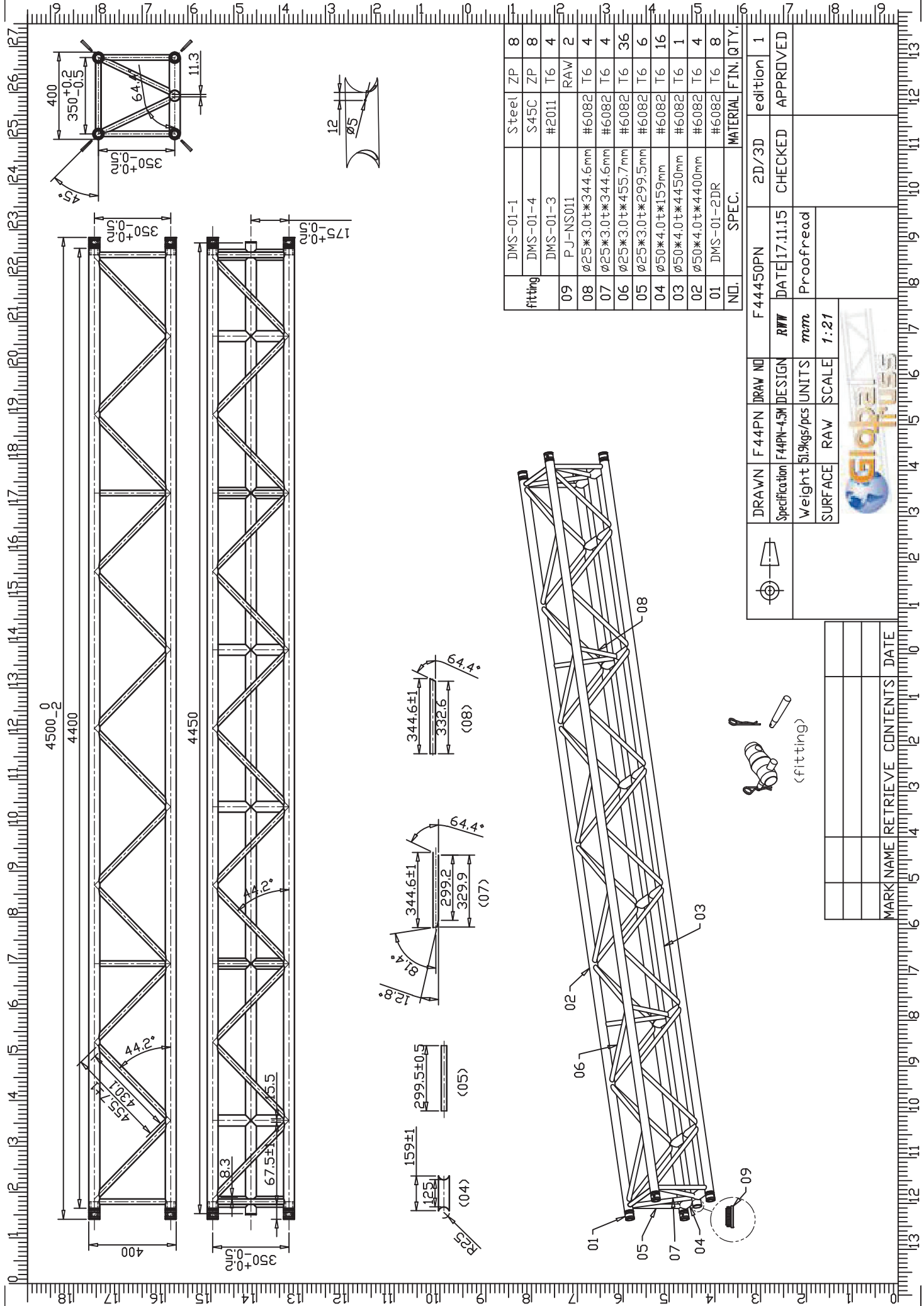

| | | | | |
|---------|------------------|--------------------|-----|----|
| fitting | DMS-01-1 | Steel | ZP | 8 |
| | DMS-01-4 | S45C | ZP | 8 |
| | DMS-01-3 | #2011 | T6 | 4 |
| 09 | PJ-NS011 | | RAW | 2 |
| 08 | ø25*3.0t*344.6mm | #6082 | T6 | 4 |
| 07 | ø25*3.0t*344.6mm | #6082 | T6 | 4 |
| 06 | ø25*3.0t*455.7mm | #6082 | T6 | 36 |
| 05 | ø25*3.0t*299.5mm | #6082 | T6 | 6 |
| 04 | ø50*4.0t*159mm | #6082 | T6 | 16 |
| 03 | ø50*4.0t*4450mm | #6082 | T6 | 1 |
| 02 | ø50*4.0t*4400mm | #6082 | T6 | 4 |
| 01 | DMS-01-2DR | #6082 | T6 | 8 |
| N.D. | SPEC. | MATERIAL FIN. QTY. | | |

| | | | | | | | | | |
|-----------|---------------|------------|---------|-----------|-------|----------|-----------|----------|--|
| | DRAWN | F 44PN | DRAW NO | F 44450PN | 2D/3D | edition | 1 | | |
| | Specification | F44PN-45M | DESIGN | RWW | DATE | 17.11.15 | CHECKED | APPROVED | |
| | Weight | 519kgs/pcs | UNITS | mm | | | Proofread | | |
| | SURFACE | RAW | SCALE | 1:21 | | | | | |
| | | | | | | | | | |
| MARK NAME | RETRIEVE | CONTENTS | DATE | | | | | | |

