

CROWD CONTROL SYSTEMS

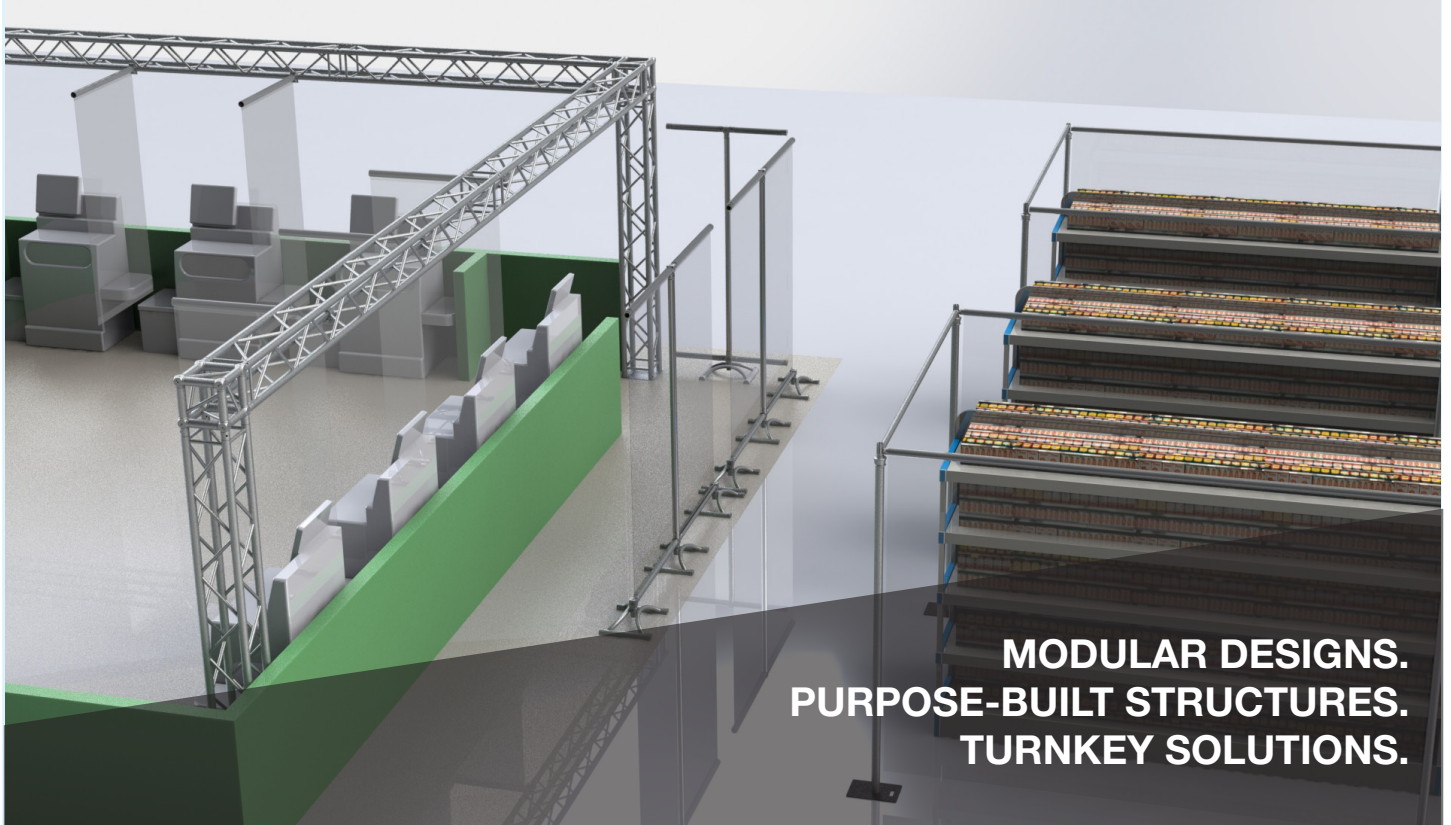

**MODULAR DESIGNS.
PURPOSE-BUILT STRUCTURES.
TURNKEY SOLUTIONS.**

In response to the increase in supermarket crowd flow safety concerns of the general public in association with the current crisis, our experienced team of designers have conceptualised a range of solutions and uses to the needs of temporary modular crowd control systems.

As the market leader for modular solutions across Australia, we pride ourselves in dealing with clients who are articulate about the quality and safety of our products and we are committed to helping our community and the general public form a safer environment and help you create the most efficient shopping experience for your customers.

Features and Benefits

- Completely modular design, easily expandable in different areas and controlling the flow of customers in queues
- Heavy-duty build allowing footpath management in store
- Vinyl walls for separators to assist in maintaining social distancing as well as continuing to servicing your customers
- Adaptable and customisable to suit any location and uses

We're here to help.

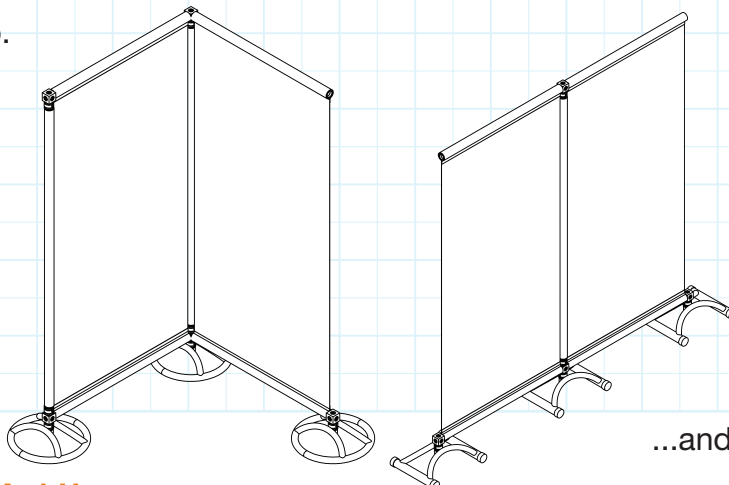

...and many more modular solutions

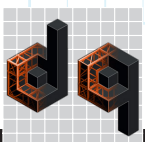

DQ.COM.AU

DESIGN QUINTESSENCE | **SYD** (02) 9649 2266 • **MELB** (03) 9645 2266 • **BRIS** 0419 777 877 • **PER** 0419 898 999 | **EMAIL** INFO@DQ.COM.AU