



Büro für Tragwerksplanung und Ingenieurbau
vom Felde + Keppler GmbH

Lütticher Straße 10 – 12
52064 Aachen
www.vom-felde.de

Telefon: 0241 709696
Telefax: 0241 709646
buero@vom-felde.de

Statische Berechnung
Structural Report

F34 Truss Extender

22400

Stand 26/09/2022

für das System der Firma
for the system by

Global Truss
Furong Industrial Area
Shajing Town

Baoan District Shenzhen China

Aufgestellt:
compiled by:

C. Fox

Aachen, 26.09.2022



Diese statische Berechnung umfasst die Seiten 1 - 31
This Structural Report includes pages

Diese statische Berechnung ist ausschließlich aufgestellt für die Firma Global Truss.
Eine Weitergabe an Dritte ist nur mit vorheriger Genehmigung des Aufstellers möglich.
This Structural Report is set up exclusively for the company Global Truss.
Forwarding to third parties only with the author's approval.



INHALTSVERZEICHNIS

Table of contents

1	VORBEMERKUNGEN / PRELIMINARY NOTES	2
1.1	Grundlagen / Basics	2
1.2	Verwendete Baustoffe / Materials	2
1.3	Allgemeine Beschreibung / General remarks.....	2
1.4	Geometrie und Belastung / Geonetry and loadings	4
3	QUERSCHNITTS - UND MATERIALEIGENSCHAFTEN / SECTION AND MATERIAL PROPERTIES.....	8
4	ZULÄSSIGE BELASTUNGEN EINZELBAUTEILE / ALLOWABLE LOADING SINGLE COMPONENTS	9
5	ZULÄSSIGE BELASTUNG EINFELDTRÄGER / ALLOWABLE LOADING SINGLE SPAN GIRDER	12
5.1	Statisches System / Structural System	12
5.2	Belastung / Loading.....	12
5.3	Berechnung / Calculation	12
5.4	Nachweise / Verifications	26
5.5	Umrechnung der Ergebnisse auf andere Spannweiten / Conversion of the results to other spans	28
6	ZUSAMMENFASSUNG DER ERGEBNISSE / SUMMARY OF THE RESULTS	30
6.1	Zulässige Belastung: / Allowable loadings:	30



1 VORBEMERKUNGEN

PRELIMINARY NOTES

1.1 Grundlagen

Basics

Die z.Zt. gültigen Vorschriften und Normen, insbesondere:

DIN EN 1991-1	Lastannahmen für Bauten (Eurocode 1) Actions on structures (Eurocode 1)
DIN EN 13814	Fliegende Bauten Fairground and amusement park machinery and structures
DIN EN 13782	Fliegende Bauten – Zelte Temporary Structures – Tents
DIN EN 1993-1	Bemessung und Konstruktion von Stahlbauten (Eurocode 3) Design of steel structures
DIN EN 1999-1	Bemessung und Konstruktion von Aluminiumtragwerken (Eurocode 9) Design of aluminium structures

1.2 Verwendete Baustoffe

Materials

Rohre / Tubes	Stahl Q235
Bolzen / Bolts	Güte mind. 8.8 (grade min. 8.8)

1.3 Allgemeine Beschreibung

General Remarks

Diese statische Berechnung beinhaltet die Berechnung und die Nachweise eines Verlängerungselements (Extender) für Traversensysteme des Typs F34 der Firma GLOBAL TRUSS.

In dieser Berechnung wird nur der Fall untersucht, dass das Verlängerungselement (Extender) an einem Ende eines Einfeldträgers angeordnet wird! Eine Anordnung an anderer Stelle oder in einem Mehrfeldträger wird im Rahmen dieser Berechnung nicht untersucht!

Das Verlängerungselement besteht aus 2 Endplatten, die über 4 Gurte – bestehend aus je 2 Gewinderohren und 2 Gewindehülsen – miteinander verbunden werden (siehe Kap. 2). Die Verbindung erfolgt mit Schrauben M12.

Die maximale Verlängerung beträgt 125 mm (siehe Kap. 1.4).

Der Achsabstand der Gurtrohre beträgt 24 cm in vertikaler Richtung und 24 cm in horizontaler Richtung.

Die zulässigen Belastungen sind in Tabellen aufgeführt (siehe Kap. 6).

Die Nachweise der Einzelbauteile erfolgen nach dem Sicherheitskonzept nach EN 1990 mit einem Teilsicherheitsbeiwert auf der Lastseite von $\gamma_F = 1,50$ für Nutzlasten.

Bei Anwendungsfällen, die auf Grundlage anderer Normen berechnet werden, können die Teilsicherheitsbeiwerte auf der Lastseite angepasst werden (z.B. fliegende Bauten nach EN 13814, $\gamma_F = 1,35$ für Nutzlasten).

Bei Anwendung des British Standard (BS) und des ANSI müssen die in den Tabellen aufgeführten zulässigen Belastungen mit dem Faktor 0,85 multipliziert werden.



This static report includes the calculation and verification of an extension element (extender) for truss systems of type F34 from GLOBAL TRUSS.

In this calculation only the case is examined that the extension element (extender) is arranged at one end of a single span girder! An arrangement at another place or in a multi-span girder is not examined within the scope of this calculation!

The extender element consists of 2 end plates, which are connected to each other via 4 chords - each consisting of 2 threaded tubes and 2 threaded sleeves (see chapter 2). The connection is executed with M12 screws.

The maximum extension is 125 mm (see chapter 1.4).

The center distance of the belt tubes is 24 cm in vertical direction and 24 cm in horizontal direction.

The permissible loads are listed in tables (see chapter 6).

The verifications of the individual components are carried out according to the safety concept of EN 1990 with a partial safety factor on the load side of $\gamma_F = 1.50$ for live loads.

For applications calculated on the basis of other standards, the partial safety factors on the load side can be adapted (e.g. flying structures according to EN 13814, $\gamma_F = 1.35$ for live loads).

When using the British Standard (BS) and ANSI, the allowable loads listed in the tables must be multiplied by a factor of 0.85.



1.4 Geometrie und Belastung

Geometry and Loadings

Als Belastung werden folgende Lastarten untersucht /
The following loadcases are taken into account

Gleichlast vertikal
uniformly distributed load (UDL)

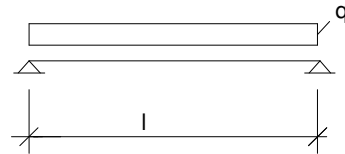

Einzellast in Feldmitte
Single-load in 1/2 point

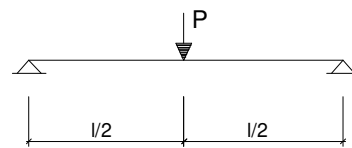

Einzellasten in den Drittelpunkten
Single-load in 1/3 point

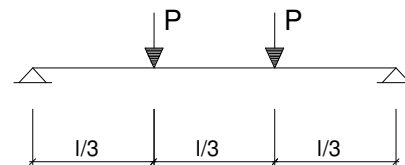

Einzellasten in den Viertelpunkten
Single-load in 1/4 point

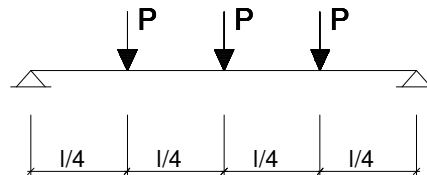

Einzellasten in den Fünftelsspunkten
Single-load in 1/5 point

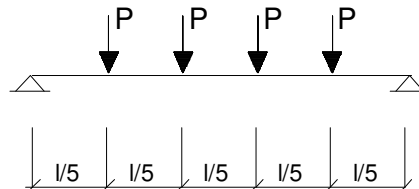

Das Eigengewicht der Traverse wird wie folgt angesetzt:
The selfweight of the truss is applied as follows:

F34 = 6 kg/m



Für die Anwendung der hier ermittelten Belastungswerte gelten folgende Regeln:
For the application of the calculated allowable loadings the following rules have to be regarded:

Maximale Verlängerung:
Maximum extension:

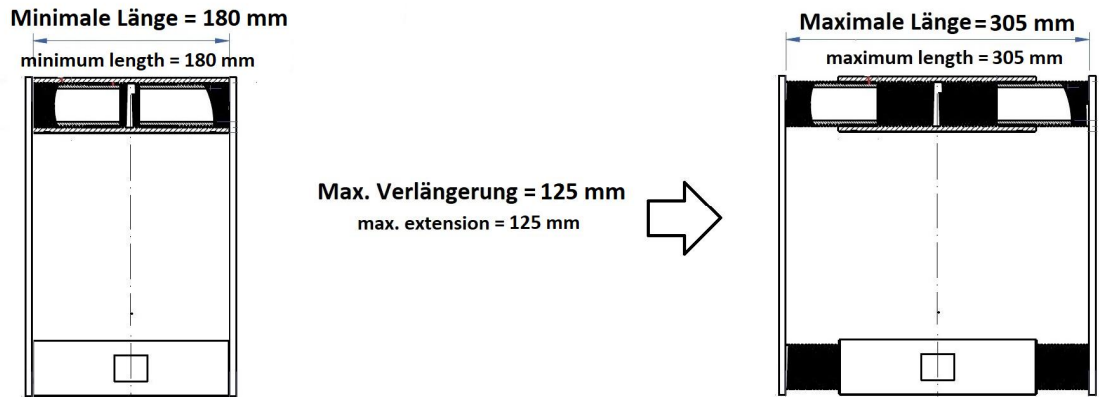

Der Extender wird immer am Ende des Einfeldträgers angeordnet (siehe folgende Seite).
The extender is always placed at the end of the single span beam (see following page).

Alle Lasten sind gleichmäßig auf beide Gurte zu verteilen.
All loads have to be distributed equally to both chords.

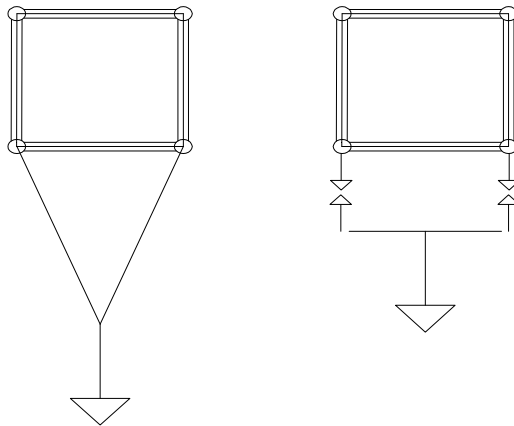

Für die Auflagerung bzw. Aufhängung des Systems bestehen folgende Möglichkeiten:
For the support or suspension there are the following possibilities:

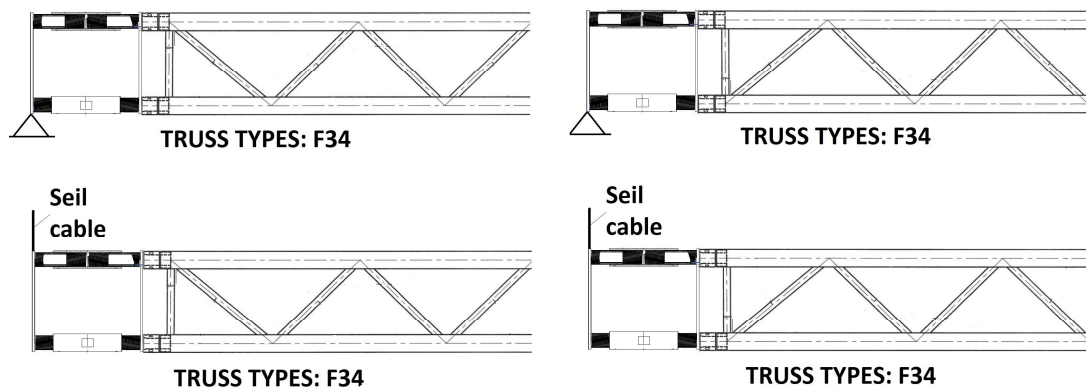



2 SYSTEM

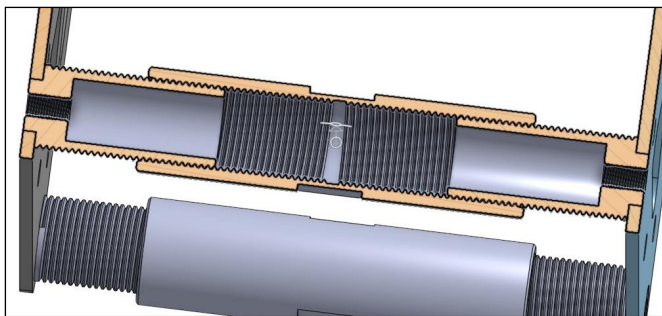
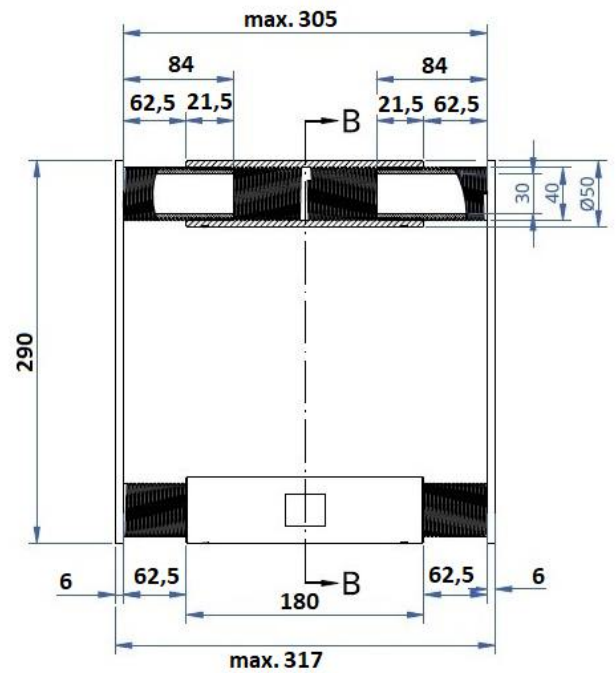
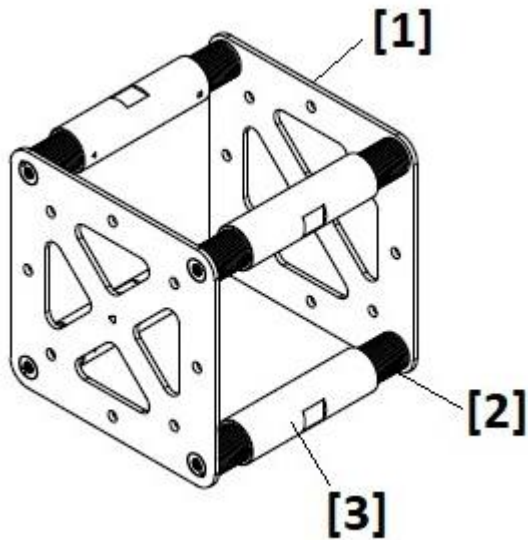

Halbkonus $\varnothing 40$ mm
mit Schraube M12 (8.8 oder 10.9)
Half conical $\varnothing 40$ mm with screw (8.8 or 10.9)



Einschraubtiefe mind. 15 mm
Screw-in depth min. 15 mm

[1] Platte
plate

Stahl Q235
Steel Q235

$t = 6$ mm
 $t = 6$ mm

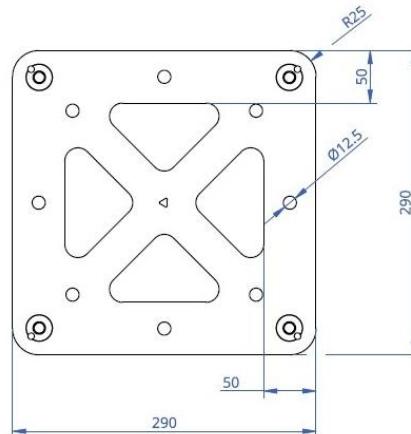
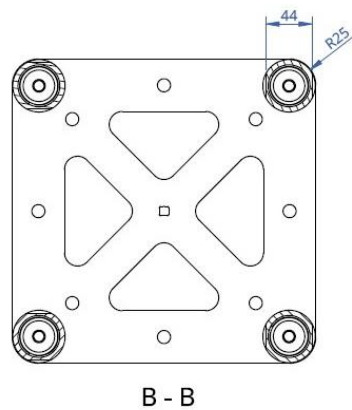



[2]

Gewinderohr
Threaded pipe

Stahl Q235
Steel Q235

Kernquerschnitt
core section

ø37x3,5 mm
ø37x3.5 mm

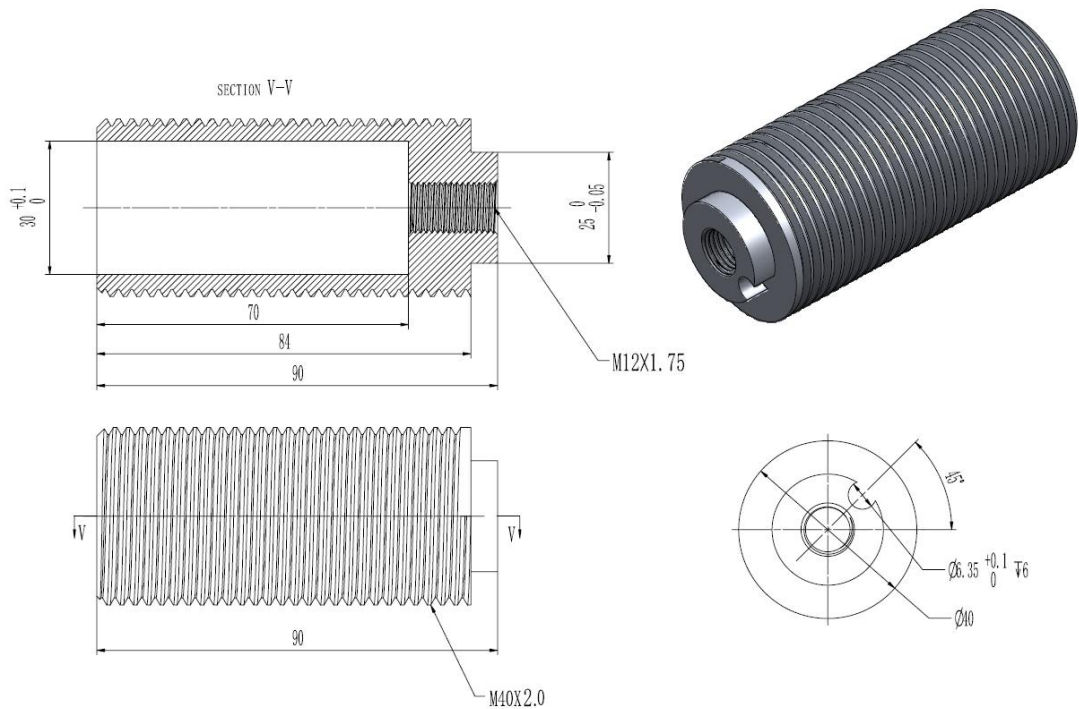

[3]

Gewindehülse
Threaded sleeve

Stahl Q235
Steel Q235

Kernquerschnitt
core section

ø50x5,0 mm
ø50x5.0 mm

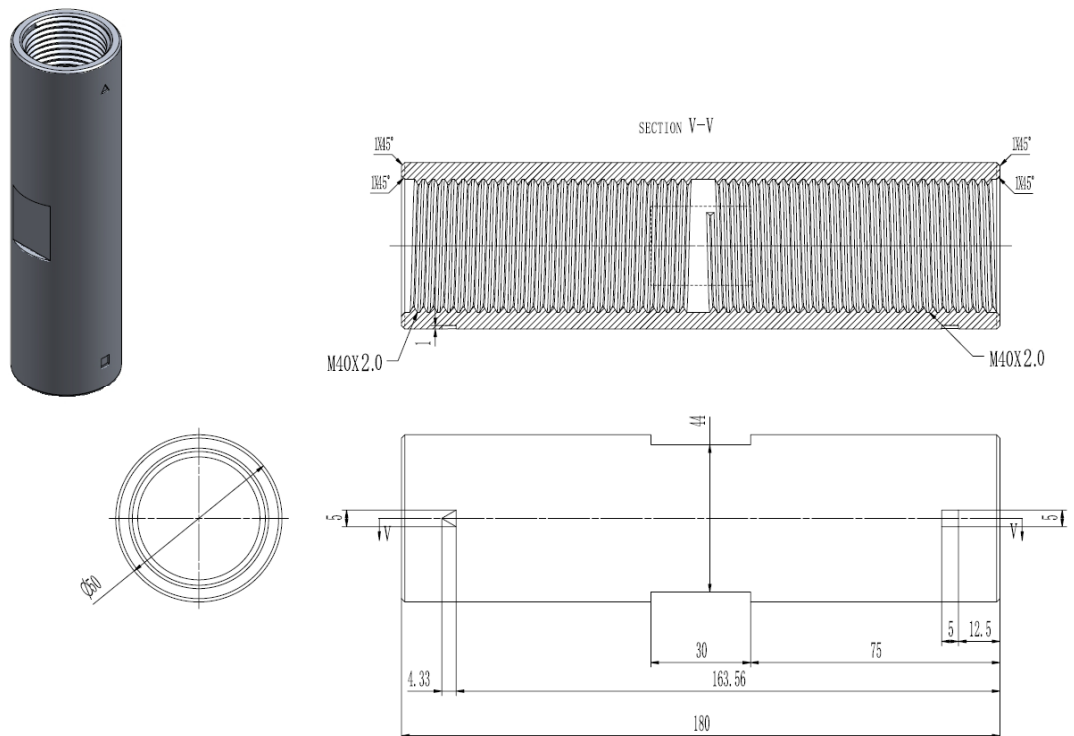



3 QUERSCHNITTS - UND MATERIALEIGENSCHAFTEN

SECTION- AND MATERIAL PROPERTIES

[1]	Platte plate	Material Material	Stahl Q235 Steel Q235
	Streckgrenze Yield strength	$f_{yk} = 235 \text{ N/mm}^2$	
	Zugfestigkeit Tensile strength	$f_{uk} = 235 \text{ N/mm}^2$	
	Dicke Thickness	$t = 6 \text{ mm}$	
	Mitwirkende Breite Effective width	Schnitt A-A Section A-A	$b_{\text{eff}} = 90 - 13 = 77 \text{ mm}$
		Schnitt B-B Section B-B	$b_{\text{eff}} = 50 \text{ mm}$

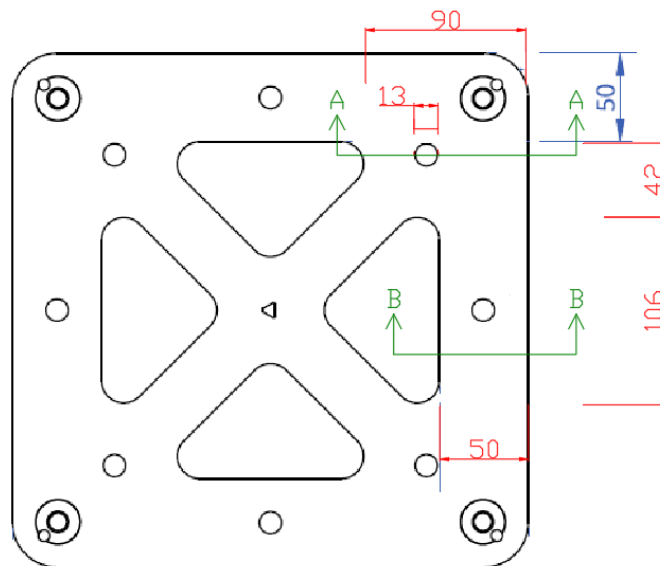

[2]	Gewinderohr Threaded pipe	Material Material	Stahl Q235 Steel Q235
	Streckgrenze Yield strength	$f_{yk} = 235 \text{ N/mm}^2$	
	Zugfestigkeit Tensile strength	$f_{uk} = 235 \text{ N/mm}^2$	
	Kernquerschnitt core section	$\varnothing 37 \times 3,5 \text{ mm}$ $\varnothing 37 \times 3,5 \text{ mm}$	



[3]	Gewindehülse Threaded sleeve	Material Material	Stahl Q235 Steel Q235
	Streckgrenze Yield strength	$f_{yk} = 235 \text{ N/mm}^2$	
	Zugfestigkeit Tensile strength	$f_{uk} = 235 \text{ N/mm}^2$	
	Kernquerschnitt core section	Regelquerschnitt Standard cross section	$\varnothing 50 \times 5,0 \text{ mm}$ $\varnothing 50 \times 5.0 \text{ mm}$

Querschnitt im Bereich der Abflachung:
Cross section in the area of the flattening:

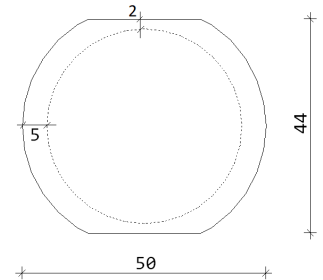

[4]	Schraube Screw	M12
	Festigkeitsklasse Strength class	8.8 oder 10.9 8.8 or 10.9
	Einschraubtiefe Screw-in depth	mind. 15 mm min. 15 mm



4 ZULÄSSIGE BELASTUNGEN EINZELBAUTEILE

ALLOWABLE LOADING SINGLE COMPONENTS

[1]	Platte plate	Material Material	Stahl Q235 Steel Q235
	Max. Spannung Max. stress	$\sigma_{Rd} = 235 \text{ N/mm}^2$	
[2]	Gewinderohr Threaded pipe	Material Material	Stahl Q235 Steel Q235
	Max. Spannung Max. stress	$\sigma_{Rd} = 235 \text{ N/mm}^2$	
	Einschraubung Srew-in	Übertragbares Biegemoment Transferable bending moment	
		Minimale Einschraubtiefe $s = 21,5 \text{ mm}$ Minimum screw-in length	
		Durchmesser Diameter	$d = 37 \text{ mm}$
		Widerstandsmoment Section modulus	$W' = \pi \cdot (3,7 / 2)^2 = 10,75 \text{ cm}^2$
		Max. Schubspannung Max. shear stress	$\tau_{Rd} = 23,5 / 3^{0,5} = 13,56 \text{ kN/cm}^2$
		Spannungsverteilung Stress distribution	linear $\Rightarrow \tau = 2 \cdot M / (W' \cdot s)$
		Max. Biegemoment Max. bending moment	$M_{Rd} = 13,56 / 2 \cdot 10,75 \cdot 2,15 = 156 \text{ kNcm}$
[3]	Gewindehülse Threaded sleeve	Material Material	Stahl Q235 Steel Q235
	Max. Spannung Max. stress	$\sigma_{Rd} = 235 \text{ N/mm}^2$	
[4]	Schraube Screw	M12	
	Einschraubtiefe Screw-in depth	mind. 15 mm min. 15 mm	
	Max. Zugkraft Max. tensile force	nach DIN EN 1993-1-8/NA acc. DIN EN 1993-1-8/NA	
		$\xi = (600 / f_{u,k}) \cdot (0,3 + 0,4 \cdot f_{u,b,k} / 500)$	
		Q235	$\Rightarrow f_{u,k} = 360 \text{ N/mm}^2$
		a)	$8.8 \Rightarrow f_{u,b,k} = 800 \text{ N/mm}^2$ $\xi (600 / 360) \cdot (0,3 + 0,4 \cdot 800 / 500) = 1,57$ $F_{tRd} = 48,6 \cdot 15 / (1,57 \cdot 12) = \mathbf{38,8 \text{ kN}}$
		b)	$10.9 \Rightarrow f_{u,b,k} = 1000 \text{ N/mm}^2$ $\xi (600 / 360) \cdot (0,3 + 0,4 \cdot 1000 / 500) = 1,83$ $F_{tRd} = 60,7 \cdot 15 / (1,83 \cdot 12) = 41,5 \text{ kN}$



[5]	Guttröhre Traverse Truss chord	in Wärmeeinflusszone in heat-affected zone
	Traversentyp F34 Truss type F34	ø50 x 2 mm
		Bemessungswert der Normalkraft $N_{Rd} = 35,71$ kNcm Design value of the normal force
		Bemessungswert des Biegemomentes $M_{Rd} = 42,85$ kNcm Design value of the bending moment



5 ZULÄSSIGE BELASTUNG EINFELDTRÄGER

ALLOWABLE LOADING SINGLE SPAN GIRDER

5.1 Statisches System

Structural System

Die Berechnung erfolgt an einem System mit maximaler Länge des Extenders von 402 mm und einem 4 m langem Traversenstück.

Weitere Spannweiten werden über Vergleichrechnung erfasst. Es wird eine Leiterbene mit 2 Ausrichtungen der Diagonalen betrachtet.

The calculation is done with a system with maximum length of the extender (402 mm) and a 4 m long truss piece. Further spans are recorded via comparative calculations. A ladder plane with 2 orientations of the diagonals is taken into account.

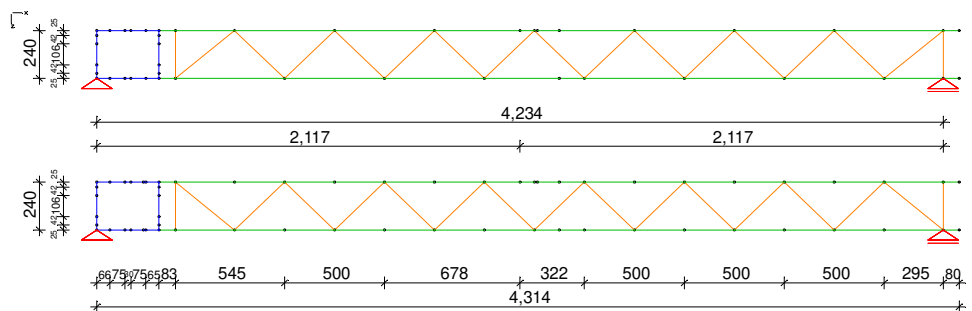

5.2 Belastung

Loading

1) Eigengewicht 1) Selfweight	Traversentyp Truss type	Gesamtlast Total load	pro Leiter per ladder
	F34	[kN/m] $g_T = 0,06$	[kN/m] $g = 0,030$
2) Einzellast mittig 2) Center point load	Traversentyp Truss type	Gesamtlast Total load	pro Leiter per ladder
	F34	[kN] $P_T = 7,70$	[kN] $P = 3,85$
3) Streckenlast 3) Uniformly distributed load	Traversentyp Truss type	Gesamtlast Total load	pro Leiter per ladder
	F34	[kN/m] $p_T = 1,82$	[kN/m] $p = 0,91$

5.3 Berechnung

Calculation

siehe folgende Seiten
see following pages



22400 – Extender F34

26.09.2022

M 1 :

System characteristics

- 102 Nodes
- 136 Beams
- 4 Supports
- 0 Link elements
- 7 Material and section properties
- 3 Load cases
- 1 Load case combinations
- 5 Result locations in beam elements

Section properties

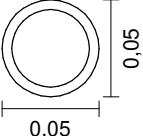
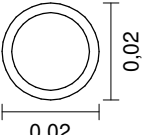
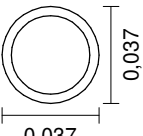
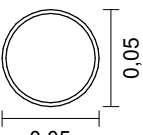
1	Parameter 	RO 50/5; Sleeve Centroid [m] $y_s = 0,000$ $z_s = 0,000$ Area [m ²] $A = 7,0233e-04$ Moments of inertia [m ⁴] $I_y = 1,7882e-07$ $I_1 = 1,7882e-07$ $I_z = 1,7882e-07$ $I_2 = 1,7882e-07$ Main axis angle [Grad] $\Phi = 0,000$ $I_{yz} = 0,0000e+00$
2	Parameter 	RO 20/2; Dia F34 Centroid [m] $y_s = 0,000$ $z_s = 0,000$ Area [m ²] $A = 1,1237e-04$ Moments of inertia [m ⁴] $I_y = 4,5777e-09$ $I_1 = 4,5777e-09$ $I_z = 4,5777e-09$ $I_2 = 4,5777e-09$ Main axis angle [Grad] $\Phi = 0,000$ $I_{yz} = 0,0000e+00$
3	Rectangle	Platte 1 Width, height [m] $dy = 0,050$ $dz = 0,006$
4	Parameter 	RO 37/4; Screw Centroid [m] $y_s = 0,000$ $z_s = 0,000$ Area [m ²] $A = 3,6599e-04$ Moments of inertia [m ⁴] $I_y = 5,1569e-08$ $I_1 = 5,1569e-08$ $I_z = 5,1569e-08$ $I_2 = 5,1569e-08$ Main axis angle [Grad] $\Phi = 0,000$ $I_{yz} = 0,0000e+00$
5	Parameter 	RO 50/2; Gurt F34 Centroid [m] $y_s = 0,000$ $z_s = 0,000$ Area [m ²] $A = 2,9966e-04$ Moments of inertia [m ⁴] $I_y = 8,5898e-08$ $I_1 = 8,5898e-08$ $I_z = 8,5898e-08$ $I_2 = 8,5898e-08$ Main axis angle [Grad] $\Phi = 0,000$ $I_{yz} = 0,0000e+00$
6	Rectangle	Platte 2 Width, height [m] $dy = 0,077$ $dz = 0,006$



22400 – Extender F34

26.09.2022

M 1 :

Section properties

7		Polygon	Sleeve mid		
			Centroid [m]	ys = 0,000	zs = 0,000
			Area [m²]	A = 6,1006e-04	
			Moments of inertia [m4]	ly = 1,2921e-07	l1 = 1,2921e-07
				lz = 1,7625e-07	l2 = 1,7625e-07
			Main axis angle [Grad]	Phi = 0,000	lyz = 0,0000e+00
			Averaging of the lateral force shear stress over section width		
			Specified cross-section class according to 1993-1-1: 3		

Material

	No.	Type	E-Modul [MN/m²]	alpha.t [1/K]	gamma [kN/m³]	Miscellaneous
1	1	S235-EN	210000	1,2e-05	78,500	
2	2	Frei	70000	2,3e-05	27,000	fc = 235 [MN/m²] ft = 235
3	3	S235-EN	210000	1,2e-05	78,500	
4	4	S235-EN	210000	1,2e-05	78,500	
5	5	Frei	70000	2,3e-05	27,000	fc = 235 [MN/m²] ft = 235
6	6	S235-EN	210000	1,2e-05	78,500	
7	7	S235-EN	210000	1,2e-05	78,500	

Supports

	Node No.	'F'=fix '='=free	x direction		'F'=fix '='=free	z direction		Rotation	
			Spring [MN/m]	Angle [grad]		Spring [MN/m]	Angle [grad]	'F'=fix '='=free	Spring [MNm]
1	35	-	0,00e+00	-0,00	F	0,00e+00	0,00	-	0,00e+00
2	61	F	0,00e+00	-0,00	F	0,00e+00	0,00	-	0,00e+00
3	78	-	0,00e+00	-0,00	F	0,00e+00	0,00	-	0,00e+00
4	109	F	0,00e+00	-0,00	F	0,00e+00	0,00	-	0,00e+00

The angle describes the rotation of the support compared to the specified direction.



22400 – Extender F34

26.09.2022

M 1 :

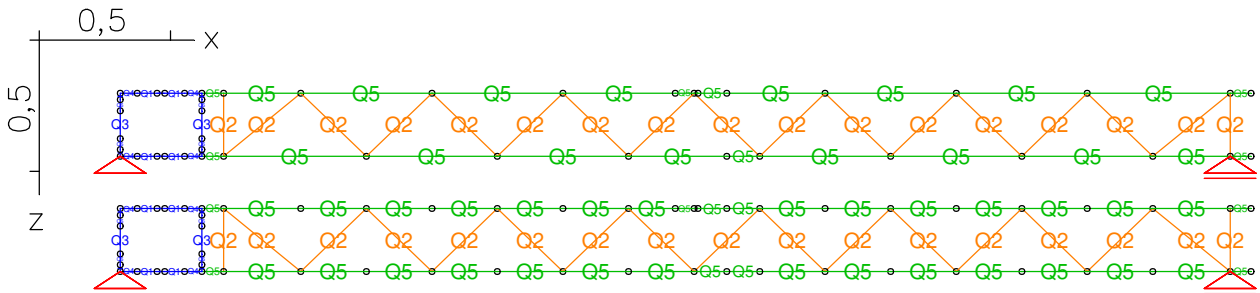

Section numbers

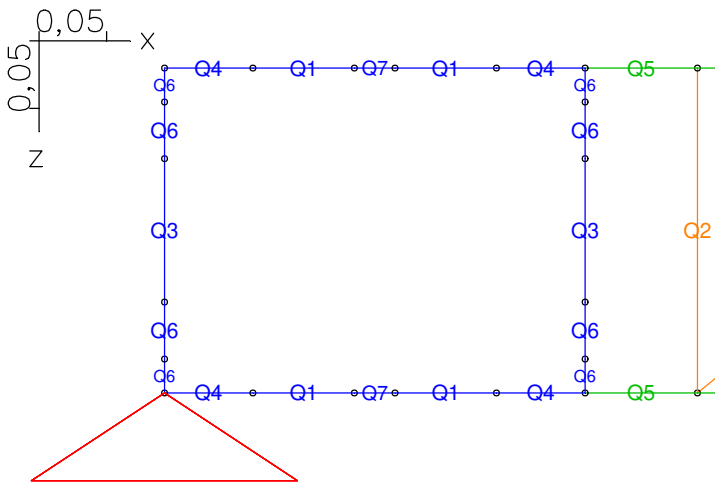

Section numbers

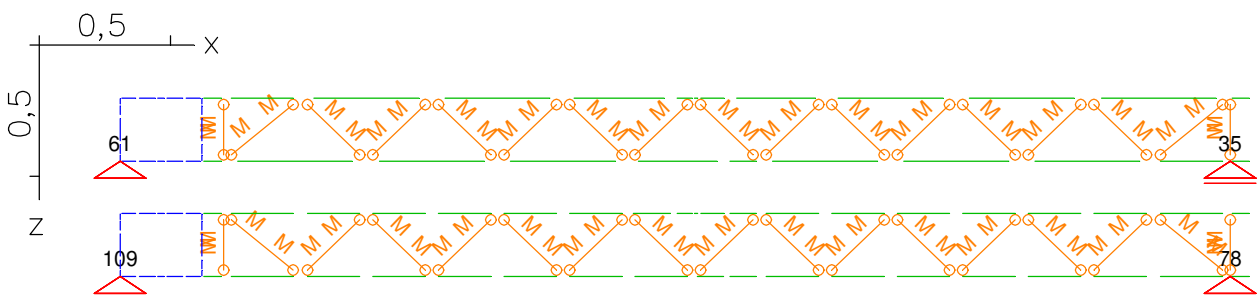

Support numbers; Shrink mode; Joint info



22400 – Extender F34

26.09.2022

M 1 :

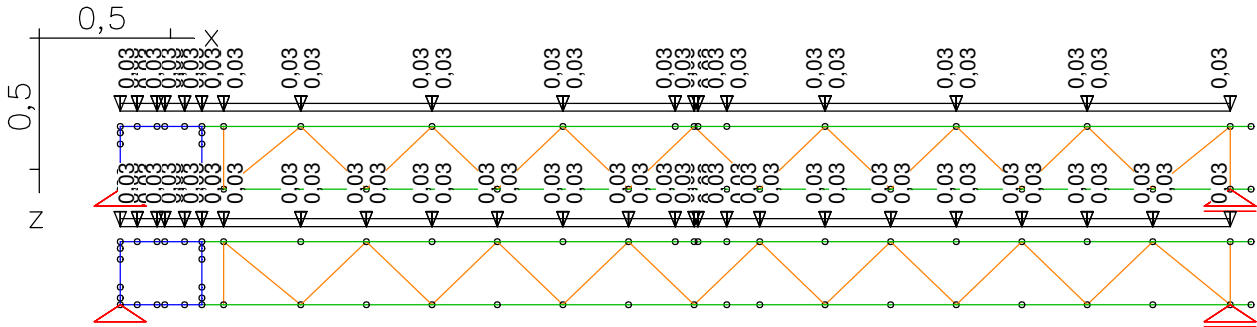

LC 1: Load, g

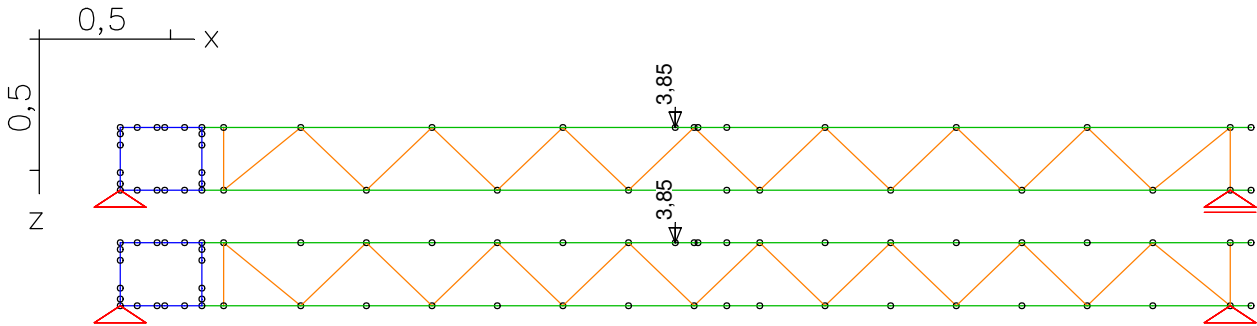

LC 2: Load, P

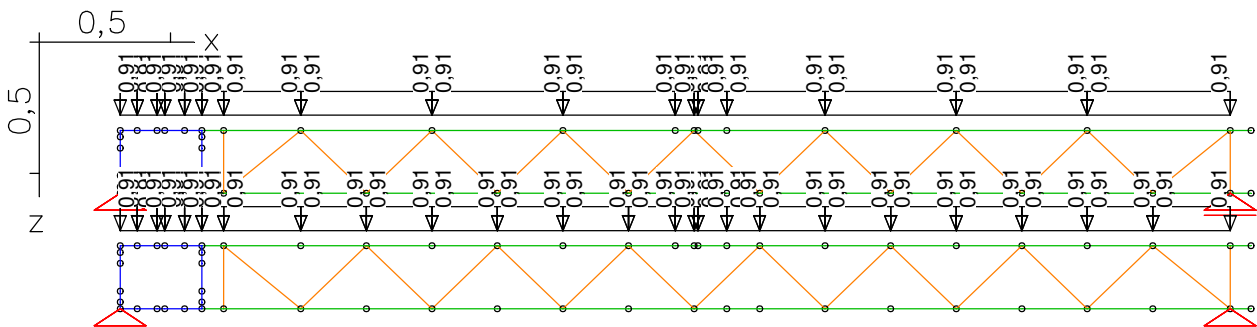

LC 3: Load, p

Load case combination 100, ULS

Permanent action		Factor
1	g	1,350
Exclusive selection		Factor
2	P	1,500
3	p	1,500



22400 – Extender F34

26.09.2022

M 1 :

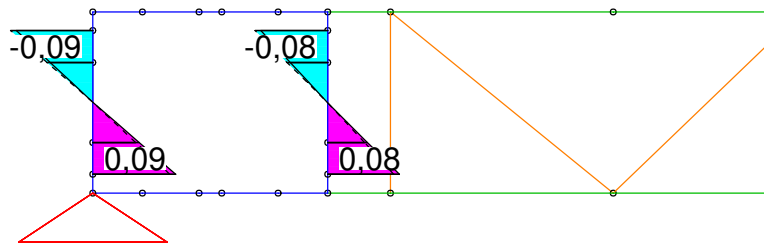
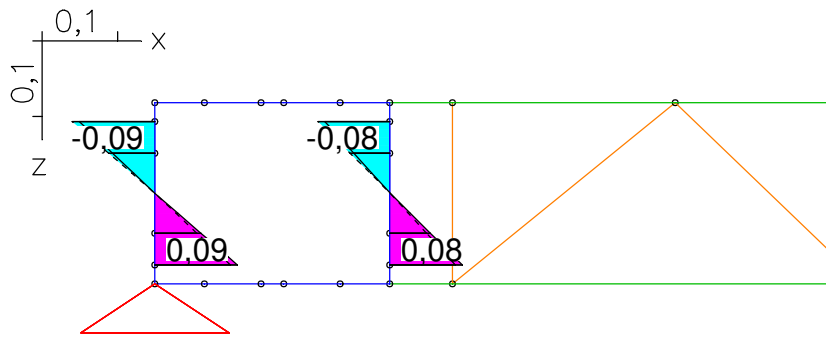

Internal forces M_y min, max; LFK K100, ULS

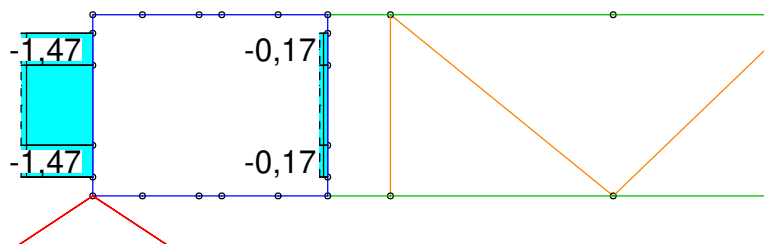
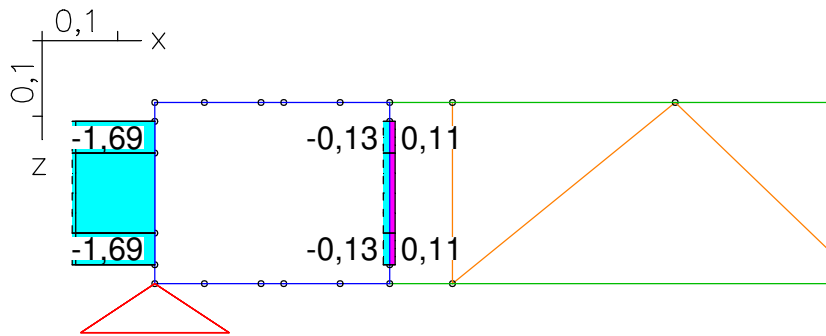

Internal forces N_x min, max; LFK K100, ULS



22400 – Extender F34

26.09.2022

M 1 :

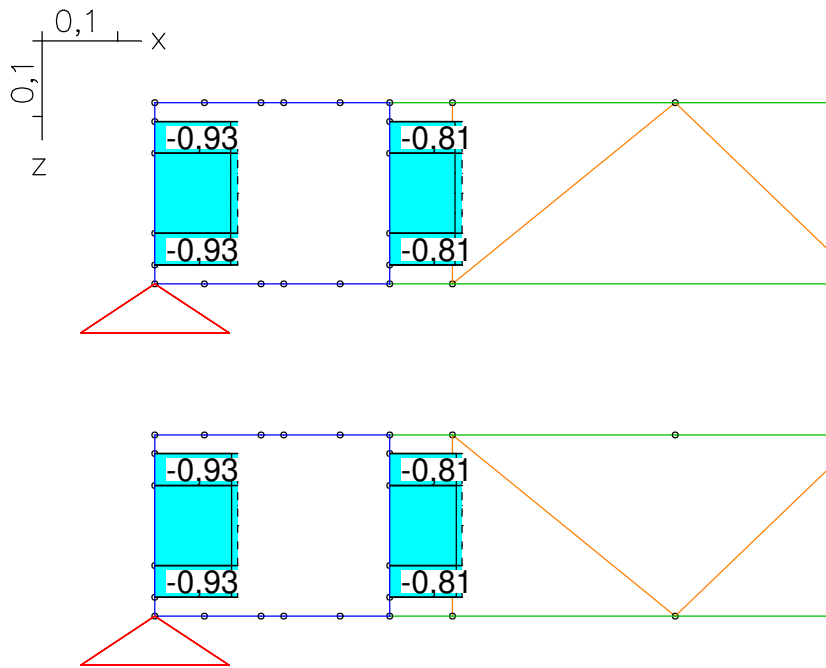

Internal forces Qz min, max; LFK K100, ULS

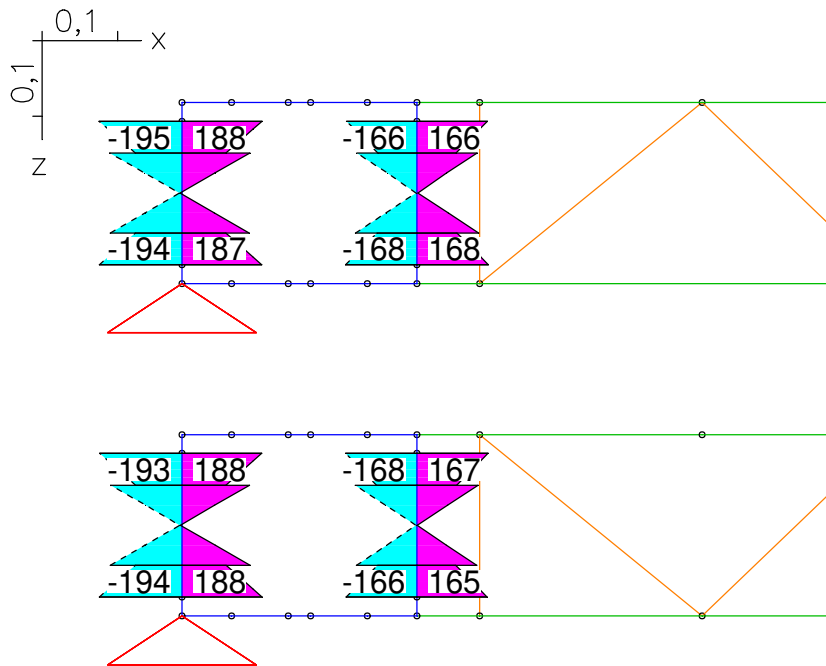

Sigma.x min, max; LFK K100, ULS



22400 – Extender F34

26.09.2022

M 1 :

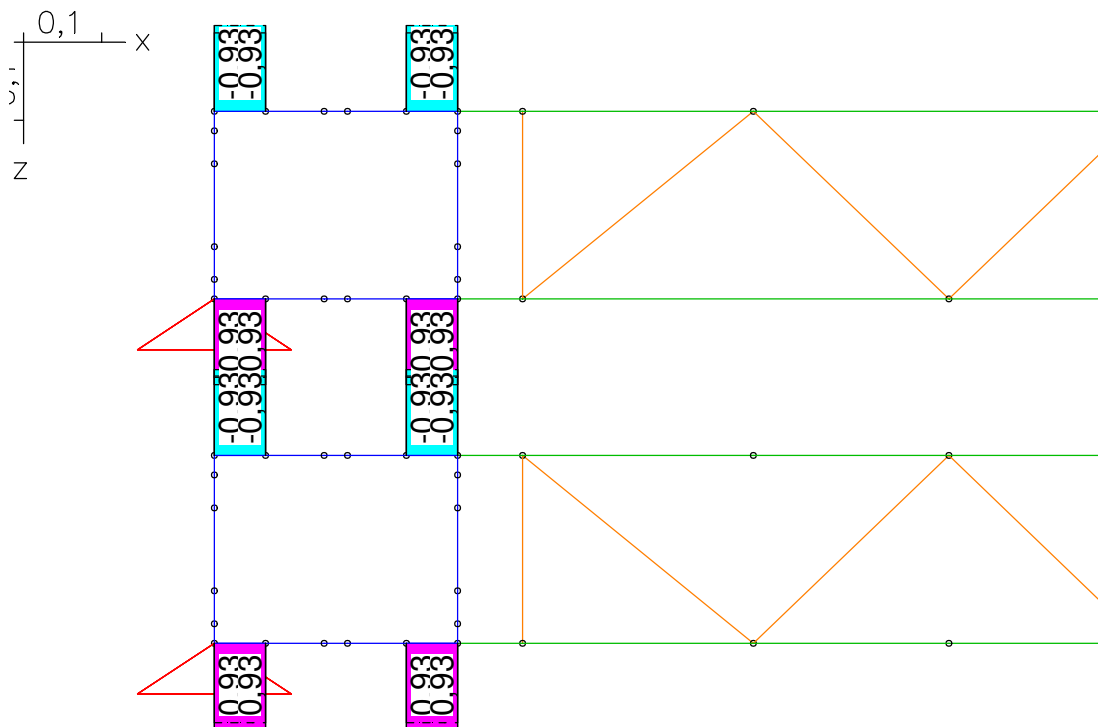
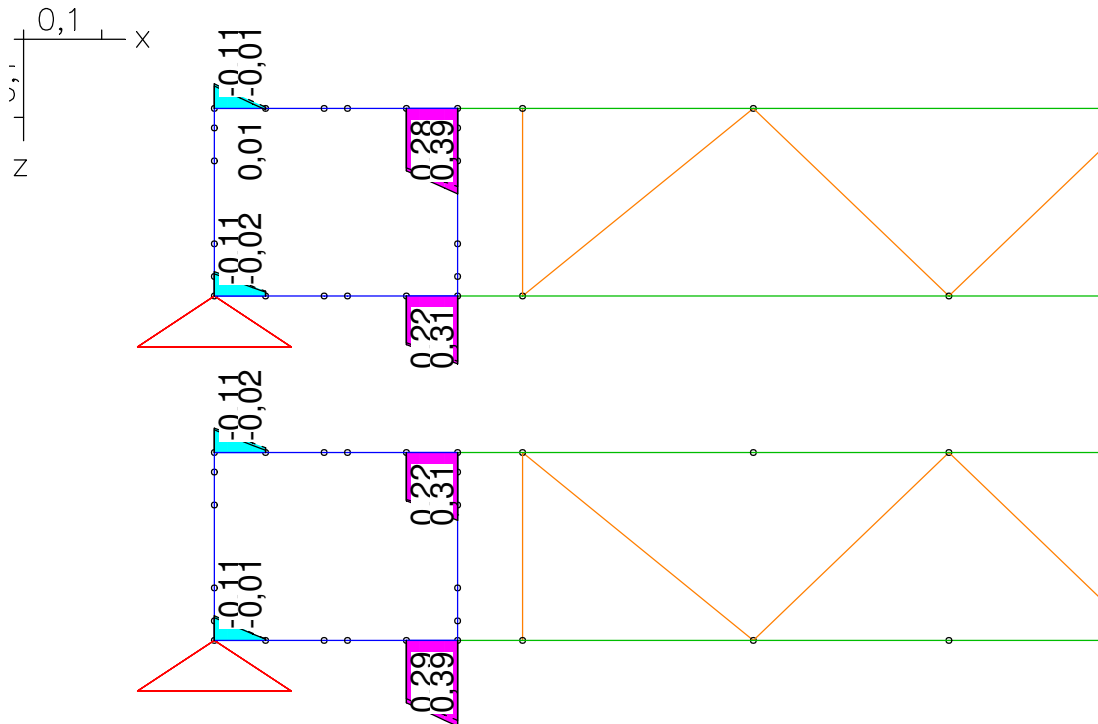

Internal forces Nx min, max; LFK K100, ULS



22400 – Extender F34

26.09.2022

M 1 :

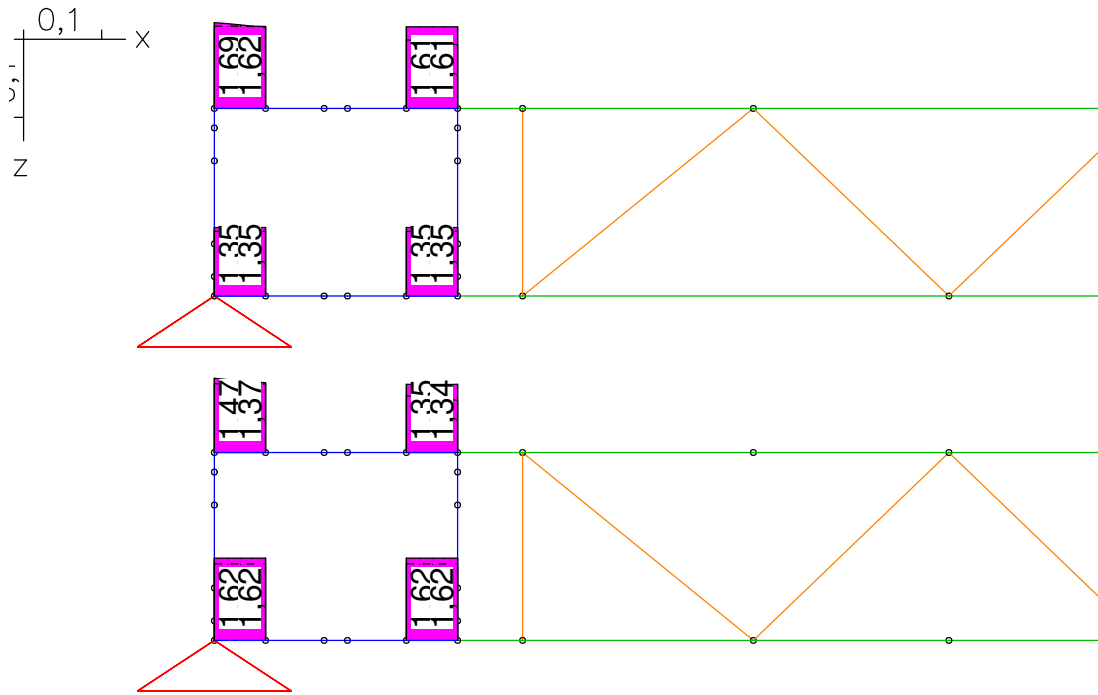

Internal forces Qz min, max; LFK K100, ULS

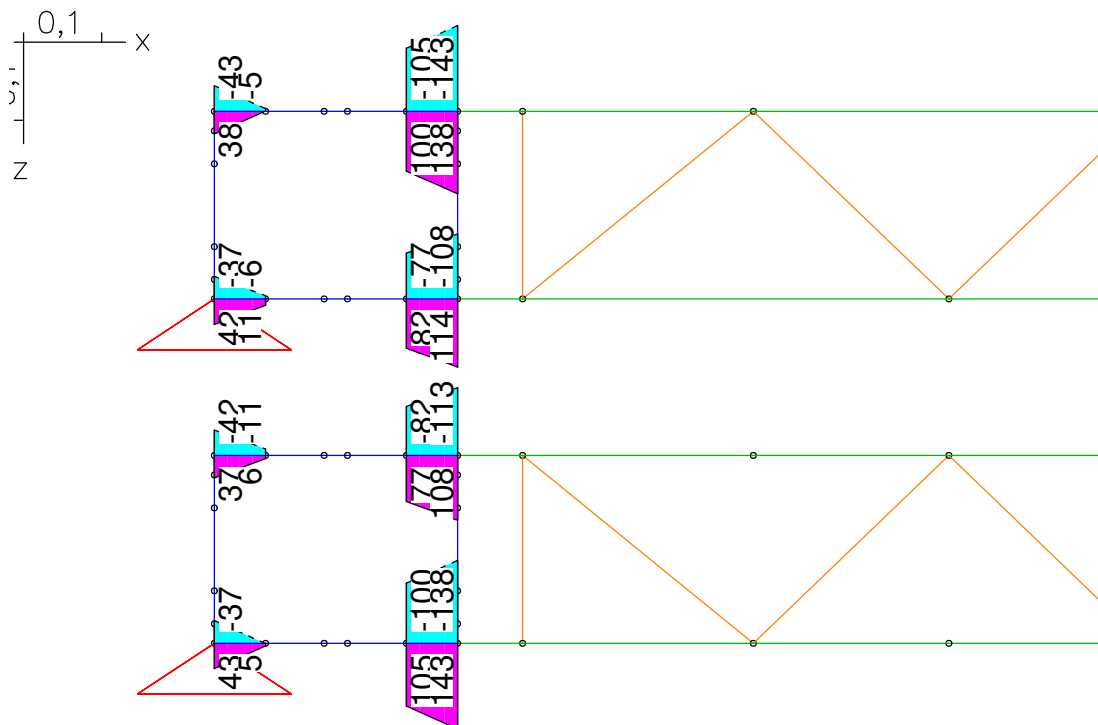

Sigma.x min, max; LFK K100, ULS



22400 – Extender F34

26.09.2022

M 1 :

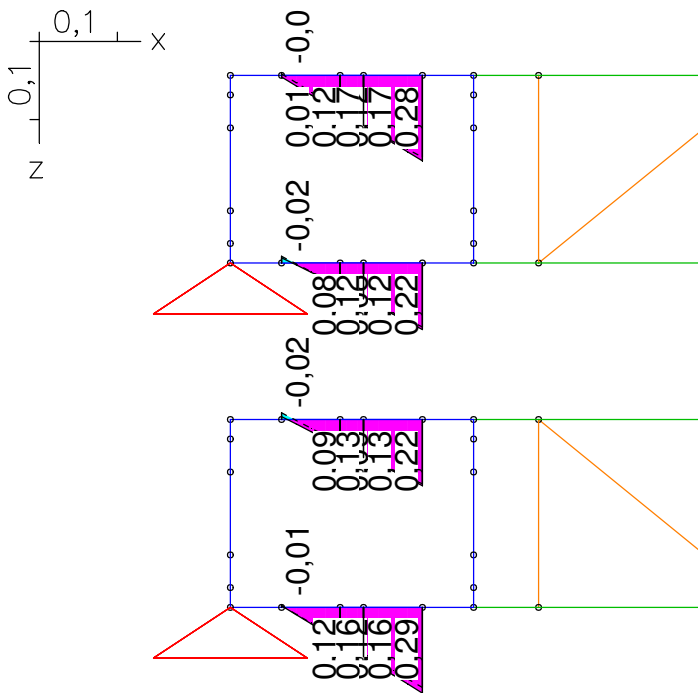

Internal forces My min, max; LFK K100, ULS

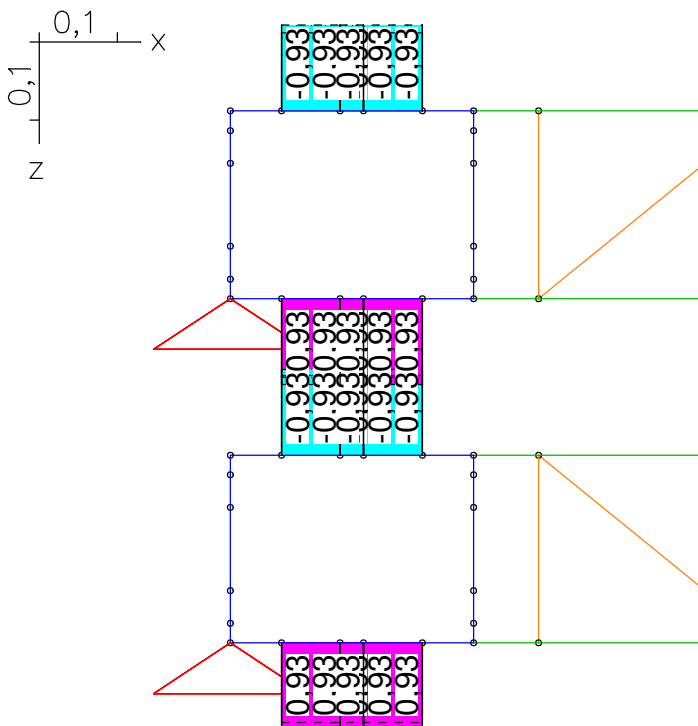

Internal forces Nx min, max; LFK K100, ULS



22400 – Extender F34

26.09.2022

M 1 :

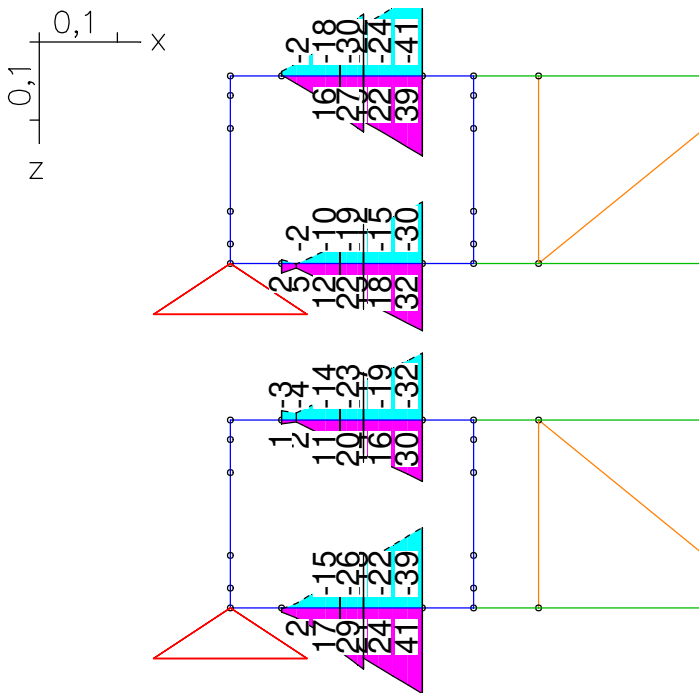
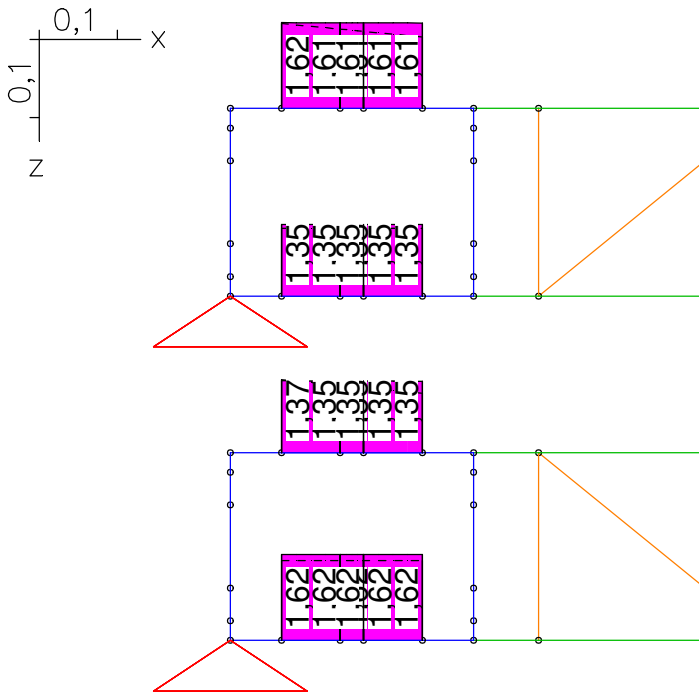



22400 – Extender F34

26.09.2022

M 1 :

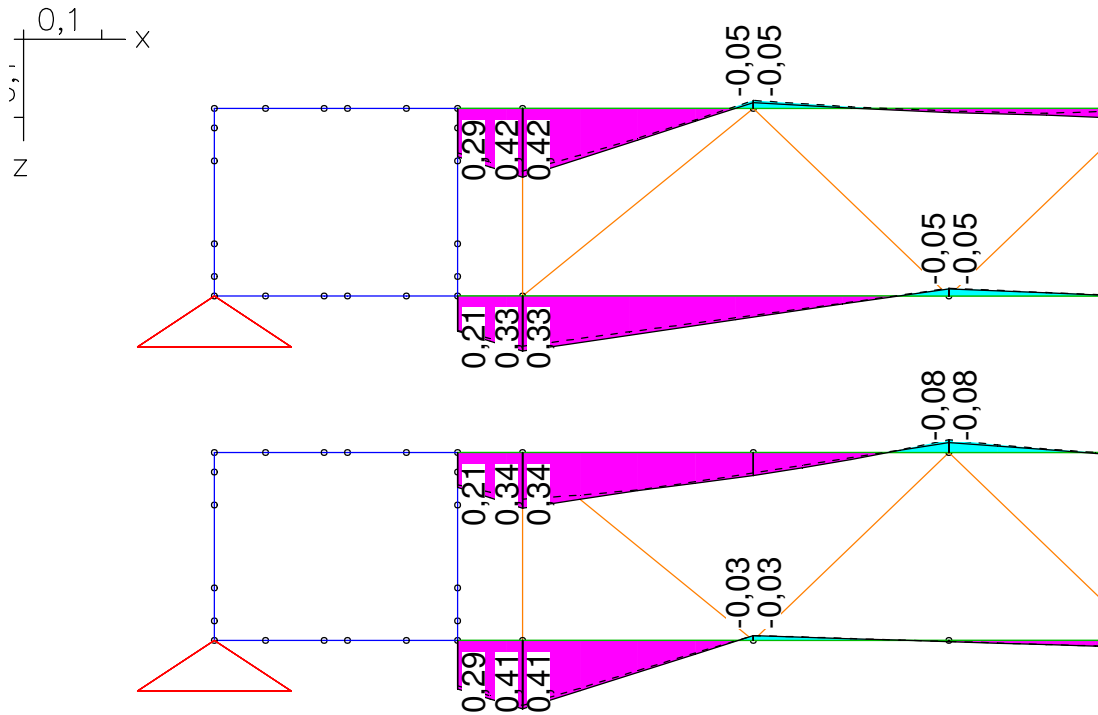

Internal forces My min, max; LFK K100, ULS

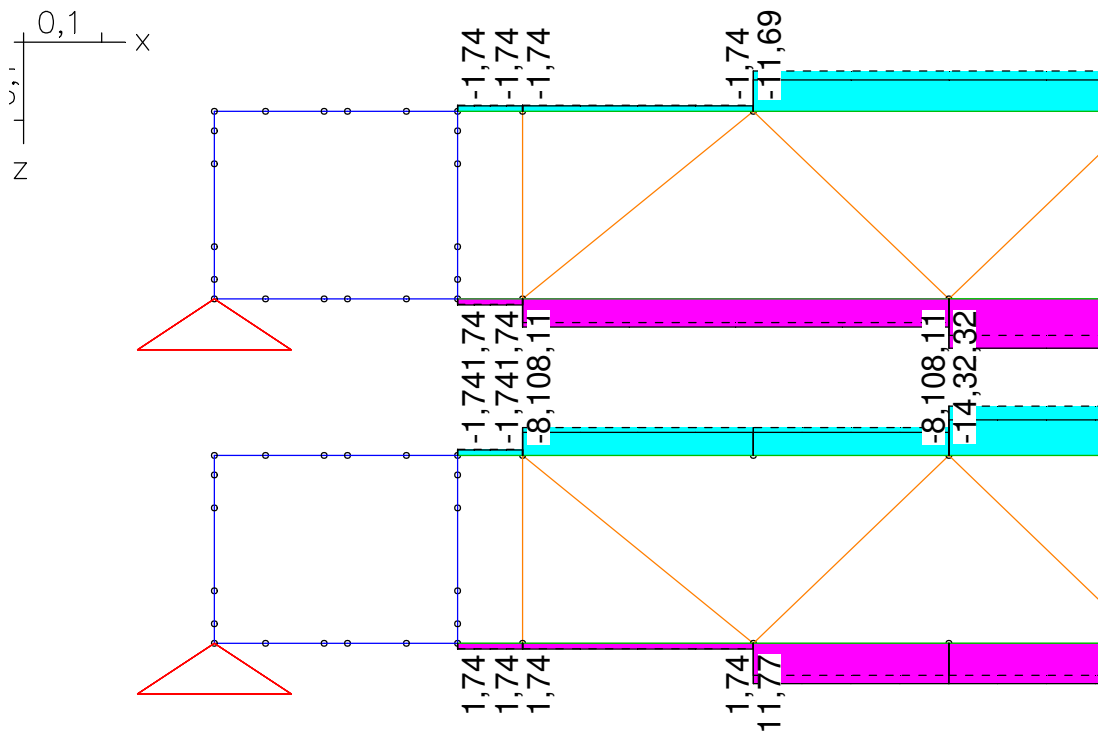

Internal forces Nx min, max; LFK K100, ULS



22400 – Extender F34

26.09.2022

M 1 :

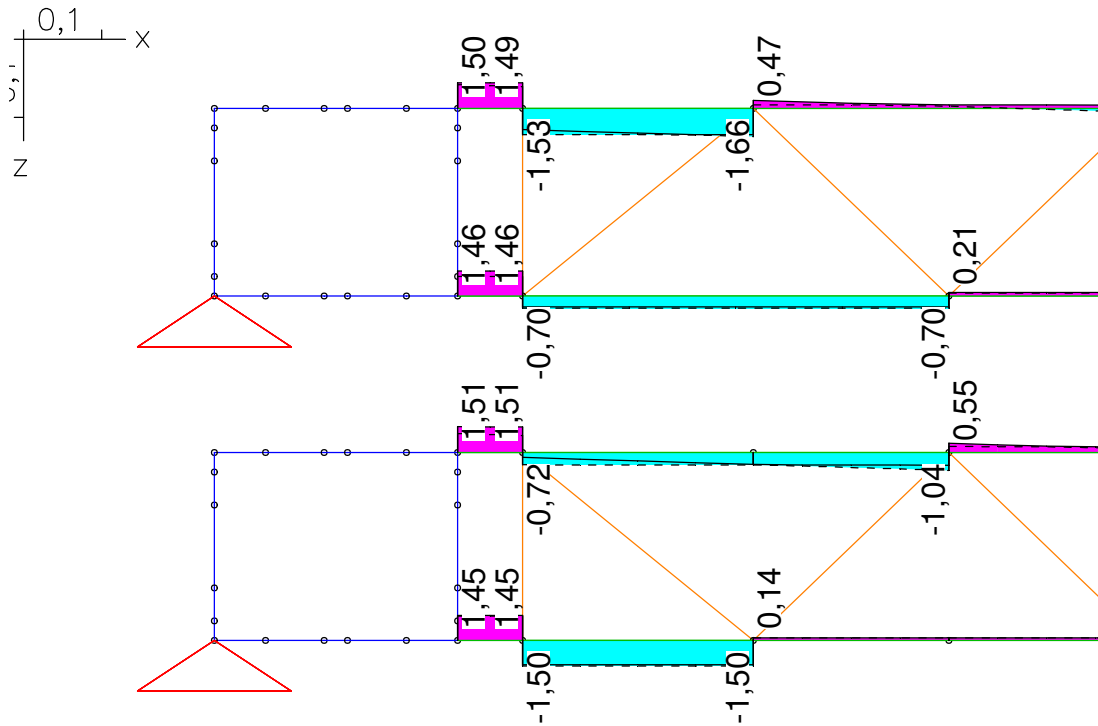

Internal forces Qz min, max; LFK K100, ULS

Support reactions from all load cases

Node	Load case	Rx [kN]	Rz [kN]	My [kNm]
35	1	0,00	0,06	0,00
	2	0,00	1,93	0,00
	3	0,00	1,93	0,00
61	1	0,00	0,06	0,00
	2	0,00	1,92	0,00
	3	0,00	1,93	0,00
78	1	0,00	0,06	0,00
	2	0,00	1,93	0,00
	3	0,00	1,93	0,00
109	1	0,00	0,06	0,00
	2	0,00	1,92	0,00
	3	0,00	1,93	0,00



22400 – Extender F34

26.09.2022

M 1 :

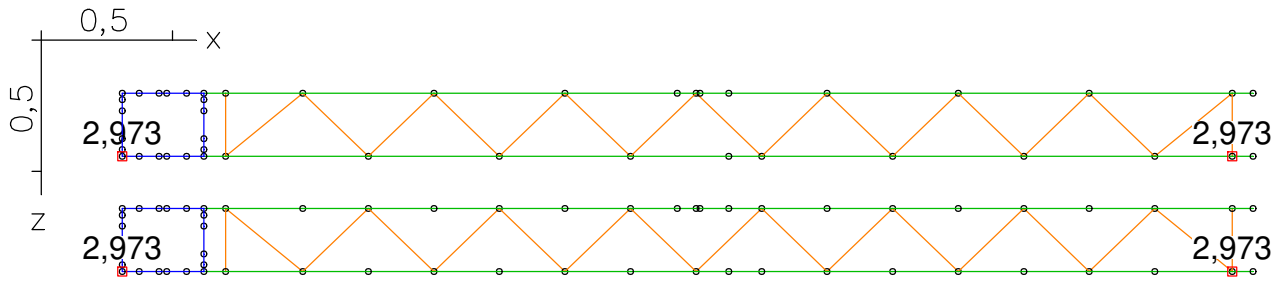

Support reactions Rz max; LFK K100, ULS



5.4 Nachweise

Verifications

[1]	Platte plate	Material Material	Stahl Q235 Steel Q235		
	Spannungsnachweis Stress verification	$\sigma_{Ed} = 195 \text{ N/mm}^2$	(F34)	<	$\sigma_{Rd} = 235 \text{ N/mm}^2$
[2]	Gewinderohr Threaded pipe	Material Material	Stahl Q235 Steel Q235		
	Max. Spannung Max. stress	$\sigma_{Ed} = 143 \text{ N/mm}^2$	(F34)	<	$\sigma_{Rd} = 235 \text{ N/mm}^2$
	Einschraubung Srew-in	$M_{Ed} = 0,29 \text{ kNm} = 29 \text{ kNcm}$	(F34)	<	$M_{Rd} = 156 \text{ kNcm}$
[3]	Gewindehülse Threaded sleeve	Material Material	Stahl Q235 Steel Q235		
	Max. Spannung Max. stress	$\sigma_{Ed} = 41 \text{ N/mm}^2$	(F34)	<	$\sigma_{Rd} = 235 \text{ N/mm}^2$
[4]	Schraube Screw	M12			
	Einschraubtiefe Screw-in depth	mind. 15 mm min. 15 mm			
	Max. Biegemoment Max. bending moment	$M_{Ed} = 0,29 \text{ kNm} = 29 \text{ kNcm}$	(F34)		
	Zugeh. Normalkraft Corresponding normal force	$N_{Ed} = 1,74 \text{ kN}$	(F34)		
	Hebelarm Halbkonus Lever-arm half cone	$e = (40 - 10) / 2 = 15 \text{ mm}$			
	Max. Zugkraft Max. tensile force	$F_{tEd} = 29 / 1,5 + 1,74 = 21 \text{ kN}$		<	$F_{tRd} = 38,8 \text{ kN}$
	Max. Querkraft Max. shear force	$Q_{zEd} = 1,51 \text{ kN}$	(F34)		vernachlässigbar negligible



[5]	Guttröhre Traverse Truss chord	in Wärmeeinflusszone in heat-affected zone	
	Traversentyp F34 Truss type F34	ø50 x 2 mm	
		Bemessungswert des Biegemomentes $M_{Rd} = 42,85$ kNcm Design value of the bending moment	
		Bemessungswert der Normalkraft $N_{Rd} = 35,71$ kNcm Design value of the normal force	
		Maßgebende Schnittgrößen Decisive internal forces	1) $M_{Ed} = 42$ kNcm $N_{Ed} = -1,74$ kNcm
			2) $M_{Ed} = 34$ kNcm $N_{Ed} = 8,11$ kNcm
		Nachweis Verification	1) $42 / 42,85 + (1,74 / 35,71)^{1,3}$ $= 1,0 \leq 1,0$
			2) $34 / 42,85 + (8,11 / 35,71)^{1,3}$ $= 0,94 \leq 1,0$



5.5 Umrechnung der Ergebnisse auf andere Spannweiten

Conversion of the results to other spans

Maximale Auflagerkraft aus Berechnung mit 4 m Traverser + Extender

Maximum reaction from calculation with 4 m Traverser + Extender

$$F_{34} \quad R_{zd} = 2,973 \text{ kN}$$

Eigengewicht

Selfweight

$$F_{34} \quad g = 0,06 \text{ kN/m}$$

Spannweite L = Traversenlänge + 234 mm*

Span L = Truss lengths + 234 mm*

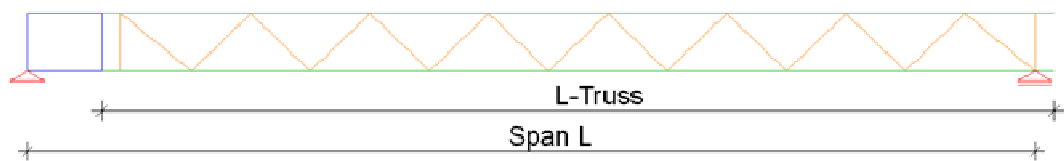

$$*180 + 125 + 6 + 3 - 80 = 234 \text{ mm}$$

Umrechnung der gleichmäßig verteilten Streckenlasten (UDL)

Conversion of uniformly distributed loads

$$F_{34} \quad \text{zul } p = (2,973 \cdot 4 - 1,35 \cdot L \cdot 0,06) / 1,5 / L$$

Umrechnung der mittigen Einzellasten

Conversion of single point loads in the center

$$F_{34} \quad \text{zul } P = (2,973 \cdot 4 - 1,35 \cdot L \cdot 0,06) / 1,5$$

Umrechnung der Lasten in den Drittelpunkten

Conversion of point loads in 1/3 points

$$F_{34} \quad \text{zul } P = (2,973 \cdot 4 - 1,35 \cdot L \cdot 0,06) / 1,5 / 2$$

Umrechnung der Lasten in den Viertelpunkten

Conversion of point loads in 1/4 points

$$F_{34} \quad \text{zul } P = (2,973 \cdot 4 - 1,35 \cdot L \cdot 0,06) / 1,5 / 3$$

Umrechnung der Lasten in den Fünftelpunkten

Conversion of point loads in 1/5 points

$$F_{34} \quad \text{zul } P = (2,973 \cdot 4 - 1,35 \cdot L \cdot 0,06) / 1,5 / 4$$



Bei größeren Spannweiten werden die Beanspruchungen anderer Bauteile der Traversen maßgebend. In den folgenden Tabellen werden die zulässigen Beanspruchungen aus den Statischen Berechnungen der Traversen auf die Spannweiten inklusive der Verlängerung interpoliert.

For larger spans, the stresses on other components of the trusses become decisive. In the following tables, the permissible stresses from the static calculations of the trusses are interpolated to the spans including the extension

Interpolation	F34 (Statik / Report 14905)				
Spannweite L	UDL	in 1/2 Punkt	in 1/3 Punkten	in 1/4 Punkten	in 1/5 Punkten
Span L	UDL	in 1/2 point	in 1/3 points	in 1/4 points	in 1/5 points
4,234	4,64	8,84	6,04	4,76	3,76
5,234	3,20	7,36	5,11	3,96	3,12
6,234	2,26	6,28	4,42	3,34	2,66
7,234	1,67	5,46	3,87	2,88	2,31
8,234	1,28	4,82	3,44	2,53	2,03
9,234	1,01	4,29	3,08	2,24	1,81
10,234	0,81	3,86	2,78	2,01	1,62
11,234	0,67	3,49	2,53	1,81	1,47
12,234	0,55	3,17	2,31	1,64	1,34

Beispiel Example

F34 Traversenlänge 2 m
Truss length 2 m

Zulässige Einzellast in den Fünftelpunkten
Allowable point loads in the 1/5 points
 $g = 0,06 \text{ kN/m}$
 $R_{zd} = 2,973 \text{ kN}$
 $L = 2 + 0,234 = 2,234 \text{ m}$

$zul P = (2,973 \cdot 4 - 1,35 \cdot 2,234 \cdot 0,06) / 1,5 / 4 = 1,95 \text{ kN}$
all. P

zul P aus Statik 14905
all. P from report 14905

nicht angegeben für $L < 4 \text{ m}$
not specified for $L < 4 \text{ m}$



6 ZUSAMMENFASSUNG DER ERGEBNISSE

SUMMARY OF THE RESULTS

6.1 Zulässige Belastung:

Allowable loadings

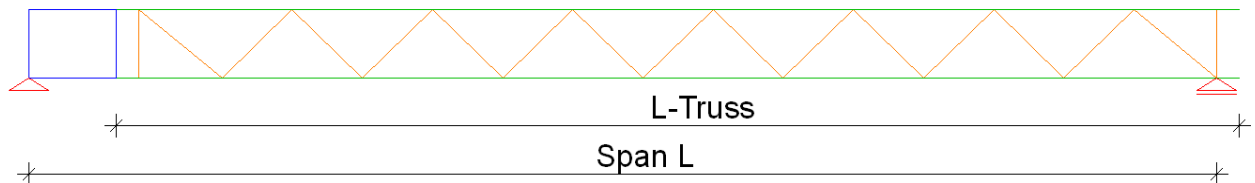

Traverse F34:
Truss F34:

F34						
		Einzellasten / Single point loads				
L, Traverse	Spannweite L	UDL	in 1/2 Punkt	in 1/3 Punkten	in 1/4 Punkten	in 1/5 Punkten
L-Truss	Span L	UDL	in 1/2 point	in 1/3 points	in 1/4 points	in 1/5 points
[m]	[m]	[kN/m]	[kN]	[kN]	[kN]	[kN]
1	1,234	6,37	7,86	3,93	2,62	1,97
2	2,234	3,49	7,81	3,90	2,60	1,95
3	3,234	2,40	7,75	3,88	2,58	1,94
4	4,234	1,82	7,70	3,85	2,57	1,92
5	5,234	1,46	7,36	3,82	2,55	1,91
6	6,234	1,22	6,28	3,80	2,53	1,90
7	7,234	1,04	5,46	3,77	2,51	1,88
8	8,234	0,91	4,82	3,44	2,49	1,87
9	9,234	0,80	4,29	3,08	2,24	1,81
10	10,234	0,72	3,86	2,78	2,01	1,62
11	11,234	0,65	3,49	2,53	1,81	1,47
12	12,234	0,55	3,17	2,31	1,64	1,34

= Werte aus der Statik 14905 sind maßgebend
= values of report 14905 are decisive

Die Tabellenwerte gelten nur für das System eines Einfeldträgers.
The values of the table are only valid for single-span girder.

Alle Lasten sind gleichmäßig auf beide Gurte zu verteilen.
All loads have to be distributed equally to both chords.

Die beiden Lastrichtungen (vertikal und horizontal) werden getrennt voneinander betrachtet! Bei Belastung aus beiden Richtungen sind weitere Nachweise erforderlich!
The two load directions (vertical and horizontal) are considered separately from each other! For loads from both directions further verifications are necessary!

In den angegebenen Werten der Tabelle sind Teilsicherheitsbeiwerte auf der Lastseite nach EN 1990 mit einem $\gamma_F = 1,50$ für Nutzlasten und $\gamma_G = 1,35$ für das Eigengewicht der Traversen berücksichtigt.



The specified values include partial safety coefficients on the loadings side acc. EN 1990 of $\gamma_F = 1.50$ for payloads and $\gamma_G = 1.35$ for selfweight of the truss.

Bei Anwendungsfällen, die auf Grundlage anderer Normen berechnet werden, können die Teilsicherheitsbeiwerte auf der Lastseite angepasst werden (z.B. fliegende Bauten nach EN 13814, $\gamma_F = 1,35$ für Nutzlasten).

For applications which can be calculated on the basis of other codes, the partial safety factors can be adjusted (for example temporary structures acc. EN 13814, $\gamma_F = 1.35$ for payloads).

Bei Anwendung des British Standard (BS) und des ANSI müssen die in den Tabellen aufgeführten zulässigen Belastungen mit dem Faktor 0,85 multipliziert werden.

To use the resulting allowable loads with British Standard (BS) and ANSI, allowable loads listed in tables have to be multiplied by 0.85.